

# OWNER'S MANUAL

## How to operate your EcoWater Systems Water Conditioner/Refiner

**ECOWATER**  
S Y S T E M S®



Your Water. Perfected.

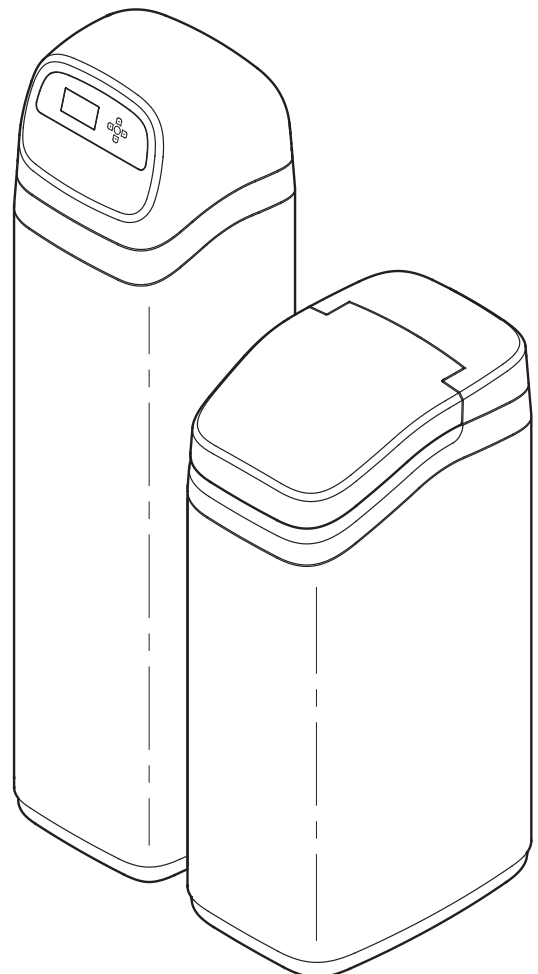
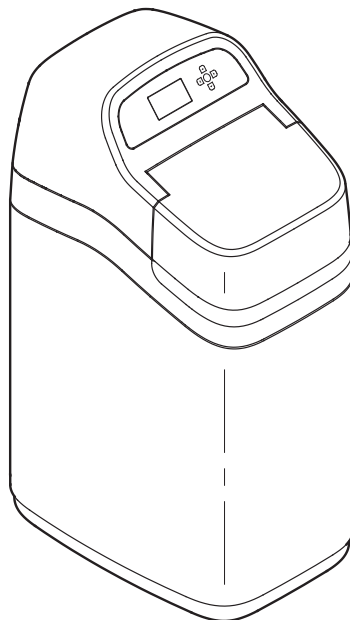
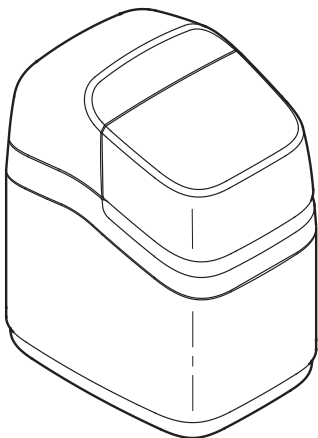
**eVOLUTION**  
Models

**300 Boost**  
**400 Boost**  
**500 Power**  
**Refiner Boost**  
**Refiner Power**

**eVOLUTION** Model  
**600 Power**

**eVOLUTION**  
Models

**100 Compact**  
**200 Compact**



**EcoWater Systems Europe**  
[www.ecowater-europe.com](http://www.ecowater-europe.com)

7365168 (Rev. L 4/1/20)

**TABLE OF CONTENTS**

	<u>Page</u>
Specifications . . . . .	3
Dimensions . . . . .	4-5
Planning Installation . . . . .	6
Unpacking . . . . .	7
Installation . . . . .	7-9
Setup, Wi-Fi Connection & Registration . . . . .	10-13
Conditioner/Refiner Operation . . . . .	14-28
Service Information . . . . .	29-34
Adding Salt . . . . .	29
Troubleshooting Guide . . . . .	32
Schematic . . . . .	35
Repair Parts . . . . .	36-47

**SAFETY GUIDES**

Follow the installation instructions carefully. Failure to install the EcoWater Systems conditioner/refiner properly **voids the warranty**.

Before you begin installation, read this entire manual. Then, obtain all the materials and tools you will need to make the installation.

**Check local plumbing and electrical codes.** The installation must conform to them.

**Use only lead-free solder and flux** for all sweat-solder connections, as required by state and federal codes.

Use care when handling the EcoWater Systems conditioner/refiner. Do not turn upside down, drop, or set on sharp protrusions.

Do not locate the EcoWater Systems conditioner/refiner where freezing temperatures occur. Do not attempt to treat water over 49°C. **Freezing, or hot water damage voids the warranty.**

Avoid installing in direct sunlight. Excessive sun heat may cause distortion or other damage to non-metallic parts.

The EcoWater Systems conditioner/refiner requires a minimum water flow of 11 liters per minute at the inlet. **Maximum allowable inlet water pressure is 8.6 bar.** If daytime pressure is over 5.5 bar, nighttime pressure may exceed the maximum. Use a pressure reducing valve if necessary (Adding a pressure reducing valve may reduce the flow).

The EcoWater Systems conditioner/refiner works on **24V DC** electrical power, supplied by a direct plug-in power supply (included). Be sure to use the included power supply and plug it into a nominal 220-240V, 50/60 Hz household outlet that is in a **dry location only**, grounded and properly protected by an over current device such as a circuit breaker or fuse.

This system is not intended to be used for treating water that is microbiologically unsafe or of unknown quality without adequate disinfection before or after the system.

If conditioner/refiner is being used to reduce barium and/or radium 226 and 228, please verify performance by contacting Legend Technical Services, an independent laboratory, at 1-800-949-8220 for testing treated water supply, or check the water testing section of your local phone directory.

**FCC NOTICE**

**NOTE:** This equipment has been tested and found to comply with the limits for a Class B digital device, pursuant to Part 15 of the **FCC** Rules. These limits are designed to provide reasonable protection against harmful interference in a residential installation. This equipment generates, uses, and can radiate radio frequency energy and, if not installed and used in accordance with the instructions may cause harmful interference to radio communications. However, there is no guarantee that interference will not occur in a particular installation. If this equipment does cause harmful interference to radio or television reception, which can be determined by turning the equipment off and on, the user is encouraged to try to correct the interference by one or more of the following measures:

- Reorient or relocate the receiving antenna.
- Increase the separation between the equipment and receiver.
- Connect the equipment into an outlet on a circuit different from that to which the receiver is connected.
- Consult the dealer or an experienced radio/TV technician for help.

Changes or modifications not expressly approved by EcoWater Systems could void the user's authority to operate the equipment.

This device complies with **Industry Canada** Standard RSS-210. Operation is subject to the following two conditions: (1) this device may not cause interference, and (2) this device must accept any interference, including interference that may cause undesired operation of the device.

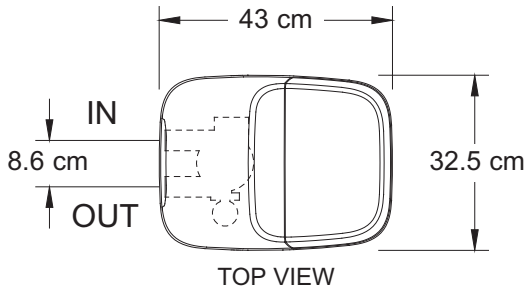
Ce dispositif est conforme avec la norme CNR-210 **d'Industrie Canada**. Le fonctionnement du dispositif est sujet aux deux conditions suivantes: (1) le dispositif ne doit pas causer de brouillage, et (2) le dispositif doit accepter tous brouillages, incluant tous brouillages qui peut nuire au bon fonctionnement du dispositif.



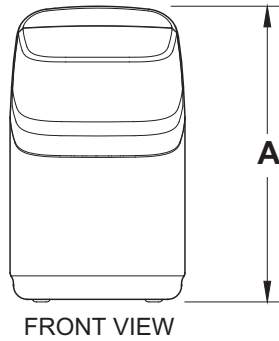
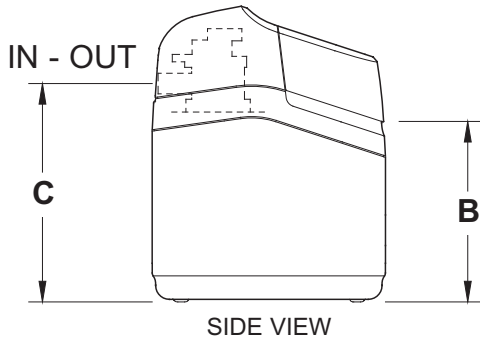
European Directive 2002/96/EC requires all electrical and electronic equipment to be disposed of according to Waste Electrical and Electronic Equipment (WEEE) requirements. This directive or similar laws are in place nationally and can vary from region to region. Please refer to your state and local laws for proper disposal of the equipment.

eVOLUTION Model		100 Compact	200 Compact	300 Boost	400 Boost	500 Power	600 Power	Refiner Boost	Refiner Power
Model Code		S9	S11	S15	S18	S25	S42	R10	R20
Valve Type		3/4" SDV	3/4" SDV	1" SDV	1" SDV	1" DDV	1" DDV	1" SDV	1" DDV
Maximum Capacity per Regeneration	°f·m <sup>3</sup>	48	69	106	147	206	353	56	167
	°dH·m <sup>3</sup>	27	39	59	82	116	198	31	94
	ppm·m <sup>3</sup>	480	690	1060	1470	2060	3530	560	1670
Average Operating Capacity per Regeneration	°f·m <sup>3</sup>	36	48	74	107	148	255	40	122
	°dH·m <sup>3</sup>	20	27	42	60	83	143	22	68
	ppm·m <sup>3</sup>	360	480	740	1070	1480	2550	400	1220
Salt Consumption per Regeneration	kg	0.4 - 1.7	0.5 - 2.7	0.7 - 3.8	0.8 - 4.5	1.2 - 5.5	2.1 - 9.4	0.4 - 1.6	1.0 - 3.4
Water Consumption as % of Water Available between Regenerations, at Max. Capacity and for 30 °f (17 °dH, 300 ppm) Hardness Reduction	%	3	3	2	2	2	2	3	3
Service Flow Rate	lpm	15.1	15.1	22.7	30.3	36.0	37.9	15.1	34.0
	m <sup>3</sup> /h	0.9	0.9	1.4	1.8	2.2	2.3	0.9	2.0
Pressure Drop at Service Flow Rate	bar	0.47	0.73	0.38	0.63	0.50	0.77	0.17	0.45
Intermittent Flow Rate (Maximum Flow)	lpm	23.5	18.2	49.2	43.5	57.2	43.5	53.0	48.5
	m <sup>3</sup> /h	1.4	1.1	3.0	2.6	3.4	2.6	3.2	2.9
Pressure Drop at Intermittent Flow Rate (Maximum Flow)	bar	1.0							
Ion Exchange Resin Amount	liter	8.9	10.4	13.9	17.6	25.0	43.0	10.4	20.5
	kg	7.4	8.6	11.6	14.6	20.8	35.8	8.6	17.1
GAC (Activated Carbon) Amount	liter	–	–	–	–	–	–	5.1	9.3
	kg	–	–	–	–	–	–	2.4	4.4
GAC Capacity for 0.75 ppm Chlorine	m <sup>3</sup>	–	–	–	–	–	–	3000	5500
Gravel Amount	liter	–	–	2.3	2.3	2.8	2.8	2.3	2.8
	kg	–	–	3.7	3.7	4.5	4.5	3.7	4.5
Salt Storage Capacity	kg	18	30	65	110	90	120	65	90
Height	cm	55.5	68.0	88.0	114.0	114.0	145 / 93	88.0	114.0
Width	cm	32.5	32.5	35.5	35.5	35.5	34.5 / 40.5	35.5	35.5
Depth	cm	43.0	43.0	51.0	51.0	51.0	36.0 / 41.5	51.0	51.0
Operating Pressure	bar	1.4 - 8.6							
Operating Temperature	°C	4 - 49							

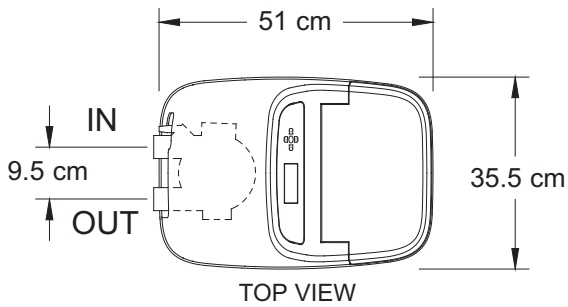
**Cabinet Models**



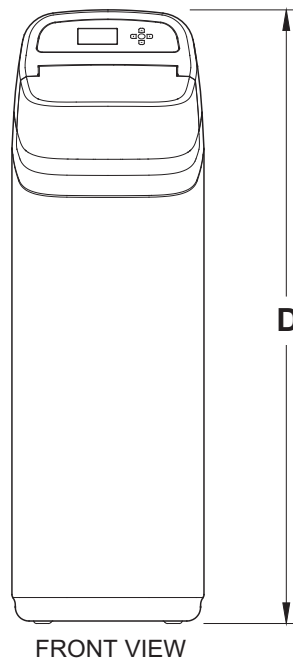
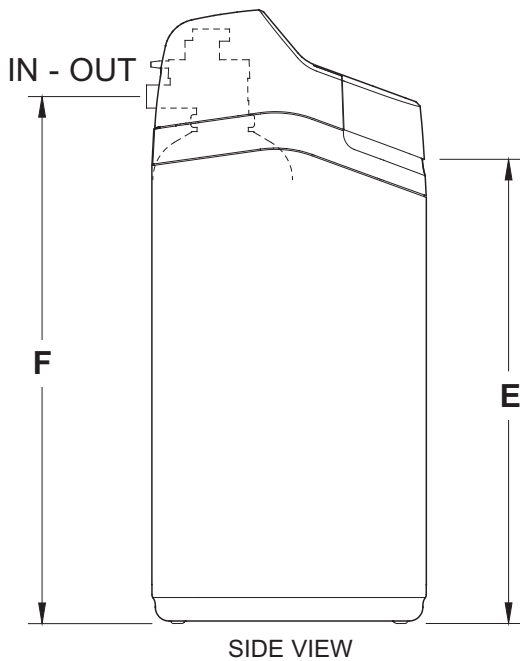
eVOLUTION Model	Nominal Resin Tank Size	Dimension A	Dimension B	Dimension C
100 Compact	9" dia. x 14"	55.5 cm	34.5 cm	41 cm
200 Compact	8" dia. x 19"	68 cm	47 cm	53.5 cm



**FIG. 1**



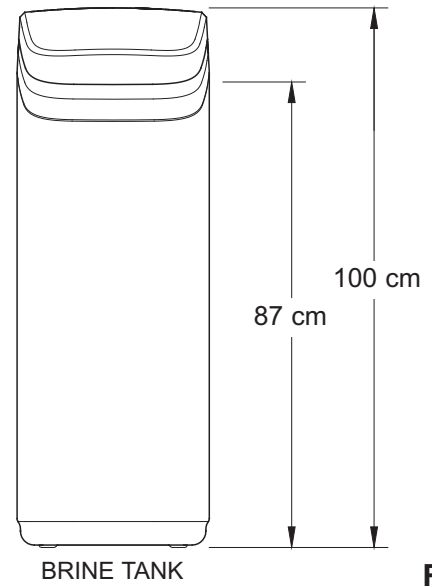
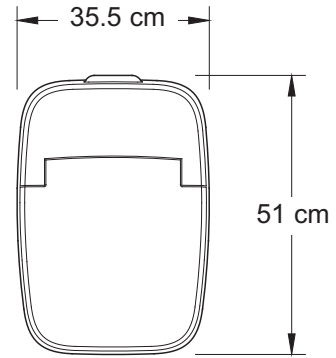
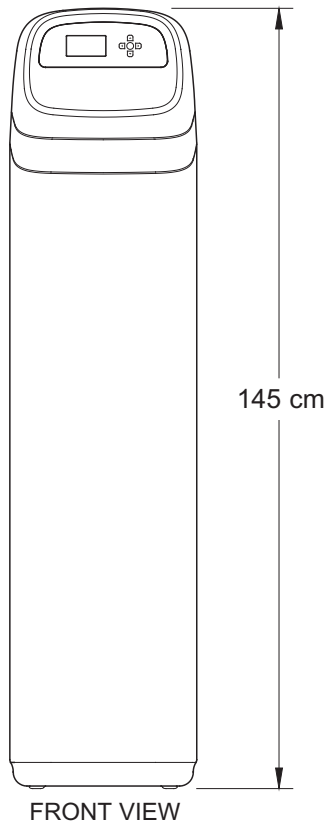
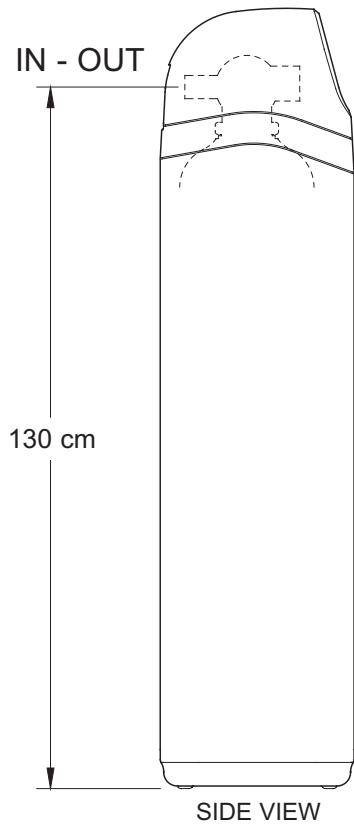
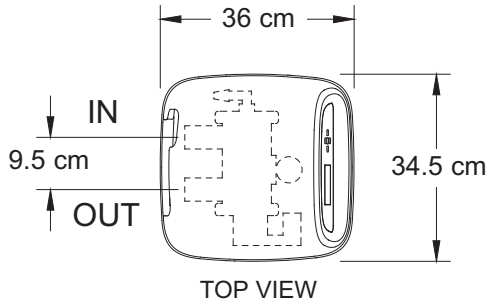
eVOLUTION Model	Nominal Resin Tank Size	Dimension D	Dimension E	Dimension F
300 Boost	8" dia. x 25"	88 cm	61 cm	70.5 cm
Refiner Boost				
400 Boost	8" dia. x 35"	114 cm	87 cm	97 cm
500 Power	10" dia. x 35"	114 cm	87 cm	100 cm
Refiner Power				



**FIG. 2**

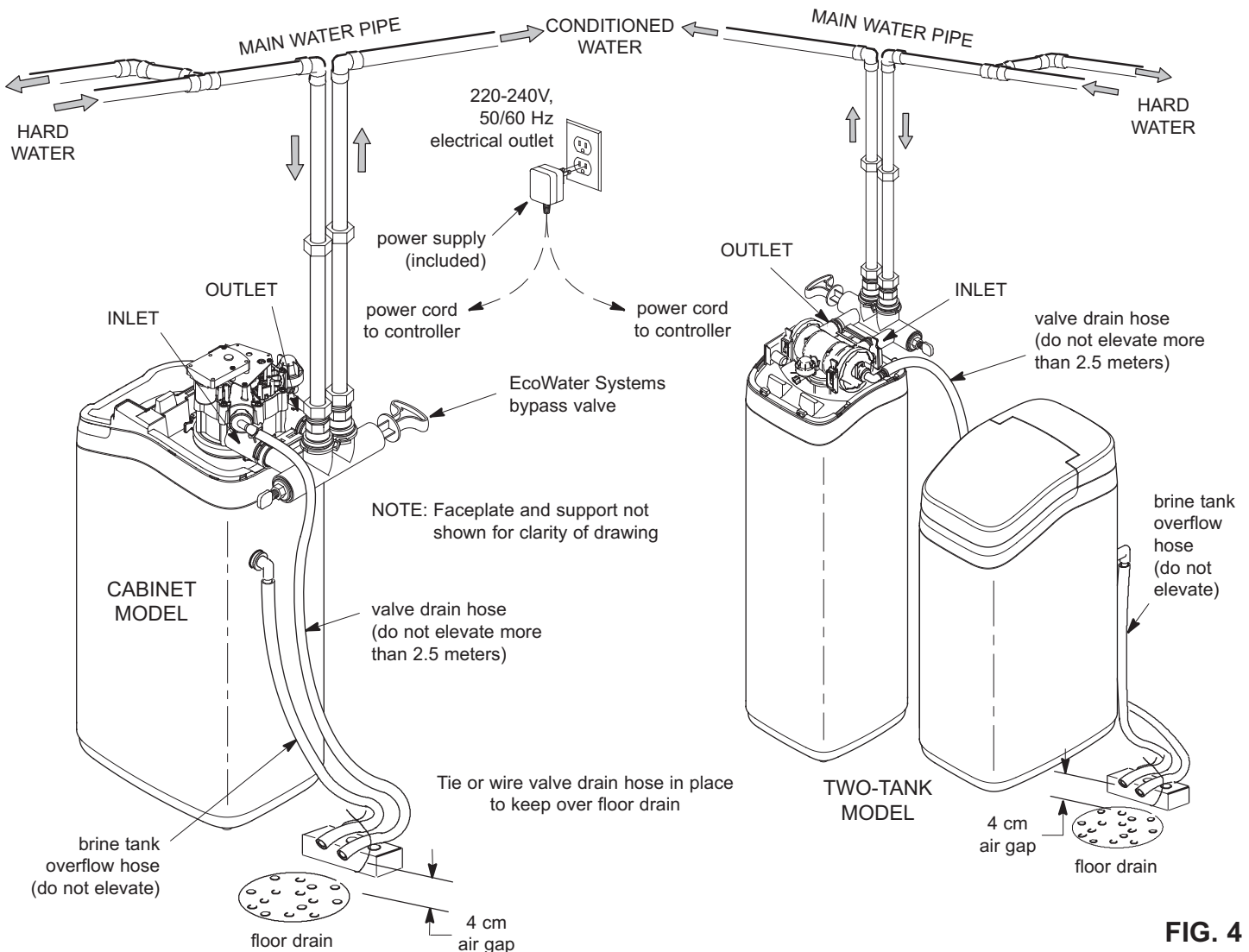
**Two-Tank Model**

eVOLUTION Model	Nominal Resin Tank Size
600 Power	10" dia. x 47"



**FIG. 3**

**TYPICAL INSTALLATION ILLUSTRATIONS**



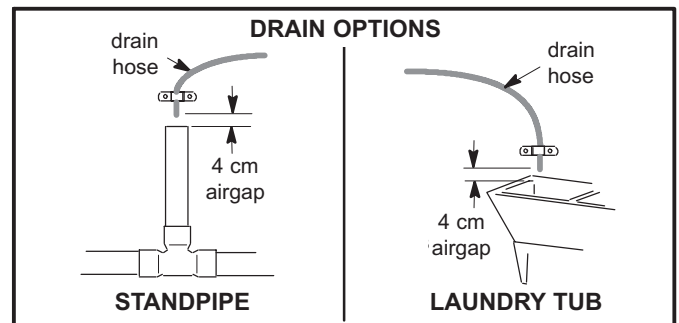
**FIG. 4**

**INLET / OUTLET PLUMBING OPTIONS**

- ALWAYS INSTALL either an EcoWater Systems bypass valve or a 3-valve bypass system. Bypass valves allow you to turn off water to the conditioner/refiner for repairs if needed, but still have water in house pipes.

**OTHER REQUIREMENTS**

- If installing in an outside location, you must take the steps necessary to assure the conditioner/refiner, installation plumbing, wiring, etc., are as well protected from the elements, contamination, vandalism, etc., as when installed indoors.
- A 220-240V, 50/60 Hz, grounded, continuously “live” electrical outlet is needed, in a dry location near the EcoWater Systems conditioner/refiner.



**FIG. 4B**

- A drain is needed for recharge discharge water. A floor drain is preferred, close to the EcoWater Systems conditioner/refiner. A laundry tub, standpipe, etc., are other options (See Figure 4B).

## 1. UNPACKING

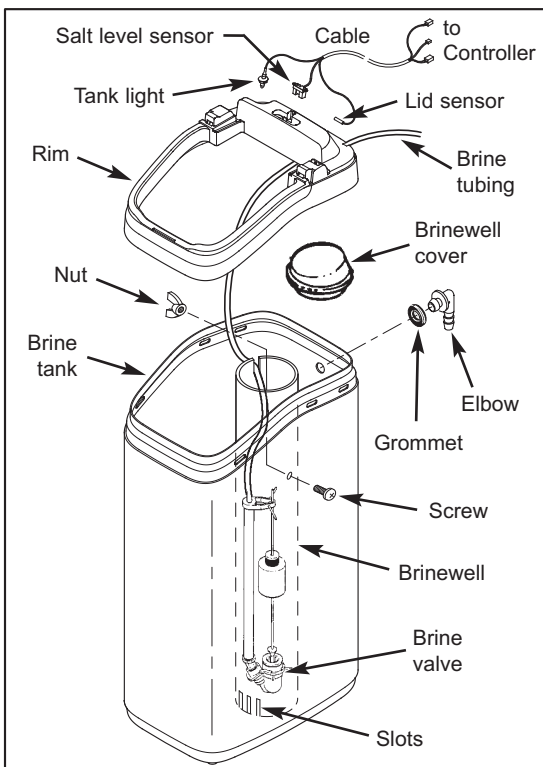
EcoWater Systems eVOLUTION conditioner/refiner models are shipped from the factory in one carton. The carton also includes a bag of small parts needed to assemble and install the unit, plus this manual.

Thoroughly check the EcoWater Systems conditioner/refiner for possible shipping damage and parts loss. Also inspect and note any damage to the shipping carton. Notify the transportation company if damage is present. EcoWater Systems is not responsible for in-transit damages.

Remove and discard (RECYCLE) all packing materials. We suggest you keep the small parts in the bag until you are ready to use them.

## 2. BRINE TANK (on two-tank models)

- Snap the rim into place on the brine tank (See Fig. 5).
- Lower the brinewell, with the slots at the bottom, into the brine tank. Then use the screw and nut from the parts bag to fasten the brinewell in place along the side of the tank.
- Lower the brine valve into the brinewell. Push the tubing into the brinewell top slot (Fig. 5) and route it out through the hole in the back of the rim.
- Install the brinewell cover.
- Take the rubber grommet and hose adaptor elbow from the parts bag. Push grommet into the hole in the back of the brine tank. Then insert the larger diameter end of the elbow through the grommet.



**FIG. 5**

f. Locate the brine tank cable, one end of which is shipped plugged into the back of the electronic controller (PWA). At the loose end of this cable, identify the tank light, salt level sensor and cover sensor. Insert each of these three items into their corresponding slots in the rim, as shown in Figure 5.

g. Route the cable through the clip at the back of the rim.

h. Snap the brine tank cover assembly onto the rim, being careful not to pinch the wires of the brine tank cable.

## 3. INSTALL BYPASS VALVE

a. If installing an **EcoWater Systems Bypass Valve**, put lubricated o-ring seals onto both bypass valve ports (See Figure 6). Carefully slide the bypass valve into the conditioner/refiner valve and install the "C" clips.

b. Connect flexible hoses to the bypass valve (See Figure 6).

**NOTE:** For lubrication, use silicone grease approved for potable water supplies.

## 4. TURN OFF WATER SUPPLY

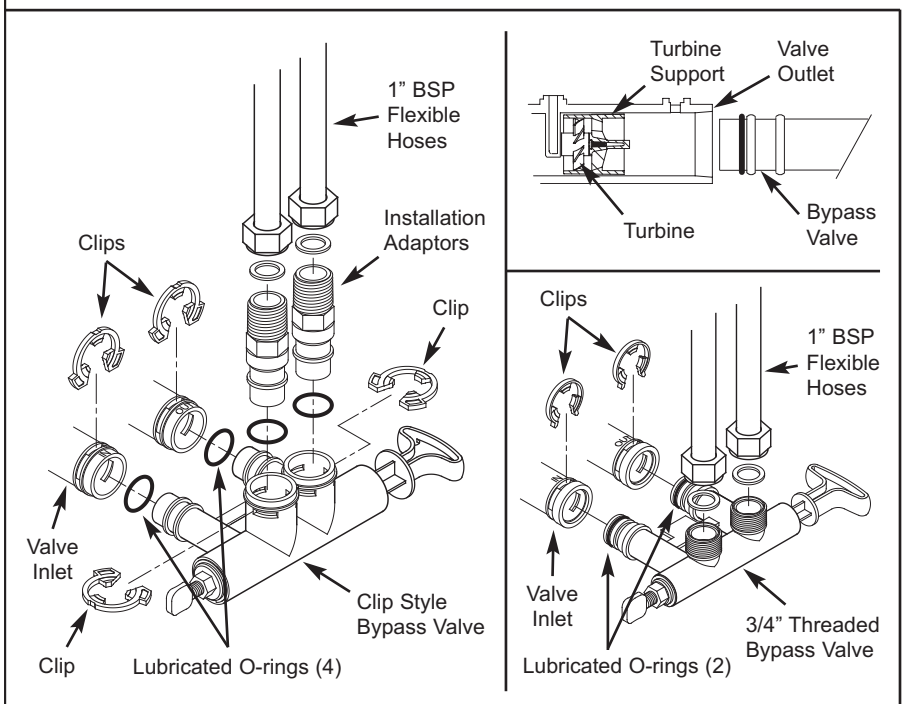
a. Close the main water supply valve near the well pump or water meter.

b. Shut off the electric or fuel supply to the water heater.

c. Open high and low faucets to drain all water from the house pipes.

## 5. INSTALLING THREE-VALVE BYPASS

If installing a 3-valve bypass system, plumb as needed using Figure 9 as a guide. When installing sweat copper, be sure to use lead-free solder and flux, required by federal and state codes. Use pipe joint compound on outside pipe threads.



**FIG. 6**

**6. ASSEMBLE INLET & OUTLET PLUMBING**

Measure, cut, and loosely assemble pipe and fittings from the main water pipe (or from the bypass valves installed in Step 5), to the inlet and outlet copper tubes, installed in Step 3b. Be sure **hard water** supply pipe goes to the **valve inlet side**. Trace the water flow direction to be sure.

**7. CONNECT INLET & OUTLET PLUMBING**

**a. SOLDERED COPPER**

- (1) Thoroughly clean and flux all joints.
- (2) Pull the plastic "C" clips and remove the inlet and outlet tubes from the valve. Remove o-rings from the tubes. **DO NOT solder with tubes in the valve.** Soldering heat will damage the valve.

**NOTE:** If installing a ground as shown in Figure 7A, place ground clamps on copper tubes before soldering (See Step 7a).

- (3) Make all solder connections. Be sure to keep fittings fully together, and pipes square and straight.

**b. THREADED PIPE**

- (1) Apply pipe joint compound to all outside pipe threads.
- (2) Tighten all threaded joints.
- (3) If soldering to the inlet and outlet tubes, observe Step 7a above.

**c. CPVC PLASTIC PIPE**

- (1) Clean, prime and cement all joints, following the manufacturer's instructions supplied with the plastic pipe and fittings.
- (2) If soldering to the inlet and outlet tubes, observe Step 7a above.

**8. COLD WATER PIPE GROUNDING**

The house cold water pipe (metal only) is often used as a ground for the house electrical system. The 3-valve bypass type of installation, shown in Figure 9, will maintain ground continuity. If you use the plastic bypass, continuity is broken.

To restore the ground, do either step **8a** or **8b** following.

- a. Install the EcoWater Systems ground clamp kit (not included) across the inlet and outlet copper pipes (See Figure 7A).
- b. Install a #4 copper wire across the removed section of main water pipe, securely clamping at both ends (See Figure 7B) – parts not included.

**9. INSTALL VALVE DRAIN HOSE**

**NOTE:** See valve drain options on Page 6.

a. Elevating the drain hose may cause back pressure that could reduce the brine draw during recharge. If raising the drain line overhead is required to get to the drain point, measure the inlet water pressure to the conditioner/refiner first. For inlet pressures between 1.4 and 3.4 bar, do not raise higher than 2 meters above the floor. For inlet pressure above 3.4 bar, the drain line may be raised to a maximum height of 3 meters.

b. Connect a length of 1/2" I.D. hose (check codes) to the valve drain elbow, on the controller. Use a hose clamp to hold the hose in place. Route the hose out through the notch in the back of the top cover.

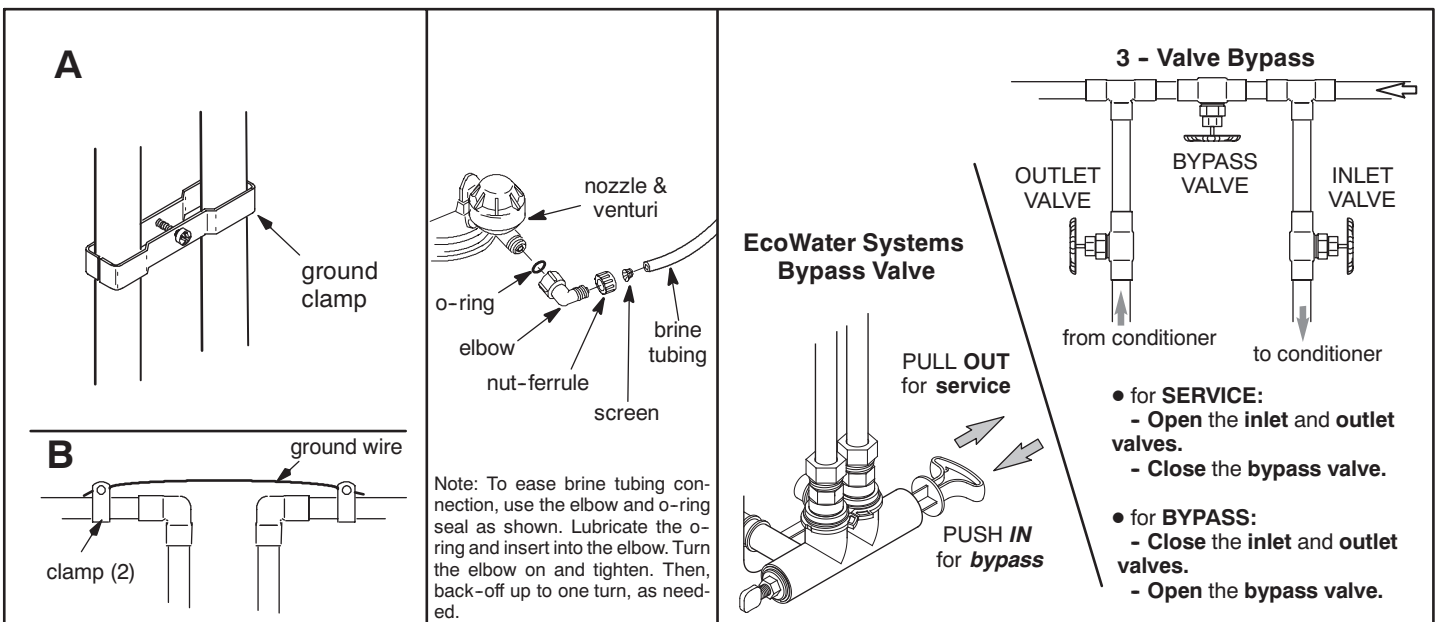
c. Run the hose to the floor drain, and as typically shown in Figure 4, tie or wire the end to a brick or other heavy object. This will prevent "whipping" during recharges. Be sure to provide a 4 cm minimum air gap, to prevent possible sewer water backup.

**10. INSTALL BRINE TANK OVERFLOW HOSE**

a. Connect a length of 1/2" I. D. hose to the brine tank overflow elbow and secure in place with a hose clamp.

b. Run the hose to the floor drain, or other suitable drain point **no higher than the drain fitting** on the tank. If the tank overfills with water, the excess water flows to the drain point.

**11. On Two-tank models,** connect the brine tubing to the nozzle and venturi housing.



**FIG. 7**

**FIG. 8**

**FIG. 9**

## 12. PRESSURE TESTING FOR LEAKS, PROGRAMMING THE CONTROLLER & RINSING THE MEDIA

To prevent excessive air pressure in the EcoWater Systems conditioner/refiner and plumbing system, do the following steps EXACTLY in order:

- a. Fully open two or more **conditioned** cold water faucets nearby the EcoWater Systems conditioner/refiner.
- b. Place the bypass valve(s) in **bypass** position (See Figure 9).
- c. Fully open the main water supply valve. Watch until the flow from the opened faucets becomes steady, with no spurting or air bubbles.
- d. After about three minutes, open a hot water faucet for one minute, or until all air is expelled.
- e. Close all faucets and check your plumbing work for leaks.
- f. Make sure the conditioner/refiner's valve drain hose is hooked up and the open end directed to a floor drain, laundry tub or other suitable type of drain.
- g. Make sure the conditioner/refiner's bypass valve is in the **bypass** position.
- h. Install and plug in the power supply:** Remove the power supply from its packaging and snap the appropriate modular plug (Europe or UK) into place. At the other end of the wires are two small connectors. Plug these into the power wire harness coming from the back of the electronic control board. Plug the power supply into an electrical outlet.
- i. Program the electronic controller:** Follow the Setup Procedure on Pages 10-12 to program the electronic controller with basic operating information, such as time and water hardness. After completing the setup procedure, continue with "j. Start a recharge", below.
- j. Start a recharge:** From the rolling status screens, press the SELECT (○) button to display the **Main menu**. Make sure **Recharge** is highlighted, then press SELECT (○). Press DOWN (▼) to scroll to **Recharge now**, then press SELECT (○) twice. You should hear the valve motor run as the conditioner/refiner begins recharging. Use the RIGHT (▶) button to advance the valve to the **backwash** position.
- k. Once the unit is in backwash, place bypass valve(s) into the service position, as follows:**
  - (1) SINGLE BYPASS VALVE: **Slowly** move the valve stem toward **service** position, pausing several times to allow the unit to pressurize slowly.
  - (2) 3-VALVE BYPASS: Fully close the **bypass** valve and open the **outlet** valve. **Slowly** open the **inlet** valve, pausing several times to allow the unit to pressurize slowly.
- l. Let the conditioner/refiner complete the backwash and fast rinse cycles (takes 10-12 minutes). When the recharge cycle ends, the conditioner/refiner valve returns to the service position.**

## 13. ADD WATER AND SALT TO THE BRINE TANK

- a. Using a pail or garden hose, add about 10 liters of water into the brine tank. DO NOT pour into the brinewell.
  - b. Add salt to the brine tank. It is recommended to fill the brine tank no more than 1/2 full. Level the salt when finished adding. You can use most water conditioner salts, but it must be clean. Recommended nugget, pellet or coarse solar salts have less than 1% impurities.
- NOTE:** See page 29 for additional information on salt.

## 14. SANITIZING THE ECOWATER SYSTEMS CONDITIONER/REFINER

Care is taken at the factory to keep your EcoWater Systems conditioner/refiner clean and sanitary. However, during shipping, storage, installing and operating, bacteria could get into the unit. For this reason, sanitizing as follows is suggested\* when installing.

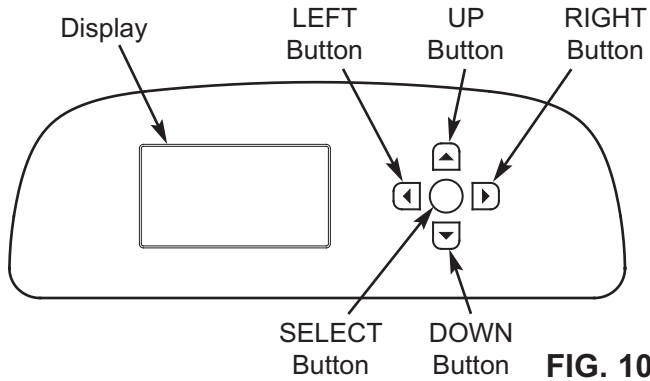
- a. Remove the brinewell cover and pour about 40 ml (2 to 3 tablespoons) of common household bleach into the conditioner/refiner brinewell. Replace the brinewell cover.
- b. Make sure the bypass valve is in the **service** position.
- c. Start a recharge:** From the rolling status screens, press the SELECT (○) button to display the **Main menu**. Make sure **Recharge** is highlighted, then press SELECT (○). Press DOWN (▼) to scroll to **Recharge now**, then press SELECT (○) twice. You should hear the valve motor run as the conditioner/refiner begins recharging. This recharge draws the sanitizing bleach into and through the conditioner/refiner. Any air remaining in the unit is purged to the drain.
- d. After the recharge has completed, fully open a cold water faucet, downstream from the conditioner/refiner, and allow 190 liters of water to pass through the system. This should take at least 20 minutes. Close the faucet.

## 15. RESTART THE WATER HEATER

Turn on the electric or fuel supply to the water heater, and light the pilot, if applies.

**NOTE:** The water heater is filled with hard water and, as hot water is used, it refills with conditioned water. In a few days, the hot water will be fully conditioned. To have fully conditioned hot water immediately, wait until the recharge (Step 14) is complete, then drain the water heater until water runs cold.

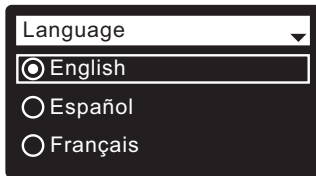
\*Recommended by the Water Quality Association. On some water supplies, the EcoWater Systems unit may need periodic disinfecting.



**FIG. 10**

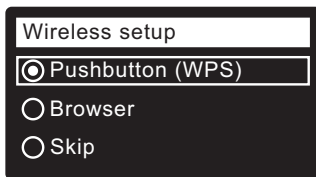
**SETUP PROCEDURE**

When the EcoWater Systems conditioner/refiner is plugged in for the first time, a beep sounds and the display briefly shows a logo, followed by model information. Next, a series of “wizard” screens prompts you to enter basic operating information:



**FIG. 11**

- 1. LANGUAGE** If the desired language already has a dot next to it (See Figure 11), go to Step 2. Otherwise, press the conditioner/refiner’s DOWN (▼) or UP (▲) buttons to scroll to the desired language, then press the SELECT (○) button to choose it.
- Press the SELECT (○) button to advance to the next “wizard” screen.



**FIG. 12**

**NOTE:** Wireless Setup can also be done after the rest of the Setup Procedure (Steps 16-28) has been completed. From the **Main menu**, go down to the **Advanced settings** menu and select **Wireless setup**.

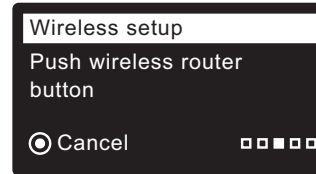
- 3. WIRELESS SETUP** Choose how you will connect the softener to your home’s wireless network:  
**Browser:** You can connect using the browser on your laptop, tablet or phone. Skip to Step 7.

**OR**

**Pushbutton:** If your wireless router has a **WPS** (Wi-Fi Protected Setup) or **Push to Connect** button, you can use this method to connect. Proceed to Step 4.

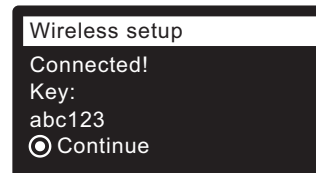
**Pushbutton (WPS) Option**

- Use the SELECT (○) button to choose **Pushbutton (WPS)**. The softener display will change to show “Push wireless router button”.



**FIG. 13**

- Press the WPS or Push to Connect button on your router and wait for a minute or two to see if the display changes again to “Connected” and gives you a key code. If not, you may need to cancel and use the browser option.



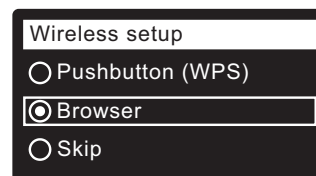
**FIG. 14**

- Once the key code is displayed, write it down. It will be used when you register your system on the EcoWater web site. Proceed to Step 16 on the next page.

**NOTE:** If the “Connected” message shows “-----” (dashes) instead of a key code, it may be that your router is not connected to the internet. Verify that the router’s internet connection works with your laptop or other device.

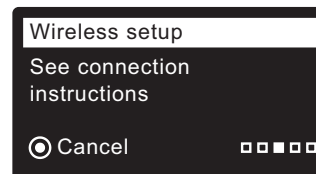
**Browser Option**

- Press the conditioner/refiner’s DOWN (▼) button to scroll to **Browser**.



**FIG. 15**

- Press the SELECT (○) button twice. The softener display will change to show “See connection instructions”.



**FIG. 16**

continued on the next page

continued from the previous page

- On your laptop, tablet or phone, activate the view of wireless networks in range. For example, on a laptop, look for and click on the wireless icon along the lower right edge of the screen. On a phone, you should go into "Settings" and look for "Wi-Fi".



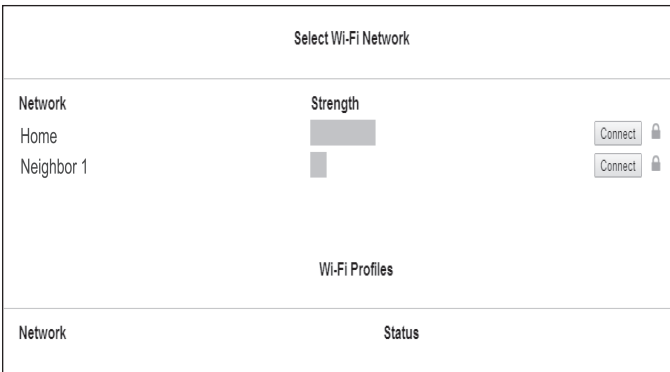
**FIG. 17**

- You should see a network named "H2O-" followed by 12 characters. Select this network to connect your device with it.

- Once your device indicates that it is connected to the H2O network, go to your internet browser (Chrome, Firefox, Internet Explorer, etc.) and type in this URL:

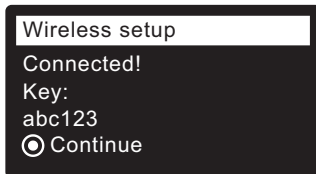
**192.168.0.1**

then click Go or press Enter.



**FIG. 18**

- After a screen like the one shown above appears, select your in-home wireless network and enter the correct password.
- The softener display should change to "Connected" and give you a key code.



**FIG. 19**

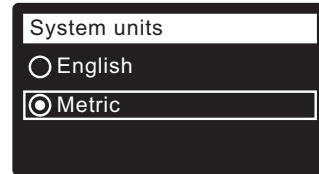
- Once the key code is displayed (it may take a few seconds), write it down. It will be used when you register your system on the EcoWater web site.

**NOTE:** If the "Connected" message shows "-----" (dashes) instead of a key code, it may be that your router is not connected to the internet. Verify that the router's internet connection works with your laptop or other device.

- On your laptop, tablet or phone, go back to the view of networks in range, and make sure that your device is connected back to your local network.

**Finish Setting up the Softener**

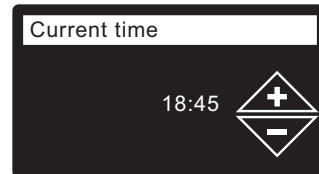
- Once you have connected the Wi-Fi system and written down your key code, press the SELECT (O) button to advance to the next "wizard" screen.



**FIG. 20**

- SYSTEM UNITS** If the desired system already has a dot next to it (See Figure 20), go to Step 18. Otherwise, press the DOWN (▼) or UP (▲) buttons to scroll to the desired system, then press the SELECT (O) button to choose it.

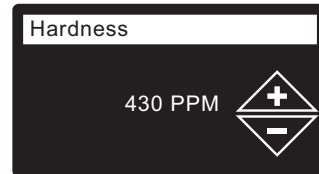
- Press the SELECT (O) button.



**FIG. 21**

- CURRENT TIME** Press the DOWN (▼) or UP (▲) buttons to set the current time (See Figure 21). Hold the button down to rapidly advance. Be sure that AM or PM is correct. If the system units were set to metric in Step 17, the clock will be in 24-hour format.

- Press the SELECT (O) button.

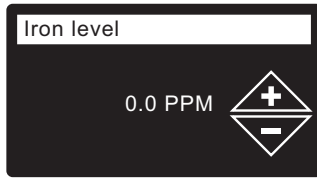


**FIG. 22**

- HARDNESS** Press the UP (▲) or DOWN (▼) buttons to set the value of your water's hardness (See Figure 22).

**NOTE:** Do not increase the hardness setting to compensate for iron in your water. The electronic control compensates automatically after you set the iron level in Step 23, below.

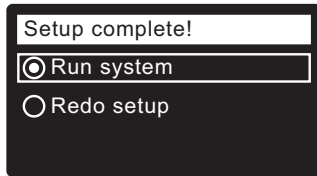
22. Press the SELECT (O) button.



**FIG. 23**

23. **IRON LEVEL** Press the UP (▲) or DOWN (▼) buttons to set the value for iron in your water (See Figure 23).

24. Press the SELECT (O) button. The screen will show “Setup complete!” (See Figure 24).



**FIG. 24**

25. If, at this point, you want to go back and make changes, press the DOWN (▼) button to scroll to **Redo setup**, then press the SELECT (O) button twice to repeat the “wizard” screens.

26. If no changes are desired, make sure **Run system** has a dot next to it (See Figure 24) and press the SELECT (O) button. The unit begins normal operation, described on Page 14.

**HOW TO REGISTER A SYSTEM ON THE ECOWATER WEB SITE AS A DEALER**

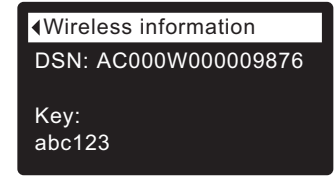
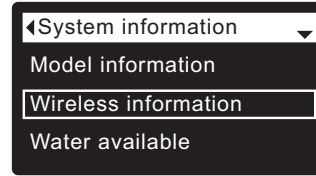
**NOTE:** A dealer registering softeners must log in as a dealer, not as a customer.

27. In your internet browser, type in this URL:

**<http://wifi.ecowater.com>**

28. If you are a dealer, and have an account, log in to your account and go to the next step. If you are a customer, go to Page 13 for instructions to create an account and register.

29. After you’ve logged in to your dealer account, click “Add New Customer System” and then enter the key code that you wrote down earlier. If you wait too long between writing down the key code and registering (an hour or less), the code may change. This is a security feature. Look up the new key code, as described in the following note.



**FIG. 25**

**NOTE:** You can look up the current key code on your softener’s controller. From the **Main menu**, go down to the **System information** menu and select **Wireless information**.

30. After you’ve entered the key code in the **Add System** screen, click the “Connect” button to advance to the **Customer Information** screen.

31. Fill in the customer information (address, e-mail, etc.). When entering a password, either have the customer enter their own, or enter one for them and give it to them. If you intend to share the system, sharing needs to be done from the customer’s account (See “How to Share a System” on the following page). When finished filling in the customer information screen, click the “Save and Continue” button.

**NOTE:** When filling in address information, be sure to select the country before attempting to select a state or province.

32. Fill in the **System Settings** screen and click the “Save Settings” button.

33. Fill in the **Dealer Communication Preferences** screen and click the “Save and Continue” button.

34. The message “Customer System Setup Complete” should appear, along with the customer’s account screen. At this point you can make changes or add another system for this customer. When everything is correct, return to the dealer Home page by clicking the “Home” tab along the top of the page.

35. On the dealer Home page, the new system you set up should appear on the systems list.

**NOTE:** On the dealer Home page, the number of shared systems is displayed below the bar along the top of the screen. You can display only shared systems by clicking “shared with you”, and display all systems again by clicking the “Home” tab. See the following page for instructions on how to share a system.

## HOW TO CREATE AN ACCOUNT AND REGISTER YOUR SYSTEM ON THE ECOWATER WEB SITE AS A CUSTOMER

**NOTE:** A dealer registering softeners must log in as a dealer, not as a customer.

1. In your internet browser, type in this URL:  
**http://wifi.ecowater.com**
  2. If you are a new customer, click on “Create Account” to advance to the **Create Your Account** screen.
  3. Fill in the account information (e-mail, password, language, etc.). Agree to the Terms of Use, and then click the “Create Account” button to advance to the **Customer Information** screen.
  4. Fill in the customer information (name, address, etc.). When finished filling in the customer information screen, click the “Save and Continue” button.
- NOTE:** When filling in address information, be sure to select the country before attempting to select a state or province.
5. Follow the instructions on the **Verify e-mail** screen. You will shortly receive an e-mail confirming that you have created your account. Open this e-mail and click on the link it contains. Your browser will be directed to a **Verification Complete** screen.
  6. Now that you have created your account, you may log in. In the verification screen, click the “logging in” link (or go to **http://wifi.ecowater.com**).
  7. Log in with the e-mail and password that you entered when creating your account.
  8. After you’ve created and logged in to your account, the **Add System** screen will appear. Enter the key code that you wrote down earlier. If you wait too long between writing down the key code and registering (an hour or less), the code may change. This is a security feature. Look up the new key code, as described in the following note.



**FIG. 27**

**NOTE:** You can look up the current key code on your softener’s controller. From the **Main menu**, go down to the **System information** menu and select **Wireless information**.

9. After you’ve entered the key code in the **Add System** screen, click the “Connect” button to advance to the **System Settings** screen.
10. Fill in the **System Settings** screen and click the “Save Settings” button.
11. Fill in the **Communication Preferences** screen and click the “Save and Continue” button.
12. The screen should change to show the Home page for your system, including the softener “dashboard”. Click the “Log Out” tab when you are done.

## VISITING YOUR CUSTOMER ACCOUNT

Any time after your customer account has been created and system registered, you can visit your account to see your softener “dashboard”, change settings, etc. Direct your browser to **http://wifi.ecowater.com** and log in using the e-mail and password that were specified when setting up the account.

## HOW TO SHARE A SYSTEM BETWEEN A DEALER AND CUSTOMER

**NOTE:** A system can only be shared from a customer’s account, not a dealer’s.

Systems can be “shared” between a dealer and customer. If a system is shared, the dealer has full access to the displays and settings for that system on the EcoWater Wi-Fi web site. If a system is not shared, the dealer only has access to the “Dealer Communication Preferences” screen for that system.

Once a customer account has been created by a dealer, a customer can grant a dealer access to their system. Access can only be granted to the dealer who sold that system.

With permission, a dealer (but only the one who sold the system) could also grant it for the customer. To do so, a dealer must log in as a customer rather than as a dealer, using the customer’s e-mail and password (which were entered when the customer account was created).

1. Go to **http://wifi.ecowater.com** and log in (customer’s e-mail and password, not dealer’s).
2. Click on the “Support” tab along the top of the customer Home page.
3. On the **Support** screen, click the “Grant Access” button. It should change to read “Revoke Access”.
4. The system is now shared. Click the “Log Out” tab when you are done.

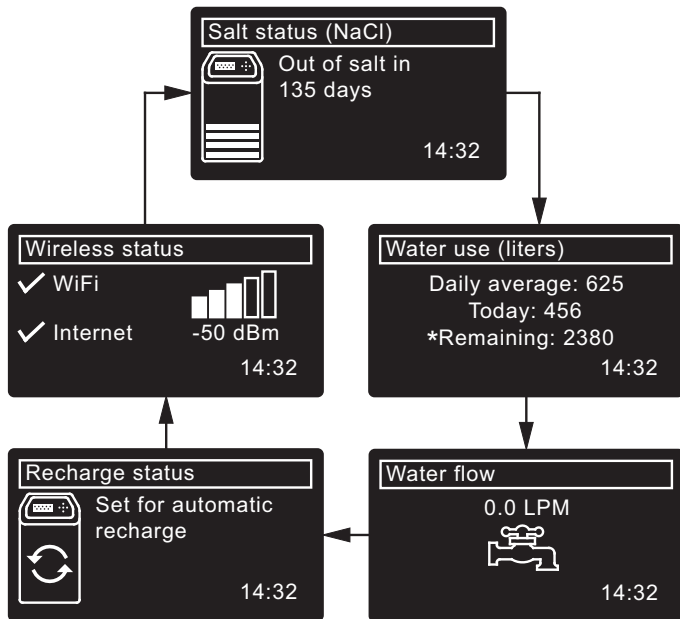
**NORMAL OPERATION**

**CONDITIONER/REFINER STATUS SCREENS**

During normal operation, the EcoWater Systems conditioner/refiner's display shows up to five status screens. Page 20 explains how individual screens can be turned on or off. Each is shown for six seconds, in a rolling sequence (See Figure 28).

In the "Wireless status" screen, the check marks indicate the following:

- ✓ **WiFi** - The softener is connected to a Wi-Fi router.
- ✓ **Internet** - The softener is connected to a Wi-Fi router which is connected to the internet.



\*Water remaining before the next recharge. **FIG. 28**

Pressing the conditioner/refiner's RIGHT (▶) button manually advances to the next screen in the sequence. Pressing the LEFT (◀) button manually returns to the previous status screen. If no buttons are pressed for 30 seconds, the automatic rolling sequence resumes.

**OTHER MESSAGES, ALERTS & REMINDERS**

The conditioner/refiner status screens described in the previous section will not be displayed in a rolling sequence when one of the following items is displayed:

- **Recharge status** (Displayed during recharges, showing valve position and time remaining)
- **Add salt or Out of salt** (See Page 29)
- **Current time** setting screen instead of status screens indicates time has been lost, perhaps after a long power loss. Set the time (See Page 18).
- **Service reminder** (See Page 27)
- **Error detected** (Contact your dealer for service)

**FLASHING DISPLAY**

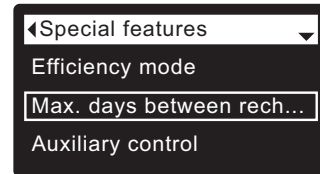
The conditioner/refiner's display will flash on and off when one or more of the following conditions occurs:

- Salt needs to be added
- Time needs to be set (Time has been lost)
- Service is overdue (Service reminder)
- Error condition

The flashing will stop after any key is pressed. However, it will start again at Midnight if the underlying condition (e.g. low salt level) has not been addressed.

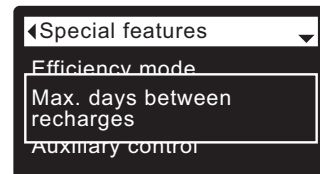
**LONG DISPLAY SCREEN MESSAGES**

Most messages in the conditioner/refiner's display screens are short enough to be shown as a single line. Longer messages will be truncated (See Figure 29 for an example) until you highlight them.



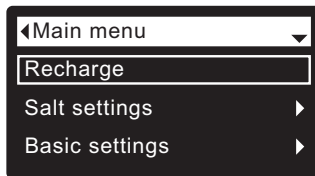
**FIG. 29**

One second after being highlighted, the viewing box expands (See Figure 30) to show the entire message. After three seconds the view resets (Figure 29).



**FIG. 30**

**MAIN MENU**



**FIG. 31**

During normal operation (status screens rolling), press the conditioner/refiner's SELECT (O) button to display the Main menu (See Figure 31). This menu and its subsidiary screens are used to control these operations:

- **Recharge** (See Page 18)
- **Salt settings**
  - **Low salt alarm** (See Page 17)
  - **Salt type** (See Page 17)
- **Basic settings**
  - **Current time** (See Page 18)
  - **Hardness** (See Page 19)
  - **Iron level** (See Page 19)
  - **Recharge time** (See Page 19)
  - **Rolling screens** (See Page 20)
- **User preferences**
  - **Language** (See Page 20)
  - **Time format** (See Page 21)
  - **Volume units** (See Page 21)
  - **Hardness units** (See Page 21)
  - **Weight units** (See Page 21)
- **System information**
  - **Model information** (See Page 22)
  - **Wireless information** (See Page 22)
  - **Water available** (See Page 22)
  - **Daily avg. water used** (See Page 22)
  - **Water used today** (See Page 22)
  - **Total water used** (See Page 22)
  - **Current water flow** (See Page 22)
  - **Days powered up** (See Page 22)
  - **Last recharge** (See Page 22)
  - **Total recharges** (See Page 22)
- **Advanced settings**
  - **Cycle times**
    - **Backwash time**<sup>①</sup> (See Page 24)
    - **Extra backwash time**<sup>②</sup> (See Page 23)
    - **2nd backwash (On/Off)** (See Pages 23-24)
    - **2nd backwash time** (See Pages 23-24)
    - **Fast rinse time**<sup>①</sup> (See Page 24)
    - **Extra fast rinse time**<sup>②</sup> (See Page 23)
  - **Special features**
    - **Efficiency mode** (See Page 25)
    - **Max. days between recharges** (See Page 25)
    - **Auxiliary control** (See Page 26)
    - **Chemical feed volume**<sup>③</sup> (See Page 26)
    - **Chemical feed timer**<sup>③</sup> (See Page 26)
    - **97% feature** (See Page 25)
    - **Service reminder** (See Page 27)
  - **Troubleshooting**
    - **Diagnostics** (See Page 27)
    - **Setup changes** (See Page 28)
    - **SLS calibration** (See Page 28)
  - **Wireless setup** (See Pages 10-12)

① Only on refiners.

② Only on conditioners.

③ Only displayed if Auxiliary control is set to Chemical feed.

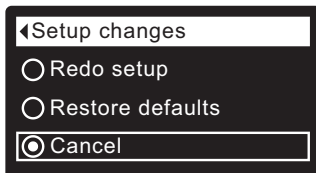
**LOCKOUT FEATURE**

A “lockout” feature is available to prevent user modification of parameters that affect conditioner/refiner performance. The unit is shipped from the factory with the lockout feature off. After programming is complete, the lockout feature can be turned on to prevent changes to the following:

- **Hardness**
- **Iron level**
- **Backwash time**
- **Extra backwash time**
- **Second backwash (On/Off)**
- **Second backwash time**
- **Extra fast rinse time**
- **Fast rinse time**
- **Efficiency mode**
- **Max days between recharges**
- **Auxiliary control**
- **Chemical feed volume**
- **Chemical feed timer**
- **97% feature**
- **Service reminder**
- **Setup changes**
- **SLS calibration point 0**
- **SLS calibration point 1**

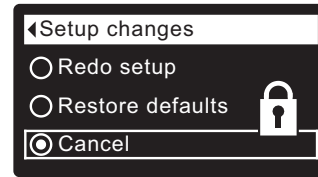
**To turn on the lockout feature:**

1. From any of the rolling status screens, press the SELECT (O) button to display the **Main menu**.
2. Press the DOWN (▼) button to scroll through the menu options until **Advanced settings** is highlighted.
3. Press the SELECT (O) button to display the Advanced settings menu.
4. Press the DOWN (▼) button to scroll through the menu options until **Troubleshooting** is highlighted.
5. Press the SELECT (O) button to display the Troubleshooting menu.
6. Press the DOWN (▼) button to scroll through the menu options until **Setup changes** is highlighted.
7. Press the SELECT (O) button to display the Setup changes menu (See Figure 32).



**FIG. 32**

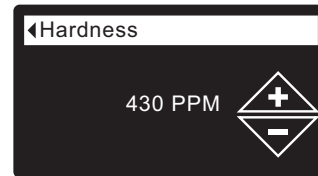
8. Press the RIGHT (▶) button. A flashing padlock icon will appear, as shown in Figure 33.



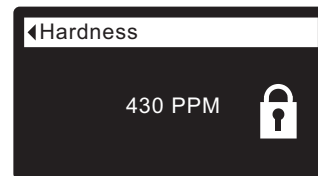
**FIG. 33**

9. Press the SELECT (O) button.
10. Press the LEFT (◀) button three times to return to the rolling status screens.

When the lockout feature is on, the flashing padlock icon will appear in any screen that would normally be used to change a parameter in the list to the left. For example, the **Hardness** screen will look like Figure 35, instead of Figure 34.

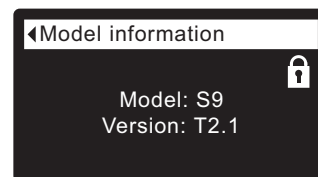


**FIG. 34**



**FIG. 35**

Another indicator that the lockout feature is on is the **Model Information** screen. This screen appears on power-up, and can also be displayed from the System Information menu (See Page 22). If the lockout feature is on, there will be a non-flashing padlock icon in the upper right corner (See Figure 36).



**FIG. 36**

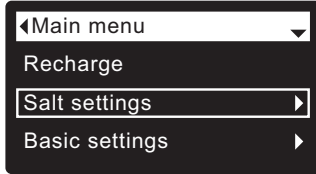
**To turn off the lockout feature:**

- 1-7. Go to the **Setup changes** screen (Figure 33) by following Steps 1-7 at left.
8. Press the RIGHT (▶) button. The flashing padlock icon will disappear, as shown in Figure 32.
9. Press the SELECT (O) button.
10. Press the LEFT (◀) button three times to return to the rolling status screens.

**LOW SALT ALARM**

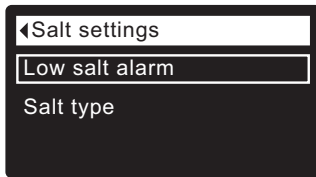
Use this feature to program when the electronic control will display a low salt alarm. The number of days can be customized, or the feature can be turned off. The default is 20 days.

1. From any of the rolling status screens, press the SELECT (O) button to display the **Main menu**.
2. Press the DOWN (▼) button to scroll through the menu options until **Salt settings** is highlighted (See Figure 37).



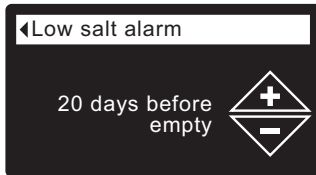
**FIG. 37**

3. Press the SELECT (O) button to display the Salt settings menu (See Figure 38).



**FIG. 38**

4. Make sure **Low salt alarm** is highlighted.
5. Press the SELECT (O) button to display the Low salt alarm screen (See Figure 40).



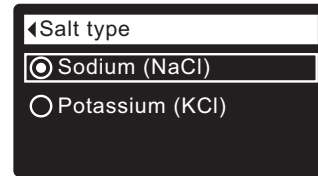
**FIG. 40**

6. Press the DOWN (▼) or UP (▲) buttons to change the number of days. Set the number of days to provide enough time to purchase salt and avoid running into hard water. Setting the number of days below 1 turns the alarm feature off.
7. Press the SELECT (O) button. The display will go back to the Salt settings menu (Figure 38).
8. Press the LEFT (◀) button twice to return to the rolling status screens.

**SETTING SALT TYPE**

Use this feature to program the electronic control with which type of salt is used. The default is NaCl. Selecting KCl increases fill time 25% and brine/slow rinse times 12%.

- 1-3. Go to the **Salt settings** menu by following Steps 1-3 in “Low Salt Alarm” at left.
4. Press the DOWN (▼) button to scroll through the menu options until **Salt type** is highlighted.
5. Press the SELECT (O) button to display the Salt type menu (See Figure 94).



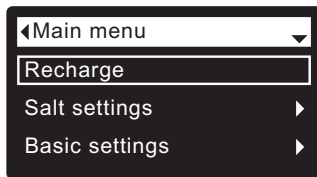
**FIG. 41**

6. If the desired salt type already has a black dot next to it (See Figure 94), go to Step 7. Otherwise, press the conditioner’s DOWN (▼) or UP (▲) buttons to scroll to the other salt type, then press SELECT (O) to choose it.
7. Press the SELECT (O) button. The display will go back to the Salt settings menu.
8. Press the LEFT (◀) button twice to return to the rolling status screens.

## RECHARGING THE CONDITIONER/REFINER

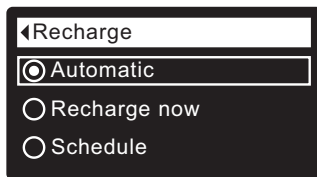
This feature may be used to assure an adequate supply of conditioned water at times of unusually high water use. For example, if you have guests and the “Water available” screen (See Page 22) is at or below 50%, you could deplete conditioned water capacity before the next automatic recharge. Initiating a manual recharge will restore 100% conditioned water capacity after complete.

1. From any of the rolling status screens, press the SELECT (O) button to display the **Main menu**.



**FIG. 42**

2. Make sure **Recharge** is highlighted (See Figure 42).
3. Press the SELECT (O) button to display the Recharge menu (See Figure 43).



**FIG. 43**

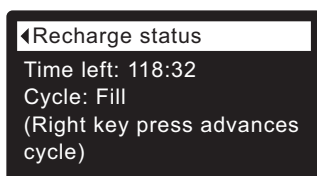
4. If the desired option already has a dot next to it (See Figure 43), go to Step 5. Otherwise, press the DOWN (▼) or UP (▲) buttons to scroll to the desired option, then press SELECT (O) to choose it.

- **Automatic** cancels a manually scheduled recharge (if it has not already begun) and lets the electronic control determine when to recharge next.

- **Recharge now** begins a recharge immediately after the SELECT (O) button is pushed again in Step 5.

- **Schedule** sets a recharge to begin at the preset recharge time (set according to the instructions on Page 19).

5. Press the SELECT (O) button. If **Recharge now** is selected, the display immediately goes to the Recharge status screen (See Figure 44). If **Automatic** or **Schedule** are selected, the display goes back to the Main menu (Figure 42).



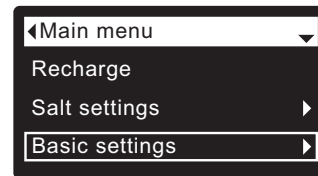
**FIG. 44**

6. Press the LEFT (◀) button (twice from the Recharge status screen) to return to the rolling status screens.

## SETTING THE CURRENT TIME

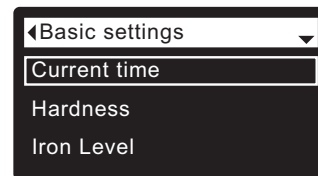
When the conditioner/refiner’s electronic control is first powered up, a “wizard” screen prompts you to set the current time (See Pages 10-12). To change the time at a later date, such as after a long power loss:

1. From any of the rolling status screens, press the SELECT (O) button to display the **Main menu**.
2. Press the DOWN (▼) button to scroll through the menu options until **Basic settings** is highlighted (See Figure 45).



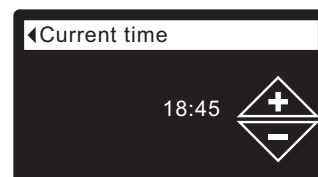
**FIG. 45**

3. Press the SELECT (O) button to display the Basic settings menu (See Figure 46).



**FIG. 46**

4. Make sure **Current time** is highlighted.
5. Press the SELECT (O) button to display the Current time screen (See Figure 47).



**FIG. 47**

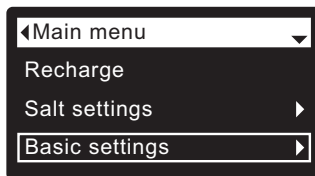
6. Press the UP (▲) or DOWN (▼) buttons to change the time. Hold the button down to rapidly advance. Be sure that AM or PM is correct (unless conditioner/refiner is set for a 24-hour clock).
7. Press the SELECT (O) button. The display will go back to the Basic settings menu (Figure 46).
8. Press the LEFT (◀) button twice to return to the rolling status screens.

**NOTE:** On Wi-Fi connected systems, the current time will be updated and maintained automatically via Wi-Fi.

## SETTING RECHARGE TIME

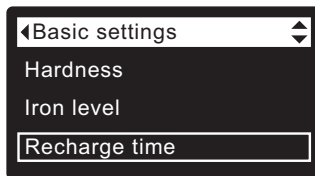
When the conditioner/refiner's electronic control is first powered up, the default time for starting an automatic recharge is 02:00 (2:00 a.m.). This is a good time in most households because water is not being used. To change this time:

1. From any of the rolling status screens, press the SELECT (O) button to display the **Main menu**.
2. Press the DOWN (▼) button to scroll through the menu options until **Basic settings** is highlighted (See Figure 48).



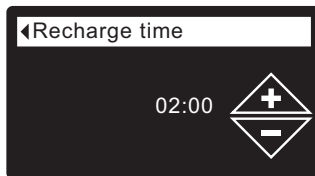
**FIG. 48**

3. Press the SELECT (O) button to display the Basic settings menu (See Figure 49).



**FIG. 49**

4. Press the DOWN (▼) button to scroll through the menu options until **Recharge time** is highlighted.
5. Press the SELECT (O) button to display the Recharge time screen (See Figure 50).



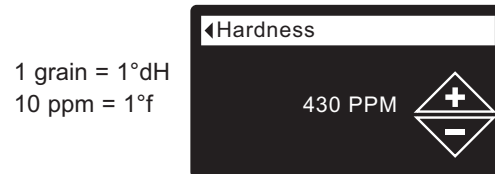
**FIG. 50**

6. Press the UP (▲) or DOWN (▼) buttons to change the recharge time in 1 hour increments. Hold the button down to rapidly advance. Be sure that AM or PM is correct (unless conditioner/refiner is set for a 24-hour clock).
7. Press the SELECT (O) button. The display will go back to the Basic settings menu (Figure 49).
8. Press the LEFT (◀) button twice to return to the rolling status screens.

## SETTING HARDNESS

When the conditioner/refiner's electronic control is first powered up, a "wizard" screen prompts you to enter your water's hardness (See Pages 10-12). To change it:

- 1-3. Go to the **Basic settings** menu by following Steps 1-3 in "Setting Recharge Time" at left.
4. Press the DOWN (▼) button to scroll through the menu options until **Hardness** is highlighted.
5. Press the SELECT (O) button to display the Hardness screen (See Figure 51).



**FIG. 51**

6. Press the UP (▲) or DOWN (▼) buttons to set the value for your water's hardness. Hold the button down to rapidly advance.

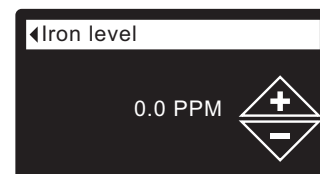
**NOTE:** Do not increase the hardness setting to compensate for iron in your water. The electronic control compensates automatically after you set the iron level, below.

7. Press the SELECT (O) button. The display will go back to the Basic settings menu.
8. Press the LEFT (◀) button twice to return to the rolling status screens.

## SETTING IRON LEVEL

When the conditioner/refiner's electronic control is first powered up, a "wizard" screen prompts you to enter your water's iron level (See Pages 10-12). To change:

- 1-3. Go to the **Basic settings** menu by following Steps 1-3 in "Setting Recharge Time" at left.
4. Press the DOWN (▼) button to scroll through the menu options until **Iron level** is highlighted.
5. Press the SELECT (O) button to display the Iron level screen (See Figure 52).



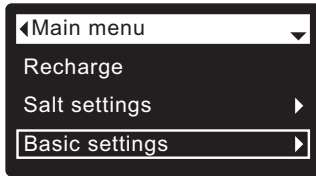
**FIG. 52**

6. Press the UP (▲) or DOWN (▼) buttons to set the value for iron in your water. Hold the button down to rapidly advance.
7. Press the SELECT (O) button. The display will go back to the Basic settings menu.
8. Press the LEFT (◀) button twice to return to the rolling status screens.

**MODIFYING ROLLING SCREENS**

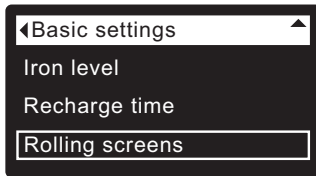
During normal conditioner/refiner operation, four status screens are shown in sequence (See “Conditioner/Refiner Status Screens” on Page 9). When the conditioner/refiner’s electronic control is first powered up, the default is to show all four. You can turn on/off individual screens\*:

1. From any of the rolling status screens, press the SELECT (O) button to display the **Main menu**.
2. Press the DOWN (▼) button to scroll through the menu options until **Basic settings** is highlighted (See Figure 53).



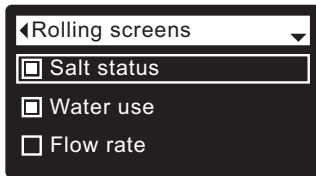
**FIG. 53**

3. Press the SELECT (O) button to display the Basic settings menu (See Figure 54).



**FIG. 54**

4. Press the DOWN (▼) button to scroll through the menu options until **Rolling screens** is highlighted.
5. Press the SELECT (O) button to display the Rolling screens menu (See Figure 55).



**FIG. 55**

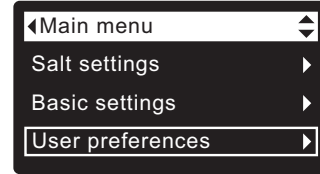
6. Press the DOWN (▼) or UP (▲) buttons to scroll through the list. Items with a black square next to them will be displayed during normal operation.
7. To un-select a screen, make sure its name is highlighted in a box. Then press the SELECT (O) button. The black square will disappear. Pressing SELECT (O) again makes the black square reappear and re-selects the highlighted item. At least one screen must be selected/highlighted.
8. When selections are complete, exit this menu by pressing the LEFT (◀) button. The display will go back to the Basic settings menu (Figure 54).
9. Press the LEFT (◀) button twice to return to the rolling status screens.

\*This does not include service reminders, errors, alerts or Recharge status screens.

**SETTING THE LANGUAGE**

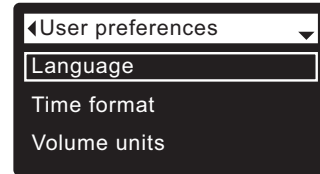
When the conditioner/refiner’s electronic control is first powered up, a “wizard” screen prompts you to set the language (See Pages 10-12). To change the conditioner/refiner’s language:

1. From any of the rolling status screens, press the SELECT (O) button to display the **Main menu**.
2. Press the DOWN (▼) button to scroll through the menu options until **User preferences** is highlighted (See Figure 56).



**FIG. 56**

3. Press the SELECT (O) button to display the User preferences menu (See Figure 57).



**FIG. 57**

4. Make sure **Language** is highlighted.
5. Press the SELECT (O) button to display the Language menu (See Figure 58).



**FIG. 58**

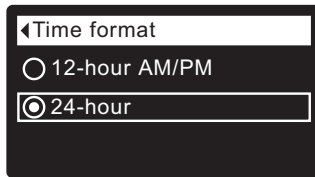
6. If the desired language already has a dot next to it (See Figure 58), go to Step 7. Otherwise, press the DOWN (▼) or UP (▲) buttons to scroll to the desired language, then press SELECT (O) to choose it. The choices are: English, Spanish, French, Italian, German, Dutch, Polish, Russian, Hungarian, Turkish, Lithuanian, Greek, Romanian, Czech, Slovak, Bulgarian, Serbian or Croatian.
7. Press the SELECT (O) button. The display will go back to the User preferences menu (Figure 57).
8. Press the LEFT (◀) button twice to return to the rolling status screens.

**TO SET THE CONDITIONER/REFINER TO ENGLISH IF ANOTHER LANGUAGE IS DISPLAYED:**  
From the rolling status screens, press SELECT (O). Press DOWN (▼) three times, then press SELECT (O) twice. Press UP (▲) to scroll to **English** at the top of the list, then press SELECT (O) twice. Press LEFT (◀) twice to exit all menus.

## SETTING TIME FORMAT

Use this feature to select a 12-hour (AM/PM) or 24-hour clock.

1. From any of the rolling status screens, press the SELECT (O) button to display the **Main menu**.
2. Press the DOWN (▼) button to scroll through the menu options until **User preferences** is highlighted.
3. Press the SELECT (O) button to display the User preferences menu.
4. Press the DOWN (▼) button to scroll through the menu options until **Time format** is highlighted.
5. Press the SELECT (O) button to display the Time format menu (See Figure 59).



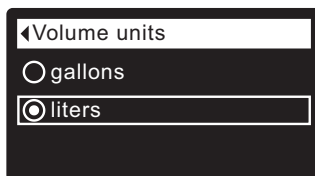
**FIG. 59**

6. If the desired time format already has a dot next to it (See Figure 59), go to Step 7. Otherwise, press the DOWN (▼) or UP (▲) buttons to scroll to the other time format, then press SELECT (O) to choose it.
7. Press the SELECT (O) button. The display will go back to the User preferences menu.
8. Press the LEFT (◀) button twice to return to the rolling status screens.

## SETTING VOLUME UNITS

Use this feature to select gallons or liters as volume units.

- 1-3. Go to the **User preferences** menu by following Steps 1-3 in "Setting Time Format" above.
4. Press the DOWN (▼) button to scroll through the menu options until **Volume units** is highlighted.
5. Press the SELECT (O) button to display the Volume units menu (See Figure 60).



**FIG. 60**

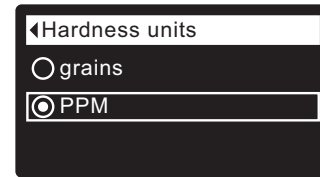
6. If the desired volume unit already has a dot next to it (See Figure 60), go to Step 7. Otherwise, press the DOWN (▼) or UP (▲) buttons to scroll to the other volume unit, then press SELECT (O) to choose it.
7. Press the SELECT (O) button. The display will go back to the User preferences menu.
8. Press the LEFT (◀) button twice to return to the rolling status screens.

## SETTING HARDNESS UNITS

Use this feature to select grains or parts per million (ppm) as hardness units.

1. From any of the rolling status screens, press the SELECT (O) button to display the **Main menu**.
2. Press the DOWN (▼) button to scroll through the menu options until **User preferences** is highlighted.
3. Press the SELECT (O) button to display the User preferences menu.
4. Press the DOWN (▼) button to scroll through the menu options until **Hardness units** is highlighted.
5. Press the SELECT (O) button to display the Hardness units menu (See Figure 61).

1 grain = 1°dH  
10 ppm = 1°f



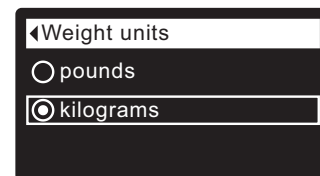
**FIG. 61**

6. If the desired hardness unit already has a dot next to it (See Figure 61), go to Step 7. Otherwise, press the DOWN (▼) or UP (▲) buttons to scroll to the other hardness unit, then press SELECT (O) to choose it.
7. Press the SELECT (O) button. The display will go back to the User preferences menu.
8. Press the LEFT (◀) button twice to return to the rolling status screens.

## SETTING WEIGHT UNITS

Use this feature to select pounds or kilograms as weight units.

- 1-3. Go to the **User preferences** menu by following Steps 1-3 in "Setting Hardness Units" above.
4. Press the DOWN (▼) button to scroll through the menu options until **Weight units** is highlighted.
5. Press the SELECT (O) button to display the Weight units menu (See Figure 62).



**FIG. 62**

6. If the desired weight unit already has a dot next to it (See Figure 62), go to Step 7. Otherwise, press the DOWN (▼) or UP (▲) buttons to scroll to the other weight unit, then press SELECT (O) to choose it.
7. Press the SELECT (O) button. The display will go back to the User preferences menu.
8. Press the LEFT (◀) button twice to return to the rolling status screens.

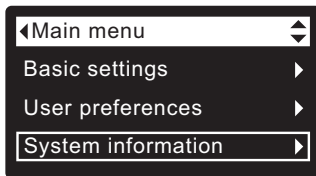
**SYSTEM INFORMATION**

Use these features to look up the following information about the conditioner/refiner and its operations:

- **Model information** (model number and software version)
- **Wireless information**
- **Water available** (conditioned water ready for use)
- **Daily average water used**
- **Water used today**
- **Total water used** (explained in Step 6, below)
- **Current water flow**
- **Days powered up**
- **Last recharge**
- **Total recharges**

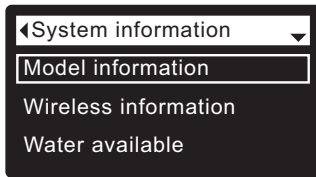
To display one of these screens:

1. From any of the rolling status screens, press the SELECT (O) button to display the **Main menu**.
2. Press the DOWN (▼) button to scroll through the menu options until **System information** is highlighted (See Figure 63).



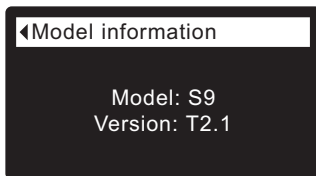
**FIG. 63**

3. Press the SELECT (O) button to display the System information menu (See Figure 64).

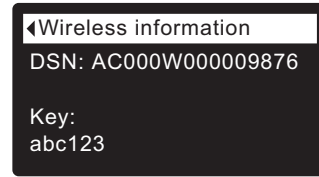


**FIG. 64**

4. Press the DOWN (▼) button to scroll through the menu options until the desired option is highlighted (See list at the top of this column).
5. Press the SELECT (O) button to display the desired information screen (See Figures 65-74).
6. The **Total water used** screen (See Figure 70) shows the volume of water used since it was last reset (it works like the trip odometer in a car). To reset the value to 0, press the RIGHT (▶) button while this screen is displayed.
7. When finished viewing an information screen, press the SELECT (O) button. The display will go back to the System information menu (Figure 64). It will also exit automatically if no buttons are pressed for four minutes.
8. Press the LEFT (◀) button twice to return to the rolling status screens.



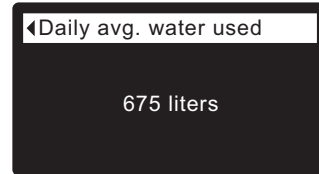
**FIG. 65**



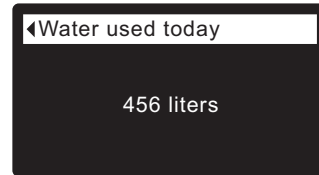
**FIG. 66**



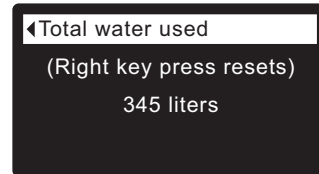
**FIG. 67**



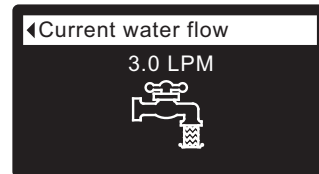
**FIG. 68**



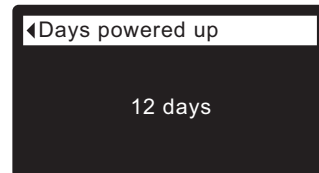
**FIG. 69**



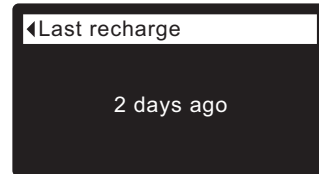
**FIG. 70**



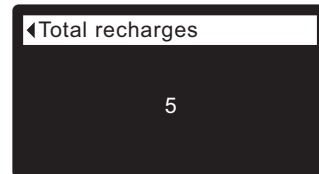
**FIG. 71**



**FIG. 72**



**FIG. 73**



**FIG. 74**

**CYCLE TIMES (Conditioner Models)**

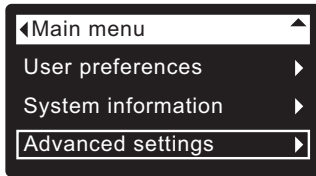
See following page for Refiner cycle times

Use these features to change the following conditioner operations:

- Extra backwash time
- Second backwash (On/Off)
- Second backwash time
- Extra fast rinse time

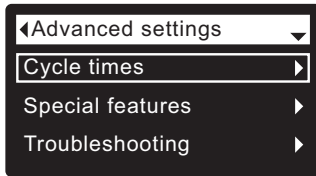
To display these screens:

1. From any of the rolling status screens, press the SELECT (O) button to display the **Main menu**.
2. Press the DOWN (▼) button to scroll through the menu options until **Advanced settings** is highlighted (See Figure 75).



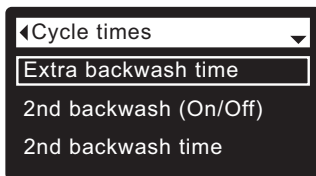
**FIG. 75**

3. Press the SELECT (O) button to display the Advanced settings menu (See Figure 76).



**FIG. 76**

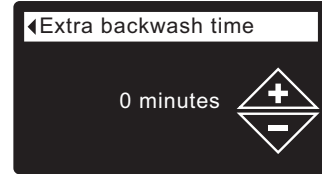
4. Make sure **Cycle times** is highlighted.
5. Press the SELECT (O) button to display the Cycle times menu (See Figure 77).



**FIG. 77**

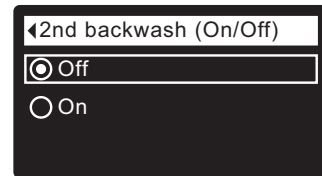
6. Press the DOWN (▼) button to scroll through the menu options until the desired option is highlighted (See list at the top of this column).
7. Press the SELECT (O) button to display the desired cycle time screen (See Figures 78-81).
8. **See the right column on this page for specific instructions on each cycle time screen.**
9. Press the SELECT (O) button. The display will go back to the Cycle times menu (Figure 77).
10. Press the LEFT (◀) button three times to return to the rolling status screens.

**8a. Extra backwash time:** The backwash time during regeneration is determined by the electronic controller. However, if you experience salty tasting water after regeneration, you may want to increase it. Press the UP (▲) button to add minutes, up to 15, of extra backwash time (See Figure 78).



**FIG. 78**

**8b. Second backwash (On/Off):** If the desired option already has a dot next to it (See Figure 79), go to Step 9. Otherwise, press the DOWN (▼) or UP (▲) buttons to scroll to the other option, then press SELECT (O) to choose it. Setting this feature On adds a second backwash and rinse at the beginning of the recharge cycle. Default is Off. Set this feature On if your water supply contains a lot of sediment or iron.



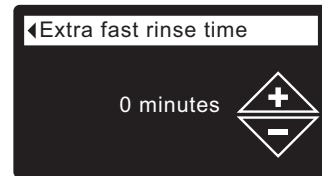
**FIG. 79**

**8c. Second backwash time:** Press the UP (▲) or DOWN (▼) buttons to change the second backwash time. Hold the button down to rapidly advance. The time can be set from 0 to 30 minutes (See Figure 80).



**FIG. 80**

**8d. Extra fast rinse time:** The fast rinse time during regeneration is determined by the electronic controller. However, if you experience salty tasting water after regeneration, you may want to increase it. Press the UP (▲) button to add minutes, up to 15, of extra fast rinse time (See Figure 81).



**FIG. 81**

**CYCLE TIMES (Refiner Models)**

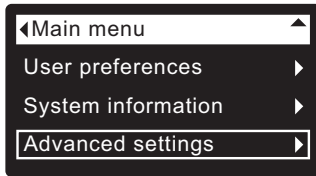
See previous page for Conditioner cycle times

Use these features to change the following conditioner operations:

- Backwash time
- Second backwash (On/Off)
- Second backwash time
- Fast rinse time

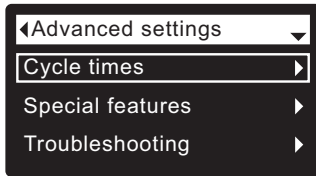
To display these screens:

1. From any of the rolling status screens, press the SELECT (O) button to display the **Main menu**.
2. Press the DOWN (▼) button to scroll through the menu options until **Advanced settings** is highlighted (See Figure 82).



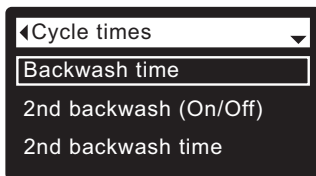
**FIG. 82**

3. Press the SELECT (O) button to display the Advanced settings menu (See Figure 83).



**FIG. 83**

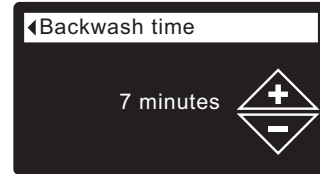
4. Make sure **Cycle times** is highlighted.
5. Press the SELECT (O) button to display the Cycle times menu (See Figure 84).



**FIG. 84**

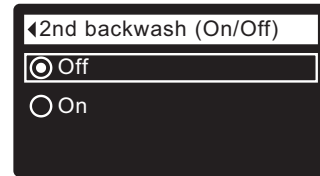
6. Press the DOWN (▼) button to scroll through the menu options until the desired option is highlighted (See list at the top of this column).
7. Press the SELECT (O) button to display the desired cycle time screen (See Figures 85-88).
8. See the right column on this page for specific instructions on each cycle time screen.
9. Press the SELECT (O) button. The display will go back to the Cycle times menu (Figure 84).
10. Press the LEFT (◀) button three times to return to the rolling status screens.

**8a. Backwash time:** Press the UP (▲) or DOWN (▼) buttons to change the backwash time. Hold the button down to rapidly advance. The backwash time can be set from 1 to 30 minutes\* (See Figure 85).



**FIG. 85**

**8b. Second backwash (On/Off):** If the desired option already has a dot next to it (See Figure 86), go to Step 9. Otherwise, press the DOWN (▼) or UP (▲) buttons to scroll to the other option, then press SELECT (O) to choose it. Setting this feature On adds a second backwash and rinse at the beginning of the recharge cycle. Default is Off. Set this feature On if your water supply contains a lot of sediment or iron.



**FIG. 86**

**8c. Second backwash time:** Press the UP (▲) or DOWN (▼) buttons to change the second backwash time. Hold the button down to rapidly advance. The time can be set from 0 to 30 minutes (See Figure 87).



**FIG. 87**

**8d. Fast rinse time:** Press the UP (▲) or DOWN (▼) buttons to change the fast rinse time. Hold the button down to rapidly advance. The fast rinse time can be set from 1 to 30 minutes\* (See Figure 88).



**FIG. 88**

\*Reducing the backwash and fast rinse times below a refiner model's default settings can result in salty water after recharges.

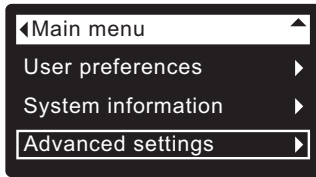
**SPECIAL FEATURES**

Use these features to change the following operations:

- **Efficiency mode**
- **Maximum days between recharges**
- **Auxiliary control** (described on Page 26)
- **Chemical feed volume\*** (described on Page 26)
- **Chemical feed timer\*** (described on Page 26)
- **97% feature**
- **Service reminder** (described on Page 27)

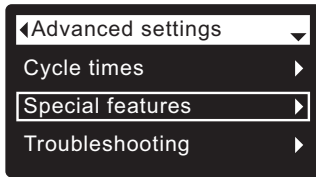
To display one these screens:

1. From any of the rolling status screens, press the SELECT (O) button to display the **Main menu**.
2. Press the DOWN (▼) button to scroll through the menu options until **Advanced settings** is highlighted (See Figure 89).



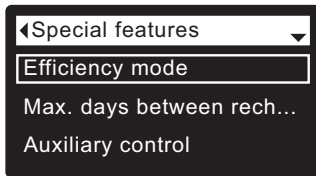
**FIG. 89**

3. Press the SELECT (O) button to display the Advanced settings menu (See Figure 90).



**FIG. 90**

4. Press the DOWN (▼) button to scroll through the menu options until **Special features** is highlighted.
5. Press the SELECT (O) button to display the Special features menu (See Figure 91).



**FIG. 91**

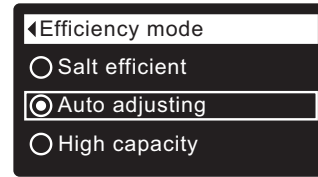
6. Press the DOWN (▼) button to scroll through the menu options until the desired option is highlighted (See list at the top of this column).
7. Press the SELECT (O) button to display the desired special feature screen (See Figures 92-94).
8. **See the right column on this page for specific instructions on each cycle time screen.**
9. Press the SELECT (O) button. The display will go back to the Special features menu (Figure 91).
10. Press the LEFT (◀) button three times to return to the rolling status screens.

**8a. Efficiency mode:** If the desired efficiency mode already has a dot next to it (See Figure 92), go to Step 9. Otherwise, press the DOWN (▼) or UP (▲) buttons to scroll to the desired efficiency mode, then press SELECT (O) to choose it.

● **Salt efficient** limits available salt doses to maintain 4000 grains/lb. of salt efficiency. Units may recharge more frequently.

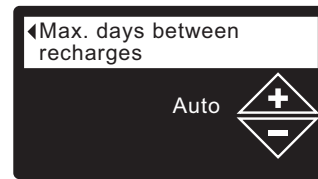
● **Auto adjusting** is the default. It automatically adjusts salt doses to target a 3-4 day interval between recharges. Recommended.

● **High capacity** is for applications where very low “bleed” (less than 1.5 ppm) of hardness can be tolerated. Such applications include water for boilers. This setting will consume higher quantities of salt.



**FIG. 92**

**8b. Maximum days between recharges:** Press the UP (▲) or DOWN (▼) buttons to change the number of days (See Figure 93). The feature can be set from 1 to 15 days. Setting the number of days below 1 turns the feature off and defaults to automatic control of recharging.



**FIG. 93**

**8c. 97% feature:** If the desired option already has a dot next to it (See Figure 94, go to Step 9. Otherwise, press the DOWN (▼) or UP (▲) buttons to scroll to the other option, then press SELECT (O) to choose it. If this feature is On, the conditioner/refiner will automatically recharge when 97% of capacity is used, at any time of day. Default is Off.



**FIG. 94**

\*Only displayed if Auxiliary control is set to Chemical feed.

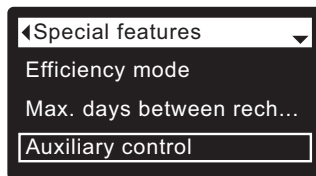
**AUXILIARY CONTROL**

The electronic control has an auxiliary output which can control external devices in a water treatment system. The signal is 24V DC, current draw 500 mA maximum. The Auxiliary Output terminals are located on the electronic control board (See Schematic on Page 35).

For more details on the use of auxiliary controlled equipment in water treatment systems, consult the EcoWater Systems "Problem Water Guide."

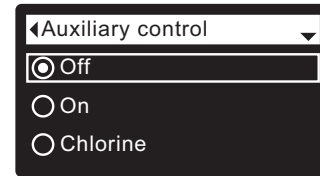
To select an auxiliary control mode:

1. From any of the rolling status screens, press the SELECT (O) button to display the **Main menu**.
2. Press the DOWN (▼) button to scroll through the menu options until **Advanced settings** is highlighted.
3. Press the SELECT (O) button to display the Advanced settings menu.
4. Press the DOWN (▼) button to scroll through the menu options until **Special features** is highlighted.
5. Press the SELECT (O) button to display the Special features menu (See Figure 95).



**FIG. 95**

6. Press the DOWN (▼) button to scroll through the menu options until **Auxiliary control** is highlighted.
7. Press the SELECT (O) button to display the Auxiliary control menu (See Figure 96).
8. If the desired option already has a dot next to it (See Figure 96), go to Step 9. Otherwise, press the DOWN (▼) or UP (▲) buttons to scroll to the desired option, then press SELECT (O) to choose it.
  - **Off** is the default. The 24V DC output is always off.
  - **On**: The 24V DC output is always on.
  - **Chlorine** can be used to drive a chlorine generator, which produces chlorine, as brine water passes through it, to sanitize the resin during recharges.
  - **Bypass**: Turns 24V DC on during the entire regeneration cycle (when the conditioner's valve is in bypass and hard water is going to the house).
  - **Chemical feed**: Can be used to run a chemical feed pump. If chosen, the chemical feed volume and timer must be set, as detailed at right)
  - **Water use**: Turns 24V DC on when the conditioner's turbine indicates water flow. Could drive an air pump for iron or sulfur oxidation.
  - **Fast Rinse**: Turns 24V DC on during the fast rinse portion of the regeneration cycle.
9. Press the SELECT (O) button. The display will go back to the Special features menu (Figure 95).
10. Press the LEFT (◀) button three times to return to the rolling status screens.



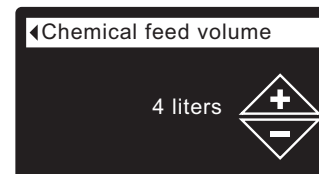
**FIG. 96**

**CHEMICAL FEED**

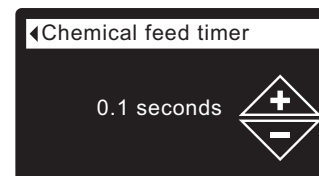
If the auxiliary control mode has been set to **Chemical feed**, as described in the previous section, two additional lines (**Chemical feed volume** and **Chemical feed timer**) will appear on the Special features menu.

To set these values:

1. From any of the rolling status screens, press the SELECT (O) button to display the **Main menu**.
2. Press the DOWN (▼) button to scroll through the menu options until **Advanced settings** is highlighted.
3. Press the SELECT (O) button to display the Advanced settings menu.
4. Press the DOWN (▼) button to scroll through the menu options until **Special features** is highlighted.
5. Press the SELECT (O) button to display the Special features menu (See Figure 95).
6. Press the DOWN (▼) button to scroll through the menu options until **Chemical feed volume** or **Chemical feed timer** is highlighted.
7. Press the SELECT (O) button to display the Chemical feed volume or Chemical feed timer menu (See Figures 97 & 98).



**FIG. 97**

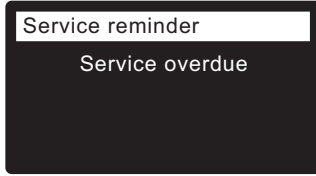


**FIG. 98**

8. Press the UP (▲) or DOWN (▼) buttons to change the value. Hold the button down to rapidly advance.
  - **Chemical feed volume** is the amount of water which will pass through the conditioner/refiner between each activation of the chemical feed equipment.
  - **Chemical feed timer** is how long the output to the chemical feed equipment is energized each time it is activated.
9. Press the SELECT (O) button. The display will go back to the Special features menu (Figure 95).
10. Press the LEFT (◀) button three times to return to the rolling status screens.

**SERVICE REMINDER (set / reset)**

Use this feature to program the number of months (up to 24) before a “Service overdue” message will appear instead of the rolling status screens (See Figure 99).

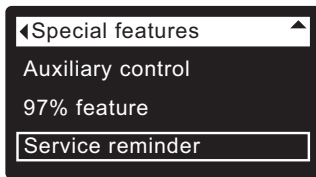


**FIG. 99**

This message also appears on the remote. This will be a reminder to call your dealer for service. Once programmed, this feature displays the number of months and days left until the service reminder.

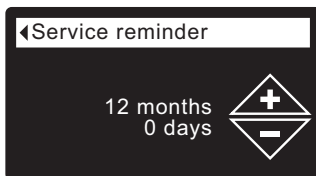
Once the “Service overdue” message has appeared, dealers performing service clear it by setting the number of months until the next service reminder. Set or reset the service reminder as follows:

1. From any of the rolling status screens, press the SELECT (O) button to display the **Main menu**.
2. Press the DOWN (▼) button to scroll through the menu options until **Advanced settings** is highlighted.
3. Press the SELECT (O) button to display the Advanced settings menu.
4. Press the DOWN (▼) button to scroll through the menu options until **Special features** is highlighted.
5. Press the SELECT (O) button to display the Special features menu (See Figure 100).



**FIG. 100**

6. Press the DOWN (▼) button to scroll through the menu options until **Service reminder** is highlighted.
7. Press the SELECT (O) button to display the Service reminder screen (See Figure 101).



**FIG. 101**

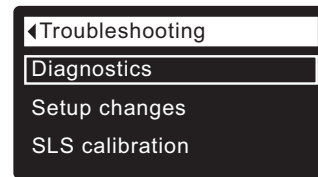
8. Press the UP (▲) or DOWN (▼) buttons to set the number of months until the service reminder appears. Repeatedly pressing the DOWN (▼) button until the display reads “Off” turns this feature off and zeros the number of months and days.
9. Press the SELECT (O) button. The display will go back to the Special features menu (Figure 100).
10. Press the LEFT (◀) button three times to return to the rolling status screens.

**DIAGNOSTICS**

This feature allows a service technician to check the operating state of individual components in the conditioner/refiner (e.g. valve position) to troubleshoot problems. **If an error code is displayed in place of the rolling status screens, call your dealer for service.**

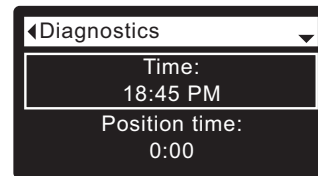
To view the Diagnostics screen:

1. If an error code is displayed, skip Steps 2-7 and go directly to Step 8.
2. To display the Diagnostics screen from any of the rolling status screens (when an error code is not displayed), press the SELECT (O) button to display the **Main menu**.
3. Press the DOWN (▼) button to scroll through the menu options until **Advanced settings** is highlighted.
4. Press the SELECT (O) button to display the Advanced settings menu.
5. Press the DOWN (▼) button to scroll through the menu options until **Troubleshooting** is highlighted.
6. Press the SELECT (O) button to display the Troubleshooting menu (See Figure 102).



**FIG. 102**

7. Make sure **Diagnostics** is highlighted.
8. Press the SELECT (O) button to display the Diagnostics screen (See Figure 103).



**FIG. 103**

9. Press the DOWN (▼) or UP (▲) buttons to scroll through the list. The following items are displayed:
  - **Time** (current)
  - **Position time** (counts down the time remaining in the current valve position)
  - **Current position** (of the valve: service, fill, brine, backwash, fast rinse or moving)
  - **Requested position** (of the valve)
  - **Motor state** (on or off)
  - **Valve position switch** (open or closed)
  - **Turbine count** (if changing, indicates water flow)
  - **Salt level sensor** (distance reading of sensor)
  - **Tank light switch** (open or closed)
  - **RF module** (detected or not)
  - **Error code** (call for service if a number is displayed)

continued on the next page

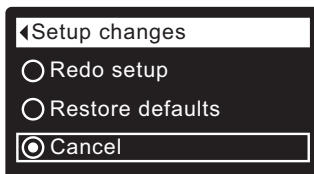
continued from the previous page

10. When finished viewing the Diagnostics screen, press the SELECT (O) button. The display will go back to the Troubleshooting menu.
11. Press the LEFT (◀) button three times to return to the rolling status screens (or error code screen if an error condition exists).

## SETUP CHANGES

This feature allows a service technician to repeat the setup procedure (See Pages 10-12) or restore the conditioner/refiner's default operating values.

1. From any of the rolling status screens, press the SELECT (O) button to display the **Main menu**.
2. Press the DOWN (▼) button to scroll through the menu options until **Advanced settings** is highlighted.
3. Press the SELECT (O) button to display the Advanced settings menu.
4. Press the DOWN (▼) button to scroll through the menu options until **Troubleshooting** is highlighted.
5. Press the SELECT (O) button to display the Troubleshooting menu (See Figure 102).
6. Press the DOWN (▼) button to scroll through the menu options until **Setup changes** is highlighted.
7. Press the SELECT (O) button to display the Setup changes menu (See Figure 104).



**FIG. 104**

8. If the desired option already has a dot next to it (See Figure 104), go to Step 9. Otherwise, press the DOWN (▼) or UP (▲) buttons to scroll to the desired option, then press SELECT (O) to choose it.
  - **Redo setup** allows you to select a different model code (intended to be used for upgrades or retrofits of existing conditioner/refiner). Model codes are listed on Page 3.
  - **Restore defaults** will reset all customizable settings to their default values and take you through the “wizard” screen setup procedure (See Pages 10-12).
  - **Cancel** will return to the Troubleshooting menu (Figure 102).
9. Press the SELECT (O) button.

## SLS CALIBRATION

This feature is used by a service technician replacing a salt level sensor. A replacement salt level sensor is shipped from the factory with numerical values for two calibration points, and these values must be entered into the controller. Instructions for this procedure are supplied with the replacement salt level sensor.

**NOTE:** Do not change the numerical values of the SLS calibration points unless installing a replacement salt level sensor.

## ADDING SALT

If the conditioner/refiner uses all the salt before more is added, hard water will result. EcoWater eVOLUTION series models have automatic salt level sensing. Your Wi-Fi account can also be used to monitor salt. The conditioner/refiner salt status screen has an optional display of the estimated number of days until salt is depleted (“Out of salt in X days”). The conditioner/refiner can also be programmed to display a Low Salt Alarm a certain number of days before salt is estimated to run out (See Page 17).

Be sure that the brinewell cover is on when adding salt.

**NOTE:** In humid areas it is best to keep the salt level less than half full and add salt more often.

**RECOMMENDED SALT:** Cube, pellet, coarse solar, etc., water conditioner salt is recommended. This type of salt is high purity evaporated crystals, sometimes formed and pressed into briquets. It has less than 1% insoluble (not dissolvable in water) impurities. Clean, high grade rock salts are acceptable, but may require frequent brine tank cleaning to remove the “sludge” residue (insolubles) collecting at the bottom of the tank.

**POTASSIUM CHLORIDE:** If you choose potassium chloride (KCl) salt as a regenerant:

- 1) Make sure “Salt type” on the electronic control is set to “KCl”, as shown on Page 17.
- 2) Place only one bag of potassium chloride (KCl) into your conditioner/refiner at a time. The salt storage tank should never contain more than 25 kg of KCl.

**SALT NOT RECOMMENDED:** Rock salt high in impurities, block, granulated, table, ice melting, or ice cream making salts, etc., are not recommended.

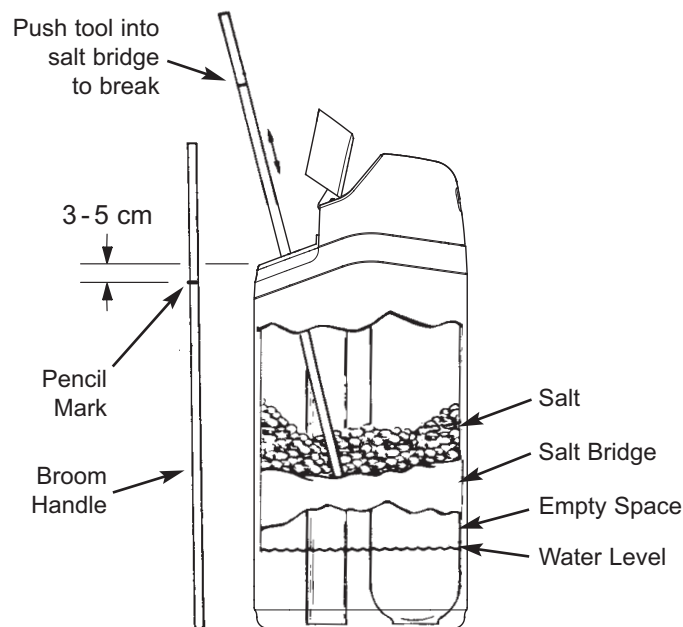
**SALT WITH IRON REMOVING ADDITIVE:** Some salts have an additive to help a water conditioner/refiner handle iron in the water supply. Although this may help keep the resin bed clean, it may also release corrosive fumes that will weaken and shorten the life of some EcoWater Systems conditioner/refiner electronic parts. Iron Out salt is safe to use on two-tank models.

## BREAKING A SALT BRIDGE

Sometimes a hard crust or salt “bridge” forms in the brine tank. This is usually caused by high humidity or the wrong kind of salt. When the salt bridges, an empty space forms between the water and the salt. Then salt will not dissolve in the water to make brine. Without brine, the resin bed is not recharged and hard water will result.

If the storage tank is full of salt, it is difficult to tell whether there is a salt bridge. A bridge may be underneath loose salt. The following is the best way to check for a salt bridge:

Salt should be loose all the way to the bottom of the tank. Hold a broom handle, or like tool, up to the conditioner/refiner, as shown in Figure 105. Make a pencil mark on the handle 3 - 5 cm below the top of the rim. Then, carefully push it straight down into the salt. If a hard object is felt before the pencil mark is even with the top, it is most likely a salt bridge. Carefully push into the bridge in several places to break it. **Do not try to break the salt bridge by pounding on the outside of the salt tank. You may damage the tank.**



**FIG. 105**

**CLEANING THE NOZZLE & VENTURI**

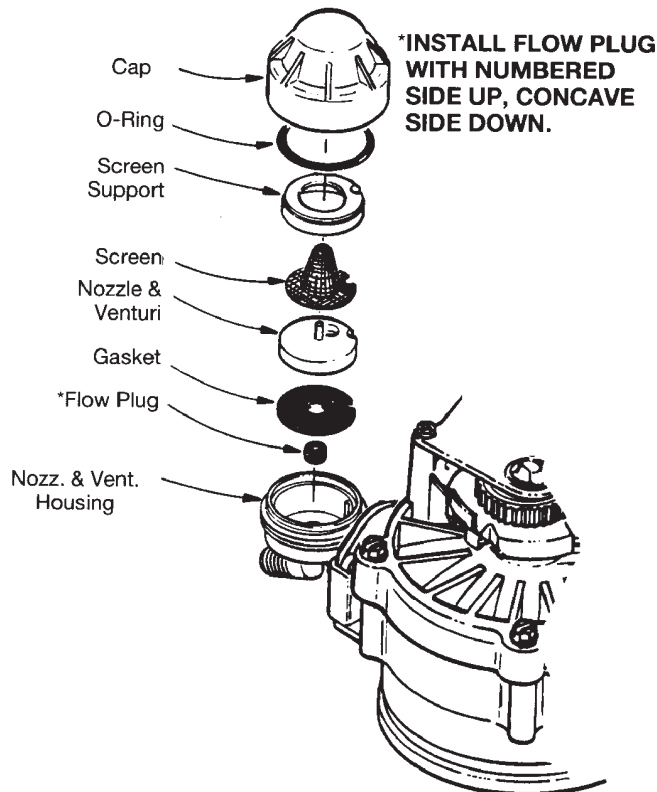
A clean nozzle & venturi (See Figure 106) is necessary for the EcoWater Systems conditioner/refiner to work properly. This small unit creates the suction to move brine from the brine tank into the resin tank. If it should become plugged with dirt, silt, sand, etc., the EcoWater Systems conditioner/refiner will not work and hard water will result.

To get access to the nozzle & venturi, remove the conditioner/refiner's top cover. Put the bypass valve(s) into the bypass position. Be sure the conditioner/refiner is in the service cycle (no water pressure at the nozzle & venturi). Then, holding the nozzle & venturi housing with one hand, turn the cap to remove it. Do not lose the o-ring seal. Lift out the screen support and screen. Then, remove the nozzle & venturi. Wash the parts in warm, soapy water and rinse in fresh water. If needed, use a small brush to remove iron or dirt. Be careful not to scratch, misshape, etc., surfaces of the nozzle & venturi. Also, check and clean the gasket and flow plug(s) if dirty.

Carefully replace all parts in the correct order. Lubricate the o-ring seal with silicone grease and put in place. Install and tighten the cap, by hand only. Do not overtighten, which could break the cap or housing. Put the bypass valve(s) into service (conditioned water) position.

**RESIN BED CLEANING**

If the water supply contains clear water iron, regular resin bed cleaning is needed to keep the bed from coating with iron. Use resin bed cleaner, available from EcoWater Systems, following directions on the container. Clean the resin every six months, or more often if iron appears in the conditioned water supply.



**FIG. 106**

## RELIEVING WATER PRESSURE WITH THE BYPASS VALVE(S)

**CAUTION:** Always relieve water pressure in the EcoWater Systems conditioner/refiner, as described below, before removing parts from the valve or resin tank.

### DE-PRESSURIZE

1. Put bypass valve(s) into **Bypass** position.
2. Place conditioner/refiner valve in **Fill** position by performing Steps 1 & 7 of Manual Advance Recharge procedure on Page 34.

### PRESSURIZE

1. Put bypass valve(s) into **Service** position.
2. Return conditioner/refiner valve to **Service** position by performing Steps 10-16 of Manual Advance Recharge procedure on Page 34.

## ALTERNATE METHODS:

### 3-VALVE BYPASS (See Figure 107)

#### DE-PRESSURIZE

1. Close the INLET valve.
2. Open HOT and COLD conditioned water house faucets.
3. Close the OUTLET valve and open the BYPASS valve.
4. Close all house faucets.

#### PRESSURIZE

1. Open HOT and COLD house faucets.
2. Close the BYPASS valve and open the OUTLET valve.
3. **Slowly**, open the INLET valve.
4. Close all house faucets.

## ECOWATER SYSTEMS BYPASS VALVE

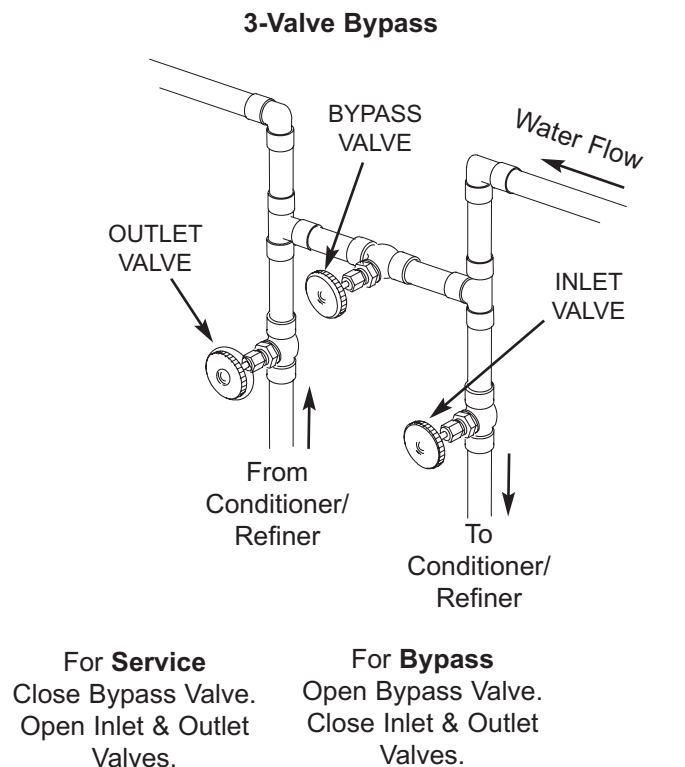
(See Figure 108)

#### DE-PRESSURIZE

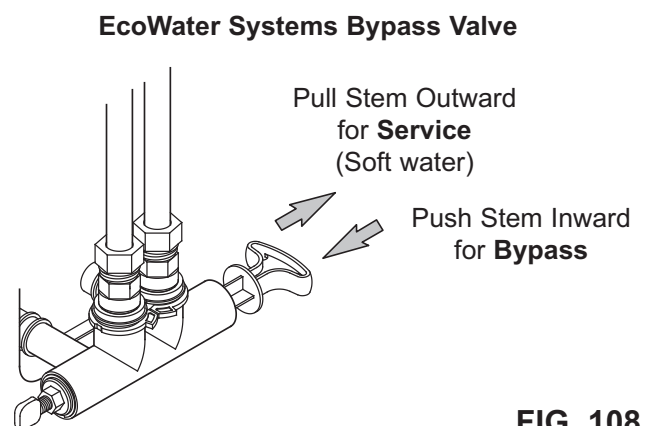
1. Close the house main water supply valve.
2. Open HOT and COLD conditioned water house faucets.
3. Push the bypass valve handle to **Bypass** position.
4. Optional: For hard water bypass to house faucets, reopen the main water supply valve.

#### PRESSURIZE

1. Open main water supply valve if it is closed.
2. Open HOT and COLD house faucets.
3. Pull the bypass valve handle to **Service** position.
4. Close all house faucets.




**FIG. 107**



**FIG. 108**

**TROUBLESHOOTING GUIDE**

<b>PROBLEM</b>	<b>CAUSE</b>	<b>CORRECTION</b>
<b>Cannot set some conditioner/refiner parameters and display shows a padlock icon:</b> 	Lockout feature is on.	Turn off the lockout feature (See Page 16).
<b>No soft water</b>	No salt in the storage tank.	Add salt (See Page 29) and then initiate a "Recharge now," as shown on Page 18.
	Salt is "bridged."	Break salt bridge (See Page 29) and then initiate a "Recharge now," as shown on Page 18.
	If display is blank, power supply may be unplugged at wall outlet, power cable leads may be disconnected from the electronic control board, fuse may be blown, circuit breaker may be popped, or power supply may be plugged into a switched outlet which is "off."	Check for power loss due to any of these and correct. When power is restored, if the display shows the "Current Time" setting screen (Figure 47 on Page 18), it means time was lost during the outage. Set the current time. Other settings such as hardness are retained in memory during a power loss.
	Bypass valve(s) in bypass position.	Referring to Figure 9 on Page 8, place bypass valve(s) in service position.
	Dirty, plugged or damaged nozzle & venturi.	Take apart, clean and inspect the nozzle & venturi assembly, as shown on Page 30.
	Valve drain hose plugged or restricted.	Drain hose must not have any kinks, sharp bends, or be raised too high above the conditioner/refiner (See Page 8).
<b>Water hard sometimes</b>	Bypassed hard water being used during recharge, due to current time or recharge time settings being incorrect.	Check the current time displayed. If not correct, refer to "Set Current Time" on Page 18. Check the recharge time, as described on Page 19.
	Hardness number setting is too low.	Referring to "Setting Hardness" on Page 19, check the current hardness setting and increase if needed.
	Hot water being used when conditioner/refiner is recharging.	Avoid using hot water during recharges, because water heater refills with hard water.
	Increase in actual hardness of water supply.	Have unsoftened water sample tested. Referring to Page 19, check the current hardness setting and increase if needed.
	Turbine is not turning freely.	Check turbine, as described on Page 33.
<b>Motor stalled or clicking</b>	Motor malfunction or internal valve fault causing high torque on motor.	Contact your dealer for service.
<b>Error code E1, E3 or E4 displayed.</b>	Fault in wiring harness, connections to position switch, switch, valve or motor.	Contact your dealer for service.
<b>Error code E5 displayed.</b>	Electronic control malfunction.	Contact your dealer for service.

**TROUBLESHOOTING - INITIAL CHECKS**

**Always make these initial checks first:**

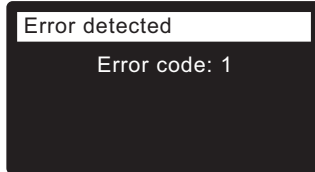
1. Is display blank? Check power source.
2. Is Error code displayed? If so, go to "Automatic Electronic Diagnostics" on the next page.
3. Is correct time displayed? If not, recharges occur at the wrong time. Set current time (See Page 18.)
4. Is there salt in the brine tank? If not, refill.
5. Is salt "bridged" (See Page 29)?
6. Are plumbing bypass valve(s) in service position (See Figure 9 on Page 8)?
7. Are inlet and outlet pipes connected to the EcoWater conditioner/refiner inlet and outlet respectively?

8. Is valve drain hose free of kinks and sharp bends, and not elevated over 2 meters above the floor.
9. Is the brine tube connected (See Fig. 8 on Page 8)?
10. Check the hardness setting (See "Setting Hardness on Page 19). Be sure it is correct for the household's water supply. Perform a hardness test on a raw water sample to compare with the setting.
11. Perform a hardness test on a conditioned water sample to determine whether a problem exists.

If no problem is found after making the initial checks, proceed to "Troubleshooting - Manual Diagnostics" and "Manual Advance Recharge Check" on the next two pages.

## AUTOMATIC ELECTRONIC DIAGNOSTICS

This conditioner/refiner has a self-diagnostic function for the electrical system (except for input power and/or water meter). The controller monitors electronic components and circuits for correct operation. If a malfunction occurs, an **Error code** is displayed (See Figure 109).



**FIG. 109**

The troubleshooting chart on the previous page shows the error codes that could appear, and the possible malfunctions for these codes.

When an error code appears in the display, pressing SELECT (O) will display the **Diagnostics** screen (See Page 28), so a service technician can further isolate the problem.

## REMOVING ERROR CODE

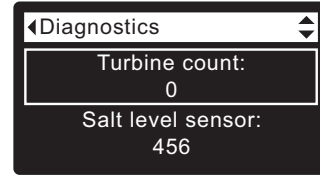
1. Unplug power supply from electrical outlet.
2. Correct problem.
3. Plug power supply back in.
4. Wait for eight minutes while controller operates valve through an entire cycle. The error code will return if the problem was not corrected.

## TROUBLESHOOTING - MANUAL DIAGNOSTICS

1. Display the **Diagnostics** screen, following the procedure on Page 28.
2. Press the DOWN (▼) or UP (▲) buttons to scroll through the list. The following items are displayed:
  - **Time** (current)
  - **Position time** (counts down the time remaining in the current valve position)
  - **Current position** (of the valve: service, fill, brine, backwash, fast rinse or moving) See “Manual Advance Recharge Check” on next page for position verification.
  - **Requested position** (of the valve)
  - **Motor state** (on or off)
  - **Valve position switch** (open or closed)
  - **Turbine count** (indicates water flow) See following section for turbine diagnostics.
  - **Salt level sensor** (distance reading of sensor)
  - **Tank light switch** (open or closed)
  - **RF module** (detected or not)
  - **Error code**

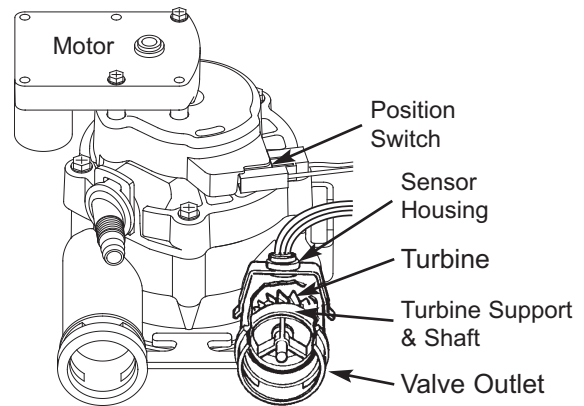
## CHECKING THE TURBINE

1. Display the **Diagnostics** screen, following the procedure on Page 28.
2. Press the DOWN (▼) button to scroll through the list until **Turbine Count** is displayed (See Figure 110).



**FIG. 110**

3. A steady display of “0” (zero) indicates no water flow through the meter (i.e. no conditioned water being used).
4. Open a nearby conditioned water faucet.
5. The number in the display should count upward from 0 and reset for each gallon of flow (at 200 on some models, for example). 1 gallon = 3.78 liters.
6. If the display reading does not change with the faucet open, pull the wire harness from the valve outlet port (See Figure 111).



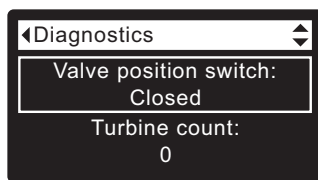
**FIG. 111**

7. Pass a small magnet back and forth in front of the sensor.
- 8a. If the displayed **Turbine Count** does count upward with each pass of the magnet, disconnect the outlet plumbing and check the turbine for binding.
- 8b. If the displayed **Turbine Count** does not count upward with each pass of the magnet, the sensor is probably faulty.

## TROUBLESHOOTING - MANUAL ADVANCE RECHARGE CHECK

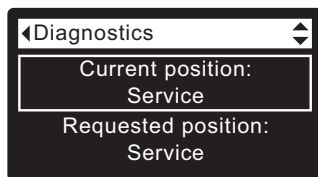
This check verifies proper operation of the position switch, gear motor, brine tank fill, brine draw, recharge flow rates, and other controller functions. Always make the Initial Checks (See Page 32) and the Manual Diagnostics (See Page 33) first.

1. Display the **Diagnostics** screen, following the procedure on Page 28.
2. Press the DOWN (▼) button to scroll through the list until **Valve position switch** is displayed (See Figure 112).



**FIG. 112**

3. Verify that when the switch plunger is down (into one of the detents on the valve motor cam), this screen reads **Open**. When the valve cam is rotating (for example, after Step 7, below), the switch plunger will be up and this screen should read **Closed**.
4. Press the UP (▲) button to scroll through the list until **Current position** is displayed (See Figure 113).



**FIG. 113**

5. Verify that the valve position indicator on the motor cam agrees with the position displayed on the screen
6. Remove the brinewell cover.
7. With the Diagnostics screen displayed, press the RIGHT (▶) button once to advance the valve from **Service** to **Fill**.
8. Shine a flashlight into the brinewell and observe fill water entering the tank.
9. If water does not enter the tank, look for an obstructed nozzle / venturi, fill flow plug or brine tube (See Figure 106 on Page 30).
10. After verifying fill, press the RIGHT (▶) button once to move the valve into **Brine\***. A slow flow of water to the drain will begin. Verify brine draw from the brine tank by shining the flashlight into the brinewell to observe a noticeable drop in the liquid level.

\* If the 2nd Backwash option is set (See Page 23), the valve will enter backwash and fast rinse before brine.

11. If the unit does not draw brine, check for:
  - Dirty or defective nozzle / venturi (See Page 30)
  - Nozzle / venturi not seated on the gasket or gasket not sealing properly
  - Restriction in valve drain, causing back pressure (bends, kinks, elevated too high, etc.)
  - Obstruction in valve or brine tubing
  - Internal valve fault (obstructed outlet disc, wave washer faulty etc.)
12. With the Diagnostics screen displayed, once again press the RIGHT (▶) button to advance the valve to **Backwash**.
13. Look for a fast flow of water from the drain hose. If flow is slow, check for a plugged top distributor, backwash flow plug or drain hose
14. With the Diagnostics screen displayed, once again press the RIGHT (▶) button to advance the valve to **Fast rinse**.
15. Again, look for a fast flow of water from the drain hose. Allow the unit to rinse for several minutes to flush out any brine that may remain from the brine cycle test.
16. With the Diagnostics screen displayed, once again press the RIGHT (▶) button to return the valve to the **Service** position.

**IMPORTANT:** Always return the valve to the **Service** position before exiting this procedure.

## OTHER SERVICE

**Hard Water Bypass** (Hard water “bleeds” into conditioned water supply):

1. Faulty inlet disc, seal or wave washer (See Pages 42 through 47).
2. Missing or faulty o-ring(s) at valve connection to riser pipe.

**Water Leaks from Drain Hose** during service:

1. Faulty inlet disc, seal or wave washer.
2. Faulty o-ring on inlet disc shaft.
3. Faulty outlet disc, seal or wave washer.

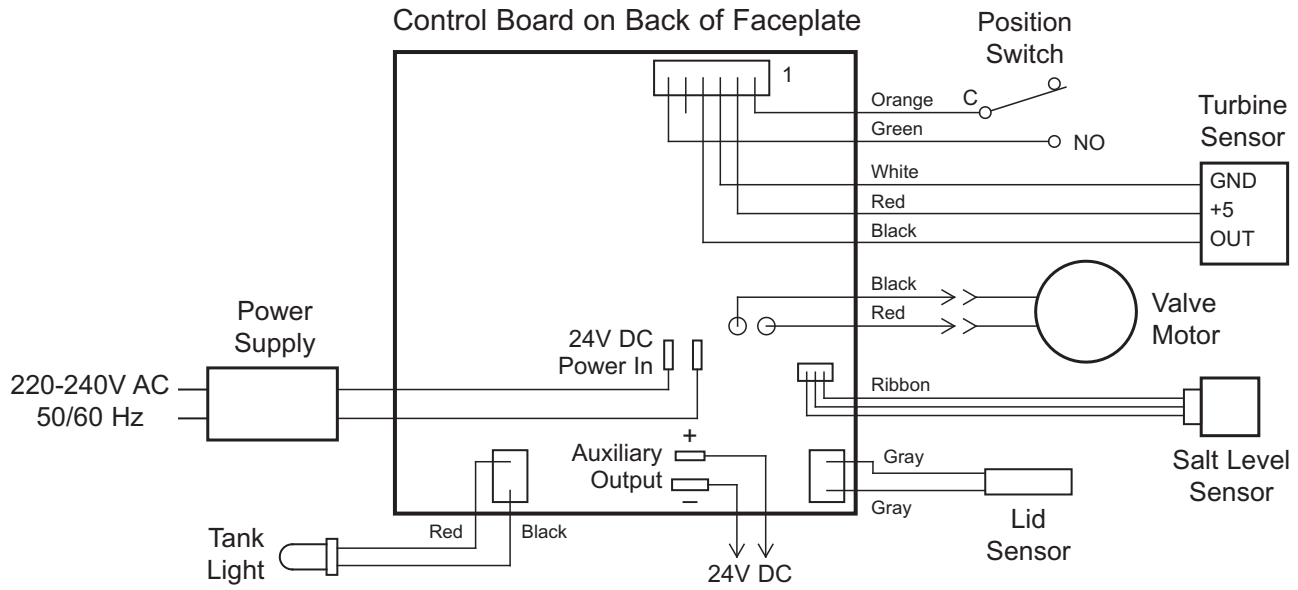
**Flooded Salt Tank:**

1. Nozzle / venturi plugged.
2. Faulty valve seals.
3. Restricted or plugged backwash / fast rinse controls.
4. Restricted or plugged drain line.

**Water Has Salty Taste:**

1. House water pressure low. Adjust well pump.
2. Partially restricted valve drain hose, top distributor, backwash flow plug, resin tank internal riser pipe, or bottom distributor.
3. Backwash and fast rinse times have been reduced from default settings.
4. Wrong model code.

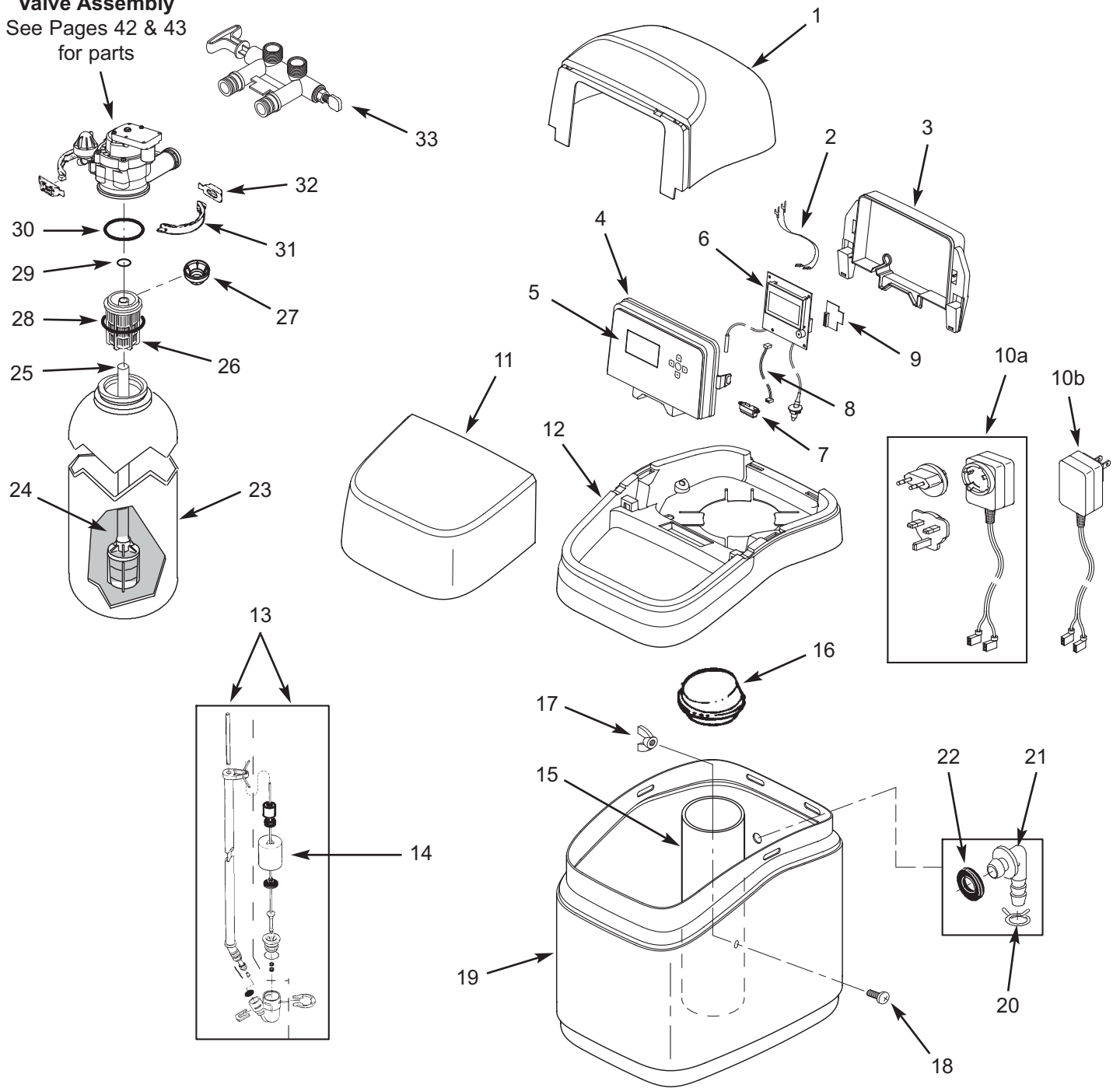
**WIRING SCHEMATIC**



**FIG. 114**

**ECOWATER SYSTEMS CONDITIONER ASSEMBLY**  
(eVOLUTION Models 100 Compact & 200 Compact)

**Valve Assembly**  
See Pages 42 & 43  
for parts



## ECOWATER SYSTEMS CONDITIONER ASSEMBLY

(eVOLUTION Models 100 Compact & 200 Compact)

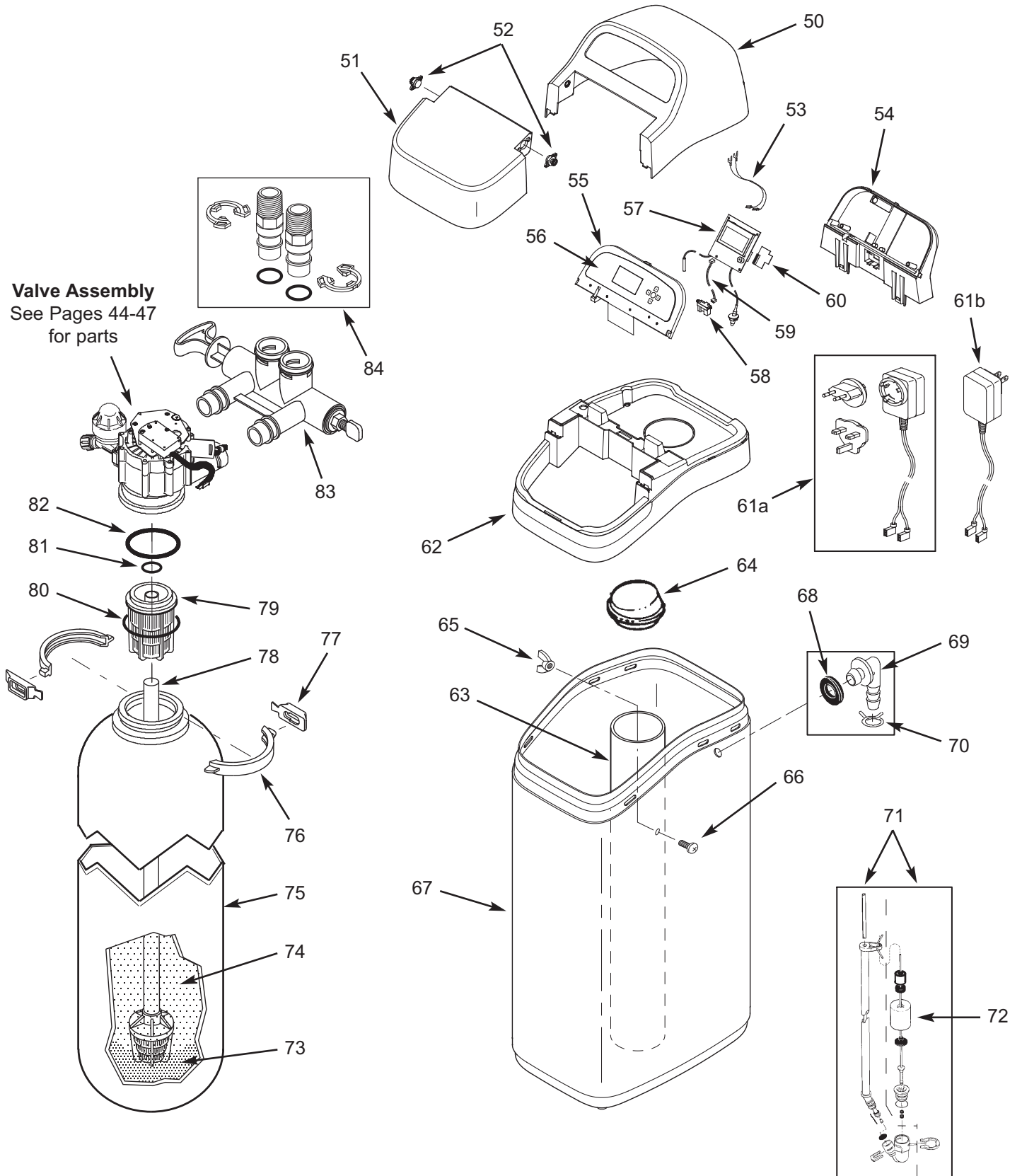
Key No.	Part No.	Description
1	7353292	Cover, Top
2	7250826	Power Cable
3	7353284	Support, Faceplate
–	7357848	Repl. Faceplate Assembly (includes Key Nos. 4-8)
4	↑	Faceplate
5	↑	Keypad/Decal
6	↑	Electronic Controller (PWA), with Tank Light Assembly & Lid Sensor
–	7357872	Repl. Salt Level Sensor Assembly (includes Key Nos. 7 & 8)
7	↑	Salt Level Sensor, Short Range (also incl. in Repl. Faceplate Asm.)
8	↑	Cable, Salt Level Sensor (also incl. in Repl. Faceplate Asm.)
9	7341520	Repl. Wi-Fi Board
10a	7366130	Power Supply, 24V DC, with Snap-in Plugs for Europe & UK
10b	7351054	Power Supply, 24V DC, with Plug for North America *
11	7353268	Salt Lid
12	7353250	Rim
13	7310113	Brine Valve Assembly, (100 Compact)
	7310147	Brine Valve Assembly, (200 Compact)
14	7269516	Float, Stem & Guide Assembly (100 Compact)
	7269508	Float, Stem & Guide Assembly (200 Compact)
15	7267043	Brinewell (100 Compact)
	7326928	Brinewell (200 Compact)
16	0500283	Cover, Brinewell (100 Compact)
	7155115	Cover, Brinewell (200 Compact)

Key No.	Part No.	Description
–	7357822	Brinewell Mounting Hardware Kit, (includes Key Nos. 17 & 18)
17	↑	Nut
18	↑	Screw
19	7353137	Repl. Brine Tank (100 Compact)
	7353145	Repl. Brine Tank (200 Compact)
–	7331258	Overflow Hose Adaptor Kit (includes Key Nos. 20-22)
20	↑	Hose Clamp *
21	↑	Adaptor Elbow
22	↑	Grommet
23	RMH001	Resin, per liter
	30437	Resin, 25 liter bag
24	7268950	Resin Tank, 22.9 cm dia. x 35.6 cm (100 Compact)
	7256377	Resin Tank, 20.3 cm dia. x 48.3 cm (200 Compact)
25	7105047	Repl. Bottom Distributor
26	7088855	Top Distributor (100 Compact)
	7077870	Top Distributor (200 Compact)
27	7265025	Screen (100 Compact only)
–	7112963	Distributor O-Ring Kit (includes Key Nos. 28-30)
28	↑	O-Ring, 69.9 x 76.2 mm
29	↑	O-Ring, 20.6 x 27.0 mm
30	↑	O-Ring, 73.0 x 82.6 mm
–	7331177	Tank Neck Clamp Kit (includes 2 ea. of Key Nos. 31 & 32)
31	↑	Clamp Section (2 req.)
32	↑	Retainer Clip (2 req.)
33	7328051	Blending Bypass Valve, 3/4", Threaded *
■	7327631	Blending Bypass Valve, 3/4", Clip Style *

■ Not illustrated

\* Not included with conditioner/refiner

**ECOWATER SYSTEMS CONDITIONER ASSEMBLY**  
(eVOLUTION Models 300 Boost, 400 Boost, 500 Power & Refiners)



## ECOWATER SYSTEMS CONDITIONER ASSEMBLY

(eVOLUTION Models 300 Boost, 400 Boost, 500 Power & Refiners)

Key No.	Part No.	Description
–	7354808	Cover Assembly (includes Key Nos. 50-52)
50	↑	Cover, Top
51	↑	Salt Lid, with magnet
52	↑	Damper/Hinge (2 req.)
53	7250826	Power Cable
54	7367851	Support, Faceplate
–	7357856	Repl. Faceplate Assembly (includes Key Nos. 55-59)
55	↑	Faceplate
56	↑	Keypad/Decal
57	↑	Electronic Controller (PWA), with Tank Light Assembly & Lid Sensor
–	7357880	Repl. Salt Level Sensor Assembly (includes Key Nos. 58 & 59)
58	↑	Salt Level Sensor, Long Range (also incl. in Repl. Faceplate Asm.)
59	↑	Cable, Salt Level Sensor (also incl. in Repl. Faceplate Asm.)
60	7341520	Repl. Wi-Fi Board
61a	7366130	Power Supply, 24V DC, with Snap-in Plugs for Europe & UK
61b	7351054	Power Supply, 24V DC, with Plug for North America *
62	7353307	Rim, 300 Boost, 400 Boost & 500 Power
	7357521	Rim, Refiner Boost & Refiner Power
63	7267027	Brinewell (300 Boost & Refiner Boost)
	7109871	Brinewell (400 Boost, 500 Power & Refiner Power)
64	7155115	Cover, Brinewell
–	7357822	Brinewell Mounting Hardware Kit, (includes Key Nos. 65 & 66)
65	↑	Nut
66	↑	Screw
67	7353179	Repl. Brine Tank (300 Boost & Refiner Boost)
	7353187	Repl. Brine Tank (400 Boost, 500 Power & Refiner Power)
–	7331258	Overflow Hose Adaptor Kit (includes Key Nos. 68-70)
68	↑	Grommet
69	↑	Adaptor Elbow
70	↑	Hose Clamp *

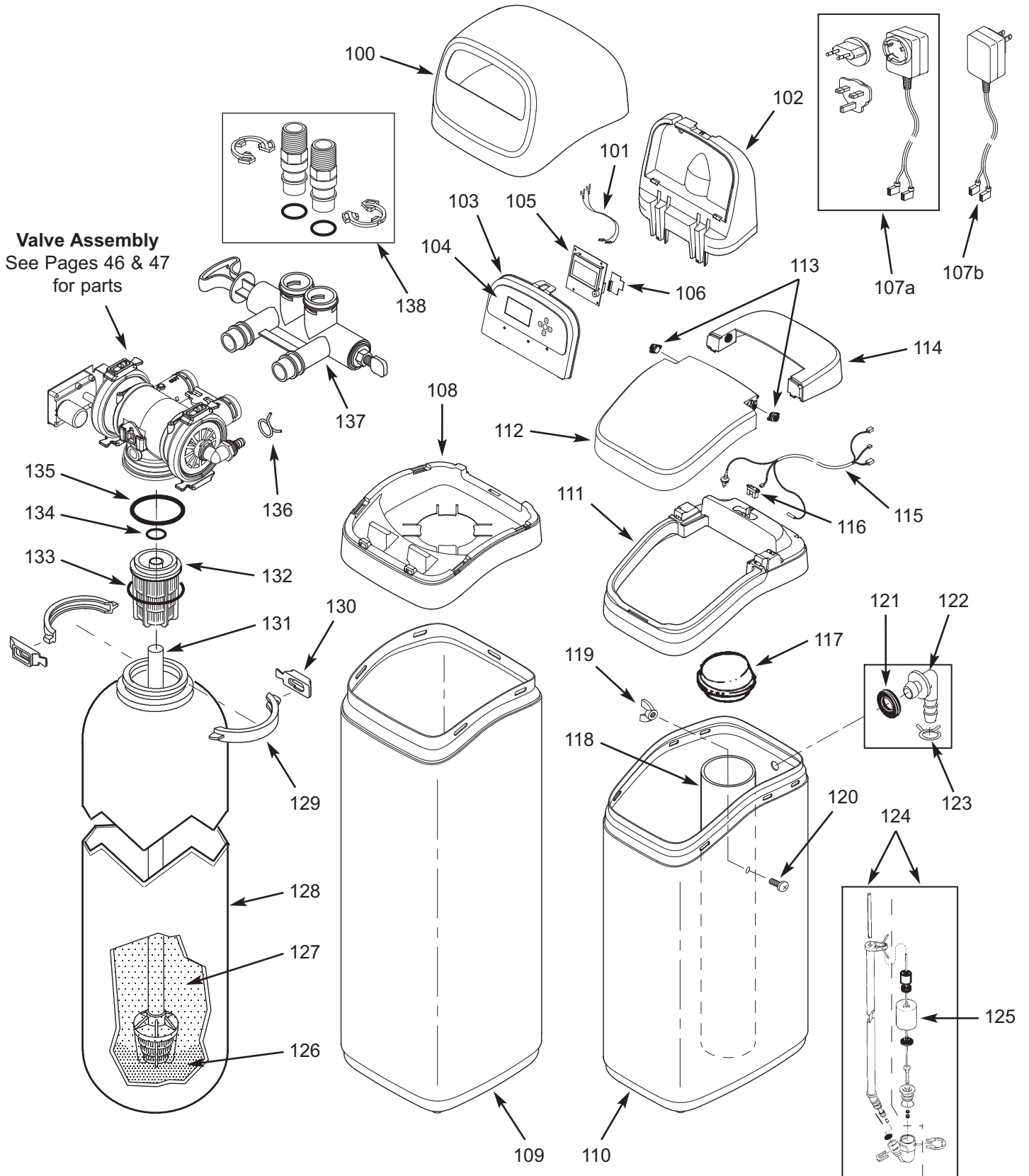
Key No.	Part No.	Description
71	7310163	Brine Valve Assembly, (300 Boost & Refiner Boost)
	7310210	Brine Valve Assembly, (400 Boost, 500 Power & Refiner Power)
72	7293395	Float, Stem & Guide Assembly (300 Boost & Refiner Boost)
	7327568	Float, Stem & Guide Assembly (400 Boost, 500 Power & Refiner Power)
73	WSM001	Gravel, 8 kg req.
74	RMH001	Resin, per liter
	30437	Resin, 25 liter bag
75	7264037	Resin Tank, 20.3 cm dia. x 63.5 cm (300 Boost)
	7304235	Resin Tank, 20.3 cm dia. x 88.9 cm (400 Boost)
	7113066	Resin Tank, 25.4 cm dia. x 88.9 cm (500 Power)
	7342110	Filled Media Tank, 20.3 cm dia. x 63.5 cm (Refiner Boost) ❶
	7342128	Filled Media Tank, 25.4 cm dia. x 88.9 cm (Refiner Power) ❶
–	7331177	Tank Neck Clamp Kit (includes 2 ea. of Key Nos. 76 & 77)
76	↑	Clamp Section (2 req.)
77	↑	Retainer Clip (2 req.)
78	7105047	Repl. Bottom Distributor
79	7077870	Top Distributor
–	7112963	Distributor O-Ring Kit (includes Key Nos. 80-82)
80	↑	O-Ring, 69.9 x 76.2 mm
81	↑	O-Ring, 20.6 x 27.0 mm
82	↑	O-Ring, 73.0 x 82.6 mm
83	7329594	Blending Bypass Valve, 1" *
84	7342704	Installation Adaptor Kit, 1" * (2 ea. adaptors, o-rings & clips)

■ Not illustrated

❶ Filled media tank for refiner includes activated carbon, resin, top and bottom distributors, associated o-rings, neck clamp kit and shipping cap, assembled.

\* Not included with conditioner/refiner

**ECOWATER SYSTEMS CONDITIONER ASSEMBLY**  
(eVOLUTION Model 600 Power)



## ECOWATER SYSTEMS CONDITIONER ASSEMBLY

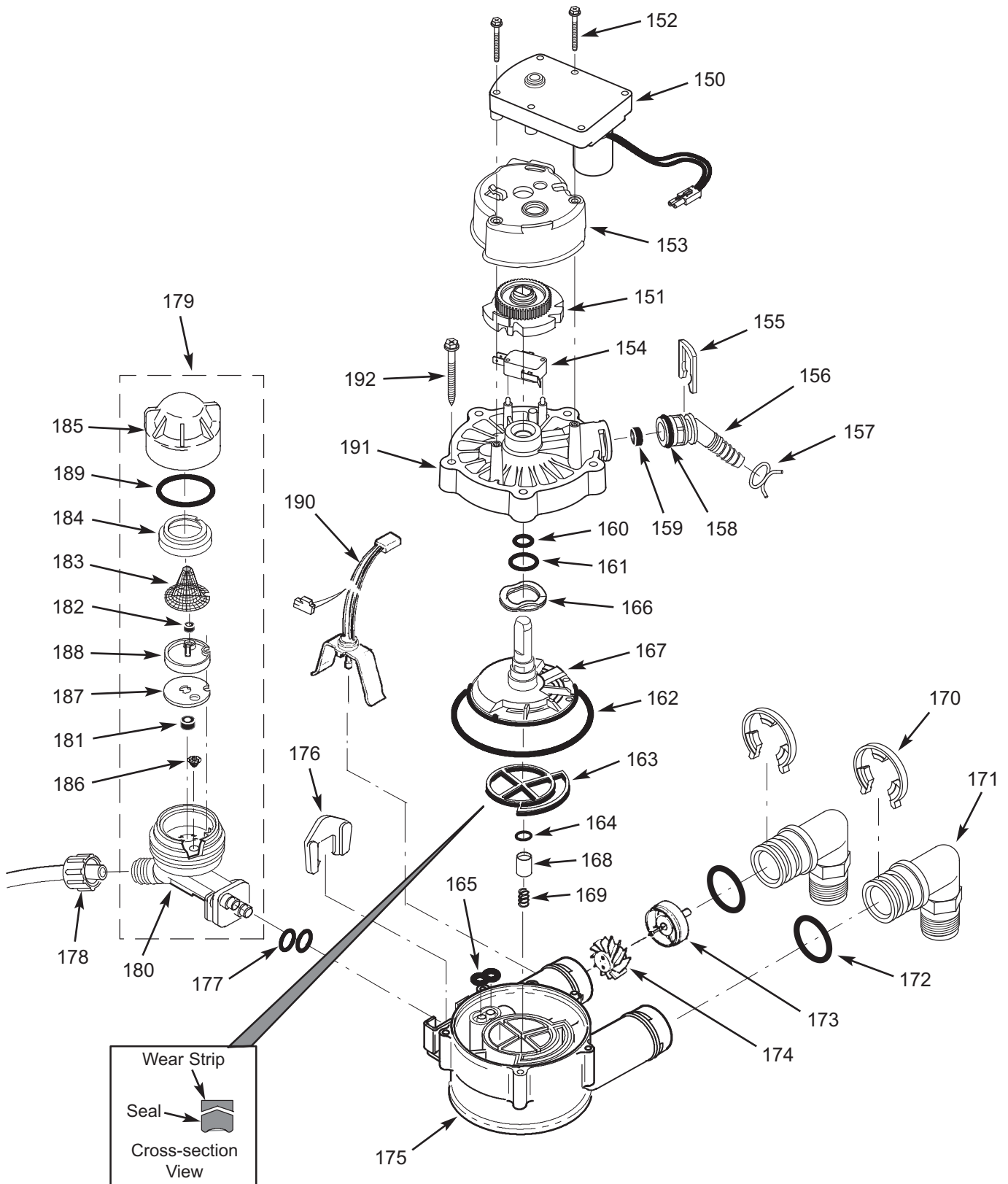
(eVOLUTION Model 600 Power)

Key No.	Part No.	Description
100	7353365	Cover, Top
101	7250826	Power Cable
102	7353381	Support, Faceplate
–	7365647	Repl. Faceplate Assembly (includes Key Nos. 103-105 & 116)
103	↑	Faceplate
104	↑	Keypad/Decal
105	↑	Electronic Controller (PWA)
106	7341520	Repl. Wi-Fi Board
107a	7366130	Power Supply, 24V DC, with Snap-in Plugs for Europe & UK
107b	7351054	Power Supply, 24V DC, with Plug for North America *
108	7353357	Rim
109	7353234	Shroud
110	7353187	Repl. Brine Tank
111	7362403	Rim, Brine Tank
–	7364162	Cover Assembly, Brine Tank (includes Key Nos. 112-114)
112	↑	Salt Lid, with magnet
113	↑	Damper/Hinge (2 req.)
114	↑	Cover, Brine Tank
115	7363514	Cable, Brine Tank
116	7365736	Salt Level Sensor, Long Range
117	7155115	Cover, Brinewell
118	7109871	Brinewell
–	7357822	Brinewell Mounting Hardware Kit, (includes Key Nos. 119 & 120)
119	↑	Nut
120	↑	Screw

Key No.	Part No.	Description
–	7331258	Overflow Hose Adaptor Kit (includes Key Nos. 121-123)
121	↑	Grommet
122	↑	Adaptor Elbow
123	↑	Hose Clamp *
124	7310210	Brine Valve Assembly
125	7327568	Float, Stem & Guide Assembly
126	WSM001	Gravel, 4.5 kg req.
127	RMH001	Resin, per liter
	30437	Resin, 25 liter bag
128	7092202	Resin Tank, 25.4 cm dia. x 119.4 cm
–	7331177	Tank Neck Clamp Kit (includes 2 ea. of Key Nos. 129 & 130)
129	↑	Clamp Section (2 req.)
130	↑	Retainer Clip (2 req.)
131	7105047	Repl. Bottom Distributor
132	7077870	Top Distributor
–	7112963	Distributor O-Ring Kit (includes Key Nos. 133-135)
133	↑	O-Ring, 69.9 x 76.2 mm
134	↑	O-Ring, 20.6 x 27.0 mm
135	↑	O-Ring, 73.0 x 82.6 mm
136	7112882	Hose Clamp *
137	7329594	Blending Bypass Valve, 1" *
138	7342704	Installation Adaptor Kit, 1" * (2 ea. adaptors, o-rings & clips)

\* Not included with conditioner/refiner

**3/4" VALVE ASSEMBLY (eVOLUTION Models 100 Compact & 200 Compact)**

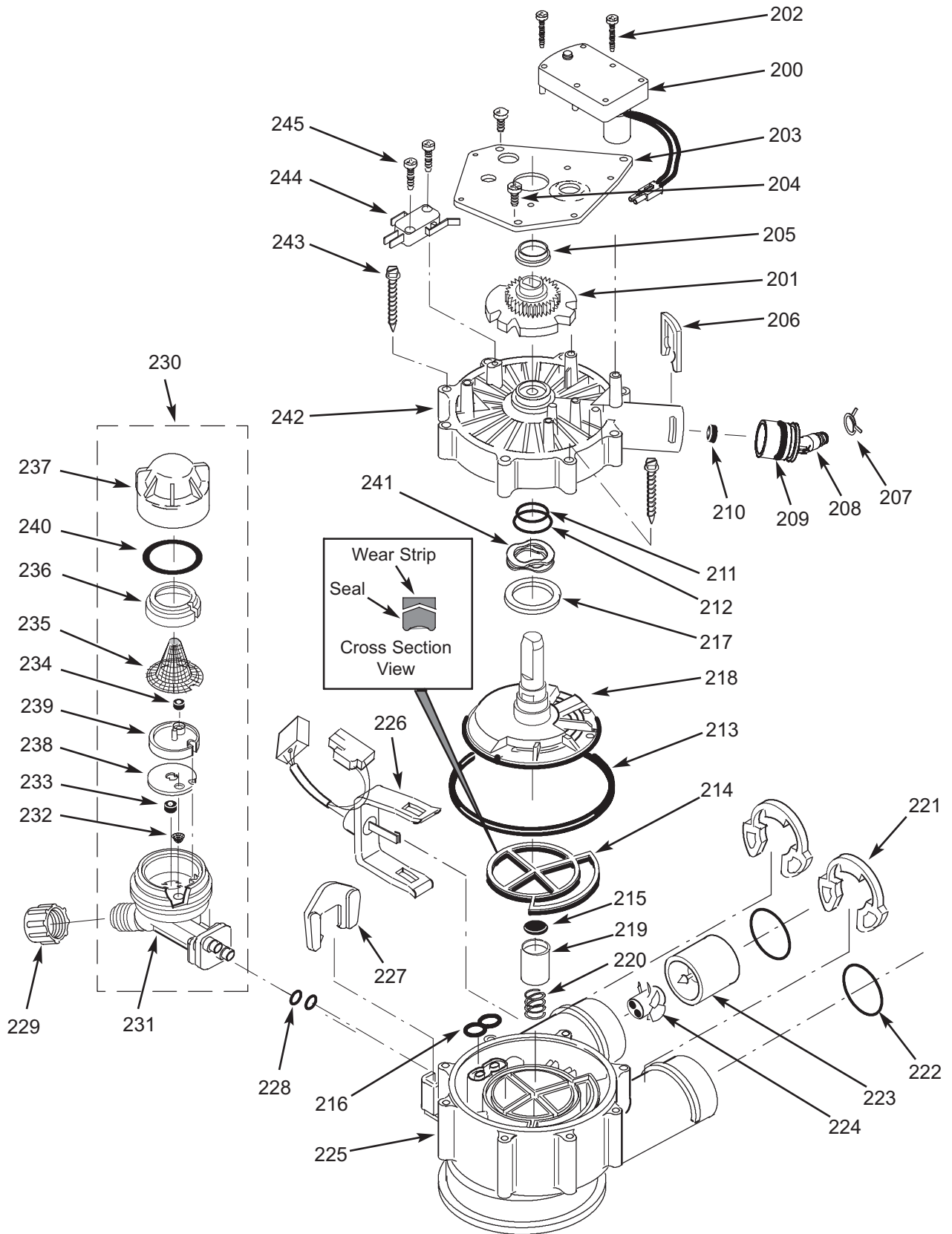


**3/4" VALVE ASSEMBLY (eVOLUTION Models 100 Compact & 200 Compact)**

Key No.	Part No.	Description
-	7384683	Motor, Cam & Gear Kit, 3/4" (includes Key Nos. 150-152)
150	↑	Motor
151	↑	Cam & Gear
152	7338111	Screw, #6-19 x 3.5 cm (2 req.)
153	7337474	Motor Mount
154	7030713	Switch
-	7331185	Drain Hose Adaptor Kit (includes Key Nos. 155-159)
155	↑	Clip, Drain
156	↑	Drain Hose Adaptor
157	↑	Hose Clamp
158	↑	O-Ring, 15.9 x 20.6 mm
159	↑	Flow Plug, 7.6 lpm
-	7129716	Seal Kit (includes Key Nos. 160-165)
160	↑	O-Ring, 11.1 x 15.9 mm
161	↑	O-Ring, 19.1 x 23.8 mm
162	↑	O-Ring, 85.7 x 92.1 mm
163	↑	Repl. Rotor Seal
164	↑	O-Ring, 9.5 x 14.3 mm
165	↑	Seal, Nozzle & Venturi
166	7082087	Wave Washer
167	7199232	Repl. Rotor & Disc
-	7342665	Drain Plug Kit, 3/4" (includes Key Nos. 164, 168 & 169)
168	↑	Plug, Drain Seal
169	↑	Spring
170	7337563	Clip, 3/4", pack of 4

Key No.	Part No.	Description
171	7255583	Installation Adaptor Elbow, 90°, pack of 2, including O-Rings (See Key No. 172), provided with 100 Compact only
172	7337571	O-Ring, 23.8 x 30.2 mm, pack of 4
-	7113040	Turbine & Support Assembly, including 2 O-Rings (See Key No. 172) & 1 ea. of Key Nos. 173 & 174
173	↑	Turbine Support & Shaft
174	↑	Turbine
175	7082053	Valve Body
176	7081201	Retainer, Nozzle & Venturi
177	7342649	O-Ring, 6.4 x 9.5 mm, pack of 2
178	1202600	Nut - Ferrule
179	7268421	Nozzle & Venturi Assembly
180	7081104	Housing, Nozzle & Venturi
181	7084607	Fill Flow Plug, .57 lpm
182	0521829	Flow Plug, .38 lpm
183	7146043	Screen
184	7167659	Screen Support
185	7199729	Cap
-	7298549	Repl. Nozzle, Venturi & Gasket Kit (includes Key Nos. 186-189)
186	↑	Cone Screen
187	↑	Gasket, Nozzle & Venturi
188	↑	Disc, Nozzle & Venturi
189	↑	O-Ring, 28.6 x 34.9 mm
190	7311779	Wire Harness, Position Switch
191	7337466	Valve Cover
192	7342657	Screw, #10-14 x 5 cm, pack of 5

**1" SINGLE DISC VALVE ASSEMBLY (Models 300 Boost, 400 Boost & Refiner Boost)**

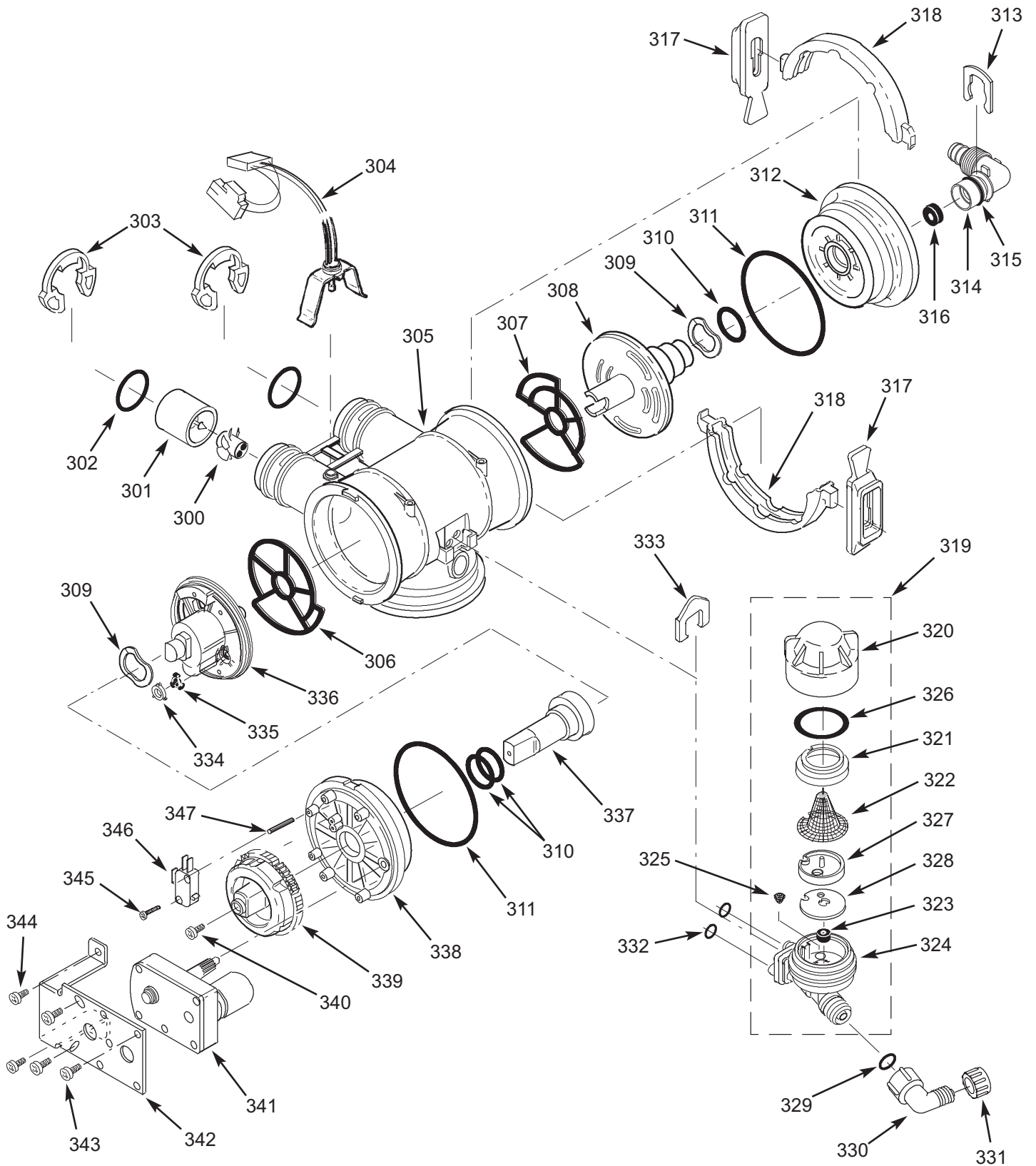


**1" SINGLE DISC VALVE ASSEMBLY (Models 300 Boost, 400 Boost & Refiner Boost)**

Key No.	Part No.	Description
–	7384691	Motor, Cam & Gear Kit, 1" (includes Key Nos. 200-202)
200	↑	Motor
201	↑	Cam & Gear
202	7224087	Screw, #8-32 x 2.5 cm (2 req.)
203	7231393	Motor Plate
204	0900857	Screw, #6-20 x .95 cm (3 req.)
205	7171250	Bearing
–	7331169	Drain Hose Adaptor Kit (includes Key Nos. 206-210)
206	↑	Clip, Drain
207	↑	Hose Clamp
208	↑	Drain Hose Adaptor
209	↑	O-Ring, 23.8 x 30.2 mm
210	↑	Flow Plug, 7.6 lpm
–	7185487	Seal Kit (includes Key Nos. 211-216)
211	↑	O-Ring, 15.9 x 20.6 mm
212	↑	O-Ring, 28.6 x 38.1 mm
213	↑	O-Ring, 114.3 x 123.8 mm
214	↑	Repl. Rotor Seal
215	↑	Seal
216	↑	Seal, Nozzle & Venturi
217	7174313	Bearing, Wave Washer
218	7185500	Repl. Rotor & Disc
–	7342712	Drain Plug Kit, 1" (includes Key Nos. 215, 219 & 220)
219	↑	Plug, Drain Seal
220	↑	Spring
221	7337589	Clip, 1", pack of 4

Key No.	Part No.	Description
222	7337597	O-Ring, 27.0 x 33.3 mm, pack of 4
–	7290931	Turbine & Support Assembly, including 2 O-Rings (See Key No. 222) & 1 ea. of Key Nos. 223 & 224
223	↑	Turbine Support & Shaft
224	↑	Turbine
225	7171145	Valve Body
226	7309811	Wire Harness, Position Switch
227	7081201	Retainer, Nozzle & Venturi
228	7342649	O-Ring, 6.4 x 9.5 mm, pack of 2
229	1202600	Nut - Ferrule
230	7238450	Nozzle & Venturi Assembly (incl. Key Nos. 227, 228 & 231-240)
231	7081104	Housing, Nozzle & Venturi
232	7095030	Cone Screen
233	1148800	Flow Plug, 1.1 lpm
234	0521829	Flow Plug, .38 lpm
235	7146043	Screen
236	7167659	Screen Support
237	7199729	Cap
–	7290957	Repl. Nozzle, Venturi & Gasket Kit (includes Key Nos. 238-240)
238	↑	Gasket, Nozzle & Venturi
239	↑	Disc, Nozzle & Venturi
240	↑	O-Ring, 28.6 x 34.9 mm
241	7175199	Wave Washer
242	7171161	Valve Cover
243	7342681	Screw, #10 x 6.7 cm, pack of 8
244	7305150	Switch
245	7140738	Screw, #4-24 x 1.9 cm (2 req.)

**1" DUAL DISC VALVE ASSEMBLY (Models 500 Power, 600 Power & Refiner Power)**



**1" DUAL DISC VALVE ASSEMBLY (Models 500 Power, 600 Power & Refiner Power)**

Key No.	Part No.	Description
–	7290931	Turbine & Support Assembly, including 2 O-Rings (See Key No. 302) & 1 ea. of Key Nos. 300 & 301), 500 Power & Refiner Power
	7331703	Turbine & Support Assembly (includes 1 ea. of Key Nos. 300, 301 & 2 ea. of Key No. 302), 600 Power
300	↑	Turbine
301	↑	Turbine Support & Shaft
302	7337597	O-Ring, 27.0 x 33.3 mm, pack of 4
303	7337589	Clip, 1", pack of 4
304	7309811	Wire Harness w/pos. switch conn.
305	7159949	Disc Valve Housing
306	7334133	Outlet End Seal ❶
307	7334125	Inlet End Seal ❶
–	7135270	Inlet & Outlet End Seal Kit (includes 1 ea. of Key Nos. 306 & 307)
308	7214286	Inlet Disc, single ❶
	7368475	Inlet Disc, pack of 10
309	7058216	Wave Washer (2 req.)
310	7170220	O-Ring, 19.1 x 23.8 mm (3 req.) ❶
311	7170296	O-Ring, 73.0 x 82.6 mm (2 req.)
312	7077498	Inlet End Cap
313	7142942	Clip, Drain
314	7219066	Drain Elbow
315	7170327	O-Ring, 15.9 x 20.6 mm
316	7097969	Flow Plug, Fast Rinse, 11.3 lpm
–	7331177	Tank Neck Clamp Kit (includes 2 ea. of Key Nos. 317 & 318)
317	↑	Retainer Clip (4 req.) ❷
318	↑	Clamp Section (4 req.) ❷

Key No.	Part No.	Description
319	7091866	Nozzle & Venturi Assembly (includes Key Nos. 320-328)
320	7199729	Cap
321	7167659	Screen Support
322	7146043	Screen
323	1148800	Flow Plug, 1.1 lpm
324	7081104	Housing, Nozzle & Venturi
325	7095030	Cone Screen
–	7290957	Repl. Nozzle, Venturi & Gasket Kit (includes Key Nos. 326-328)
326	↑	O-Ring, 28.6 x 34.9 mm
327	↑	Disc, Nozzle & Venturi
328	↑	Gasket, Nozzle & Venturi
329	7292323	O-Ring, 4.8 x 11.1 mm
330	7120526	Elbow, 90°
331	1202600	Nut - Ferrule
332	7342649	O-Ring, 6.4 x 9.5 mm, pack of 2
333	7081201	Clip, Nozzle & Venturi
334	7078313	Retainer ❶
335	7104570	Flow Washer, Backwash, 6.4 lpm
336	7214278	Outlet Disc, single ❶
	7368483	Outlet Disc, pack of 10
337	7091329	Driver, Outlet Disc
338	7159965	Outlet End Cap
339	7283497	Cam & Gear
340	7203104	Washerhead Screw, #8-18 x 1.27 cm
341	7281275	Motor, incl. Key No. 342
342	7289702	Bracket, Motor
343	7168524	Screw, #10-32 x 0.8 cm (3 req.)
344	7103972	Screw, #8-18 x 1.1 cm (2 req.)
345	7140738	Screw, #4-24 x 1.9 cm
346	7145186	Switch
347	7140746	Expansion Pin

❶ Included in Disc Kit, #7218688

❷ Not all parts are shown



Your Water. Perfected.