

---

# Electronic Demand AUTOMATIC WATER CONDITIONER

## Model EP 6130

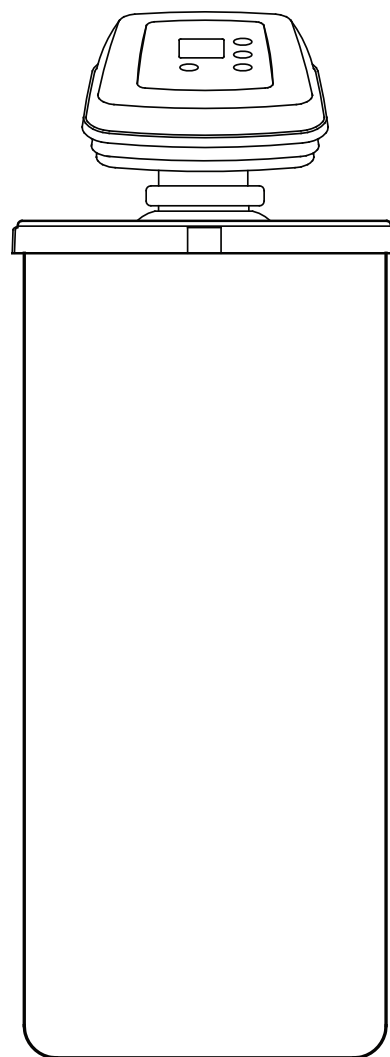

Installation

Operation

Maintenance

Repair Parts

System tested and certified by NSF International  
against NSF/ANSI Standard 44  
for hardness reduction and efficiency,  
and certified to NSF/ANSI/CAN Standard 372.



System tested and certified by the Water Quality  
Association against CSA B483.1.



C US

Manufactured and warranted by  
Water Channel Partners  
2805 Dodd Road, Suite 300  
Eagan, MN 55121

7333080 (Rev. X 4/3/25)

---

## TABLE OF CONTENTS

	<u>Page</u>
Inspect Shipment . . . . .	3
Before You Start . . . . .	3
Specifications & Dimensions . . . . .	4
Installation Requirements . . . . .	5
Typical Installation Illustrations . . . . .	6
Installation Instructions . . . . .	7-10
Programming the Electronic Controller . . . . .	11-12
Controller Features / Options . . . . .	13
Adding Salt . . . . .	14
Water Softener Maintenance . . . . .	14-15
Troubleshooting . . . . .	16-18
Wiring Schematic . . . . .	19
Exploded View & Parts List . . . . .	20-23

### WATER SOFTENER WARRANTY

**Warrantor: Water Channel Partners, 2805 Dodd Road, Suite 300, Eagan, MN 55121**

Warrantor guarantees to the original purchaser when the product is purchased from an authorized dealer, and when installed and maintained in accordance with the instructions, that::

**One Year Full Warranty:**

- For a period of one (1) year from the date the product is delivered, all parts will be free from defects in materials and workmanship and will perform in accordance with their written specifications.

**Limited Warranties:**

- For a period of ten (10) years from the date the product is delivered, the salt storage tank and resin/mineral tank will not rust, corrode, leak, burst, or in any other manner, fail to perform in accordance with their written specifications.
- For a period of three (3) years from the date the product is delivered, the electronic control board and valve body will be free of defects in materials and workmanship and will perform in accordance with their written specifications.

If, during such respective period, a part proves to be defective, Warrantor will ship a replacement part, directly to your home, without charge. If a repair or replacement part is unavailable, Warrantor may refund the original purchase price. After the first year, labor necessary to maintain this product is not covered by the product warranty.

**General Provisions**

Damage to any part of this water softener because of misuse, misapplication, neglect, alteration, accident, installation or operation contrary to the product instructions, or damage caused by any unusual force of nature such as, but not limited to, freezing, flood, hurricane, tornado, or earthquake is not covered by this warranty. In all such cases, regular parts and service charges will apply.

We assume no warranty liability in connection with this water softener other than specified herein. This warranty is in lieu of all other warranties, expressed or implied, including warranties of fitness for a particular purpose. We do not authorize any person or representative to assume for us any other obligations on the sale of this water softener.

Should a defect or malfunction occur, contact your contractor. If you are unable to contact your contractor, return the part, freight prepaid, directly to the factory at the address below. Enclose with the part a full description of the problem, with your name, full address, date purchased, model and serial numbers, and selling contractor's name and address. We will repair or replace the part and return it to you at no cost if our repair department determines it to be defective under the terms of the warranty.

This warranty gives you specific legal rights and you may have other rights which vary from state to state.

This water softener is manufactured by  
Water Channel Partners, 2805 Dodd Road, Suite 300, Eagan, MN 55121

# Inspect Shipment

The parts required to assemble and install the water softener are included with the unit. Thoroughly check the water softener for possible shipping damage and parts loss. Also inspect and note any damage to the shipping carton.

Remove and discard (or recycle) all packing materials. To avoid loss of small parts, we suggest you keep the small parts in the parts bag until you are ready to use them.

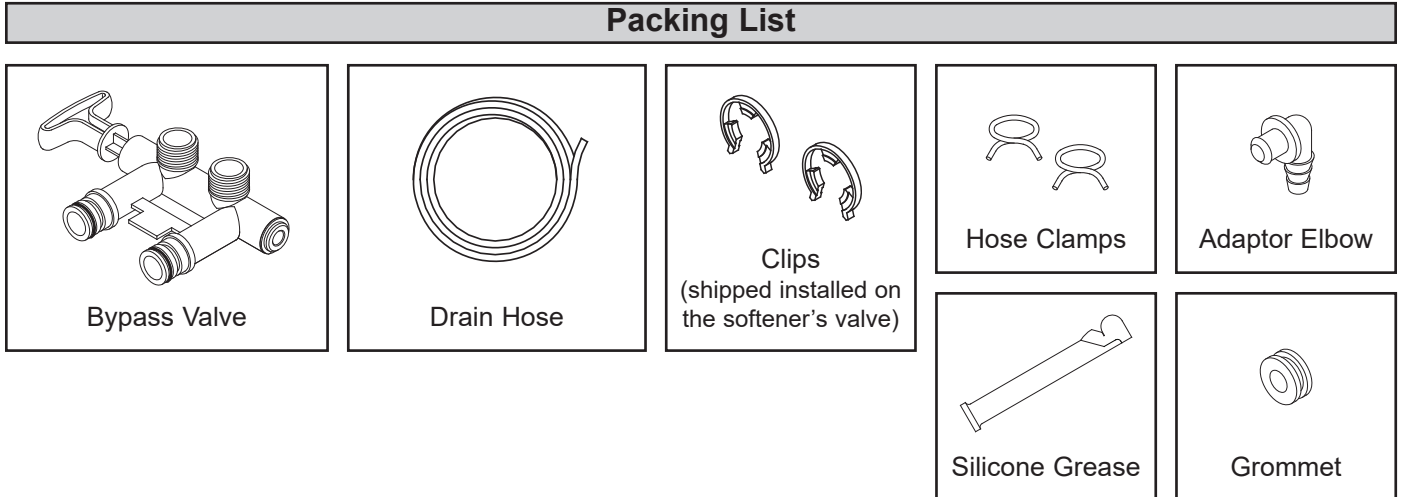

FIG. 1

## Before You Start

- The water softener requires a minimum water flow of 3 gallons per minute at the inlet. Maximum allowable inlet water pressure is 125 psi. If daytime pressure is over 80 psi, nighttime pressure may exceed the maximum. Use a pressure reducing valve if necessary (Adding a pressure reducing valve may reduce the flow). If your home is equipped with a back flow preventer, an expansion tank must be installed in accordance with local codes and laws.
- The water softener works on 24V DC electrical power, supplied by a direct plug-in power supply (included). Be sure to use the included power supply and plug it into a nominal 120V, 60 Hz household outlet that is in a dry location only, grounded and properly protected by an overcurrent device such as a circuit breaker or fuse.
- Do not use this system to treat water that is microbiologically unsafe or of unknown quality without adequate disinfection upstream or downstream of the system.



European Directive 2002/96/EC requires all electrical and electronic equipment to be disposed of according to Waste Electrical and Electronic Equipment (WEEE) requirements. This directive or similar laws are in place nationally and can vary from region to region. Please refer to your state and local laws for proper disposal of this equipment.

# Specifications & Dimensions

This model is efficiency rated. The efficiency rating is valid only at the minimum salt dose. This softener has a demand initiated regeneration (D.I.R.) feature that complies with specific performance specifications intended to minimize the amount of regenerant brine and water used in their operation.

This softener has a rated softener efficiency of not less than 3,350 grains of total hardness exchange per pound of salt (based on sodium chloride) and shall not deliver more salt than its listed rating or be operated at a sustained maximum service flow rate greater than its listed rating. This softener has been proven to deliver soft water for at least ten continuous minutes at the rated service flow rate. The rated salt efficiency is measured by laboratory tests described in NSF/ANSI Standard 44. These tests represent the maximum possible efficiency that the system can achieve. Operational efficiency is the actual efficiency after the system has been installed. It is typically less than the rated efficiency, due to individual application factors including water hardness, water usage, and other contaminants that reduce a softener's capacity.

	<b>Model EP 6130</b>
Model Code	E6130
Rated Softening Capacity (Grains @ Salt Dose)	11,800 @ 2.3 lbs. 25,300 @ 7.4 lbs. 30,200 @ 12.5 lbs.
Rated Efficiency (Grains/Pound of Salt @ Minimum Salt Dose)	5,090 @ 2.3 lbs.
Water Used During Regeneration @ Minimum Salt Dose	3.2 gallons / 1,000 grains
Total Water Used Per Regeneration @ Maximum Salt Dose	39.5 gallons
Rated Service Flow Rate	7.3 gpm
Amount of High Capacity Ion Exchange Resin	0.78 cu. ft.
Nominal Tank Size	8" dia. x 40"
Pressure Drop at Rated Service Flow	15.0 psig
Intermittent Flow Rate @ 15 psi*	7.3 gpm
Water Supply Max. Hardness	70 gpg
Water Supply Max. Clear Water Iron	8 ppm**
Water Pressure Limits (min./max.)	20 - 125 psi***
Water Temperature Limits (min./max.)	40 - 120 °F
Minimum Water Supply Flow Rate	3 gpm
Maximum Drain Flow Rate	2.0 gpm

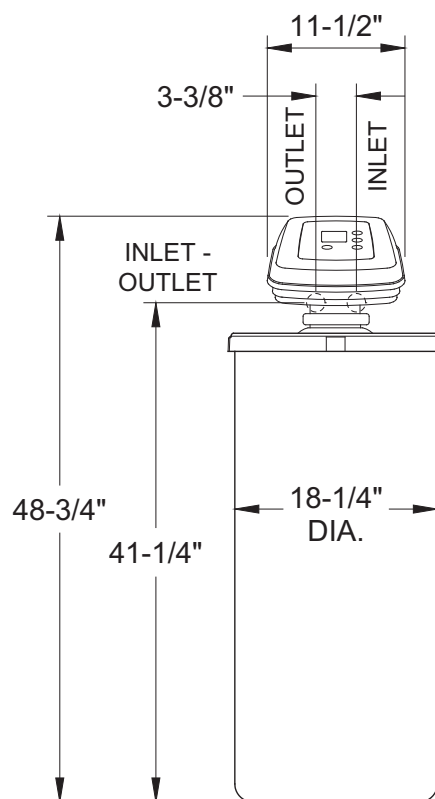

**FIG. 2**

\*Intermittent flow rate does not represent the maximum service flow rate used for determining the softener's rated capacity and efficiency. Continuous operation at flow rates greater than the service flow rate may affect capacity and efficiency performance.

\*\*Capacity to reduce clear water iron is substantiated by WQA test data. State of Wisconsin requires additional treatment if water supply contains clear water iron exceeding 5 ppm.

\*\*\*Canada working pressure limits: 1.4 - 7.0 kg/cm<sup>2</sup>.

This system conforms to NSF/ANSI 44 for the specific performance claims as verified and substantiated by test data.

**Variable Salt Dose:** The salt dose is selected by the electronic controls at regeneration time based on the amount needed.

# Installation Requirements

## LOCATION REQUIREMENTS

Consider all of the following when selecting an installation location for the water softener.

- Do not locate the water softener where freezing temperatures occur. Do not attempt to treat water over 120°F. Freezing temperatures or hot water damage voids the warranty.
- To condition all water in the home, install the water softener close to the water supply inlet, and upstream of all other plumbing connections, except outside water pipes. Outside faucets should remain on hard water to avoid wasting conditioned water and salt.
- A nearby drain is needed to carry away regeneration discharge (drain) water. Use a floor drain, laundry tub, sump, standpipe, or other options (check your local codes). See "Air Gap Requirements" and "Valve Drain Requirements" sections.
- The water softener works on 24V DC electrical power, supplied by a direct plug-in power supply (included). Provide nearby a 120V, 60 Hz electrical outlet in accordance with national and local codes.
- Always install the water softener between the water inlet and water heater. Any other installed water conditioning equipment should be installed between the water inlet and water softener (See Figure 4 below).
- Avoid installing in direct sunlight. Excessive sun heat may cause distortion or other damage to non-metallic parts.

## PLUMBING CODES

All plumbing must be completed in accordance with national, state and local plumbing codes.

In the state of Massachusetts: The Commonwealth of Massachusetts plumbing code 248-CMR shall be adhered to. A licensed plumber shall be used for this installation.

## AIR GAP REQUIREMENTS

A drain is needed for regeneration water (See Figure 3). A floor drain, close to the water softener, is preferred. A laundry tub, standpipe, etc. are other drain options. Secure valve drain hose in place. Leave an air gap of 1-1/2" between the end of the hose and the drain. This gap is needed to prevent backflow of sewer water into the water softener. Do not put the end of the drain hose into the drain.

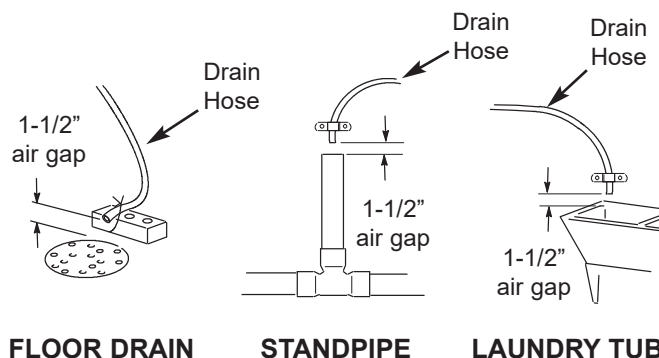

FIG. 3

## THE PROPER ORDER TO INSTALL WATER TREATMENT EQUIPMENT

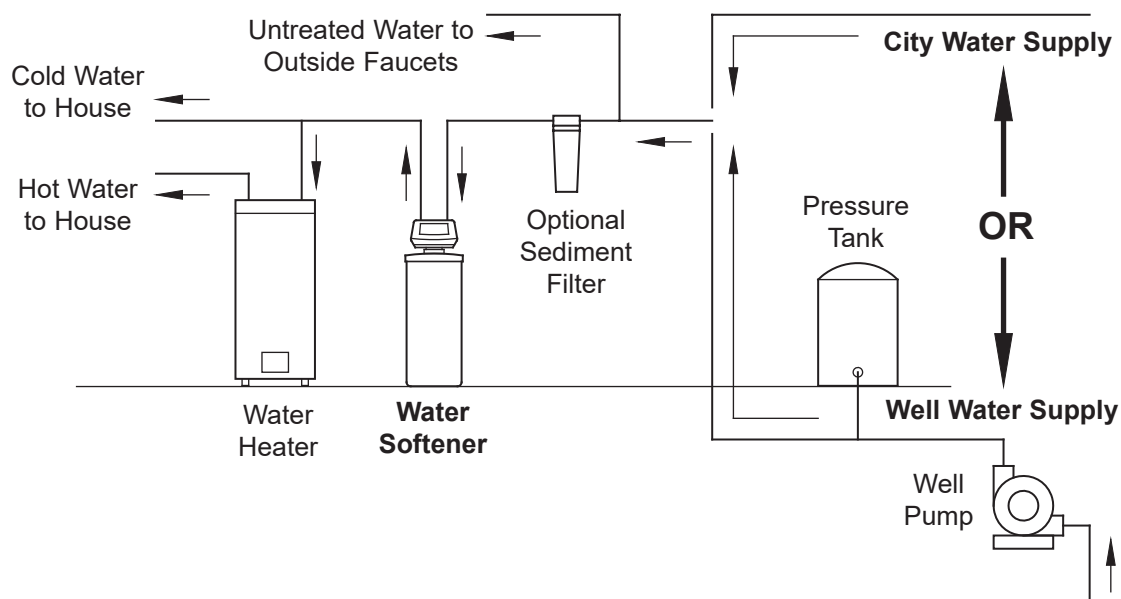
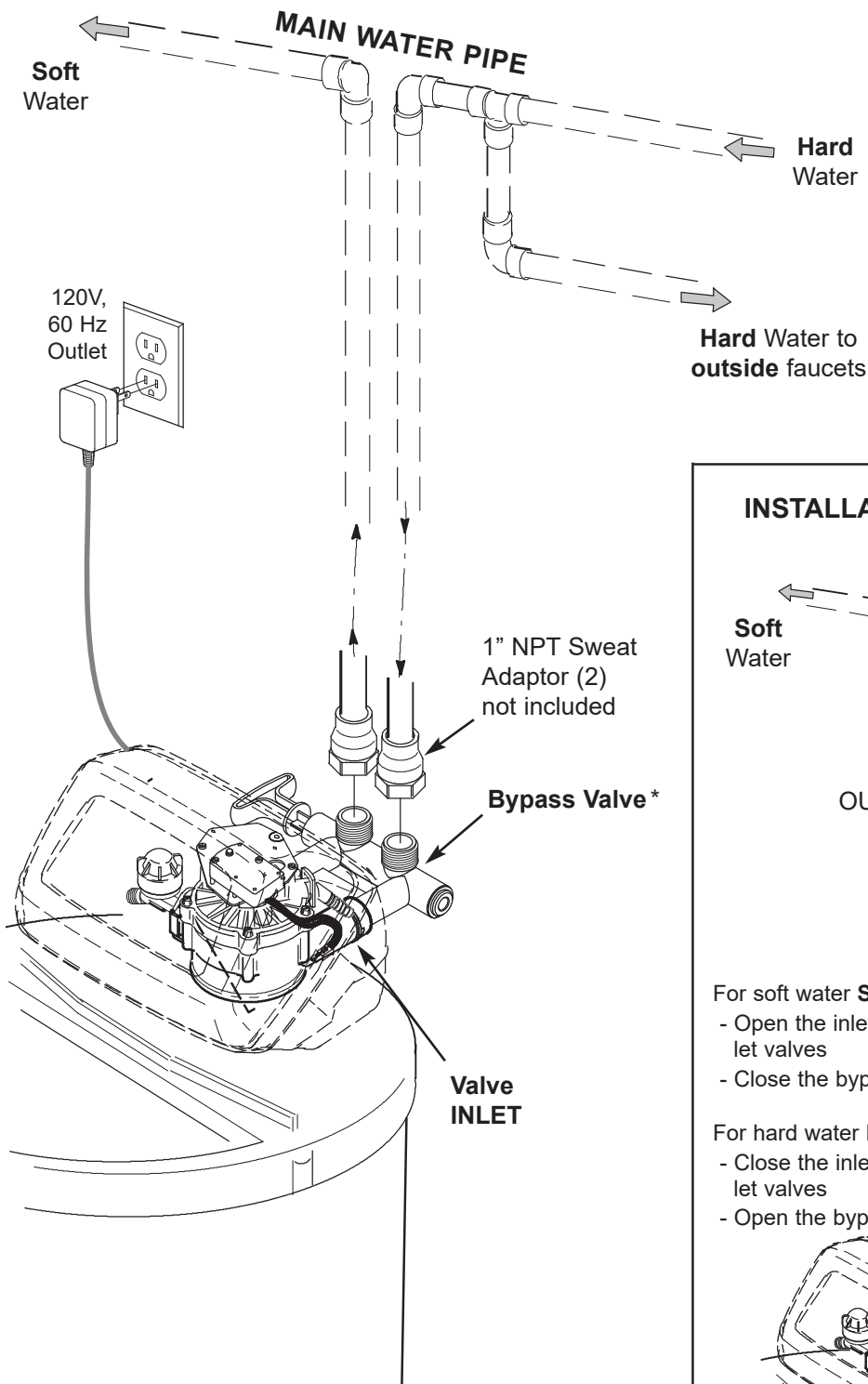
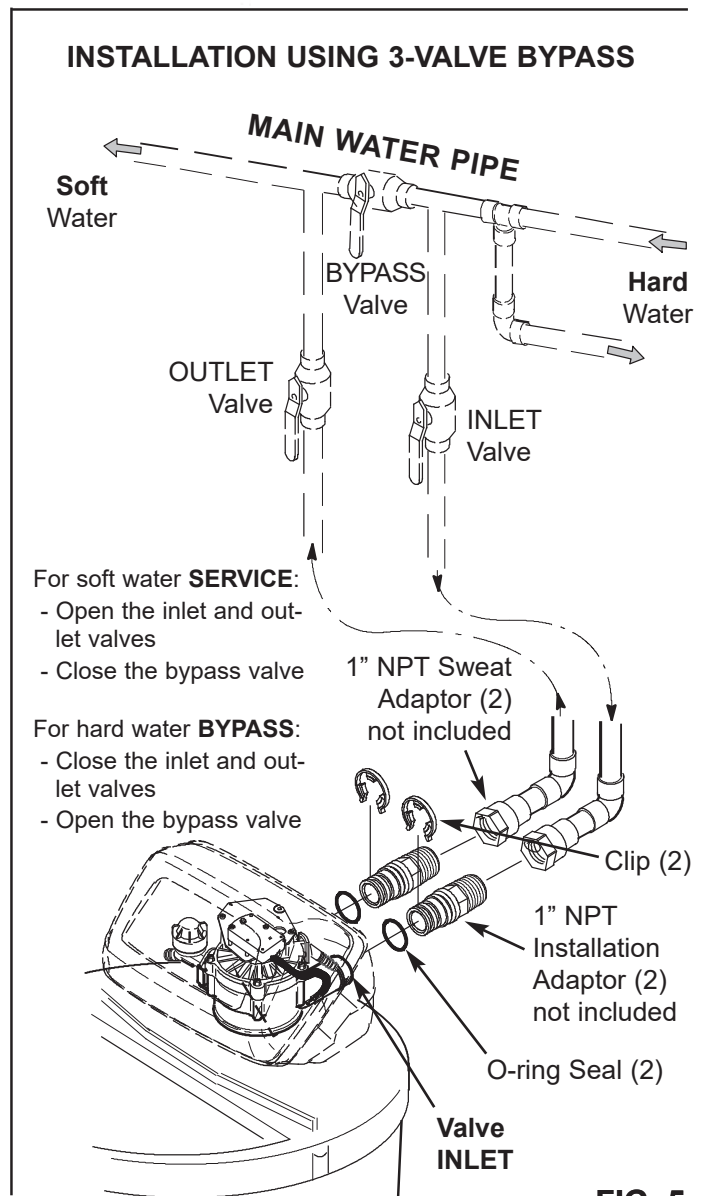
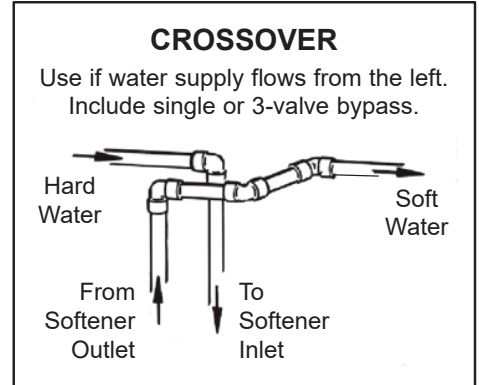

FIG. 4

# Typical Installation Illustrations



\* Included with softener. Pipe and fittings supplied by installer.



**FIG. 5**

# Installation Instructions

## 1. TURN OFF WATER SUPPLY

- a. Close the main water supply valve near the well pump or water meter.
- b. Shut off the electric or fuel supply to the water heater.
- c. Open high and low faucets to drain all water from the house pipes.

## 2. INSTALL BYPASS VALVE AND/OR PLASTIC INSTALLATION ADAPTORS:

- a. If installing a single bypass valve, push the bypass valve, with lubricated o-ring seals in place, into the valve inlet and outlet ports (See Figures 5 & 7).
  - OR -
- b. If installing a 3-valve bypass system, slide plastic installation adaptors (not included), with lubricated o-ring seals in place, into the valve inlet and outlet ports (See Figure 5).
- c. Make sure the turbine and support are firmly in place in the valve outlet, as shown in Figure 8. Blow into the valve port and observe the turbine for free rotation.
- d. Snap the two large plastic clips in place on the inlet and outlet ports, from the top, down (See Figure 9). Make sure they snap into place. Pull on the bypass valve, or installation adaptors, to make sure they are held securely in place.

## 3. MOVE THE UNIT INTO INSTALLATION POSITION

- a. Move the water softener into the desired location. Set it on a solid, level surface.

**IMPORTANT:** Do not place shims directly under the salt storage tank to level the softener. The weight of the tank, when full of water and salt, may cause the tank to fracture at the shim.

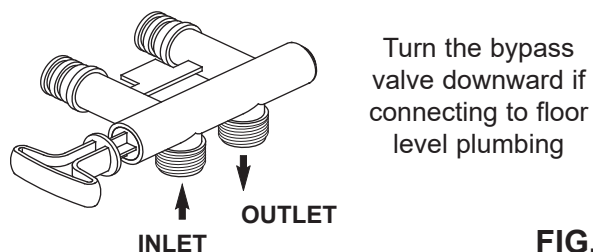
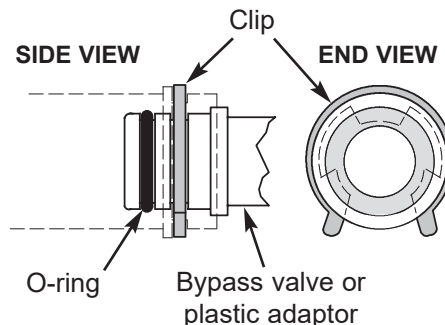
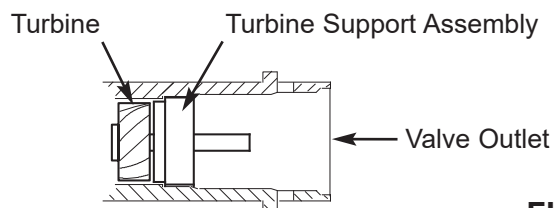
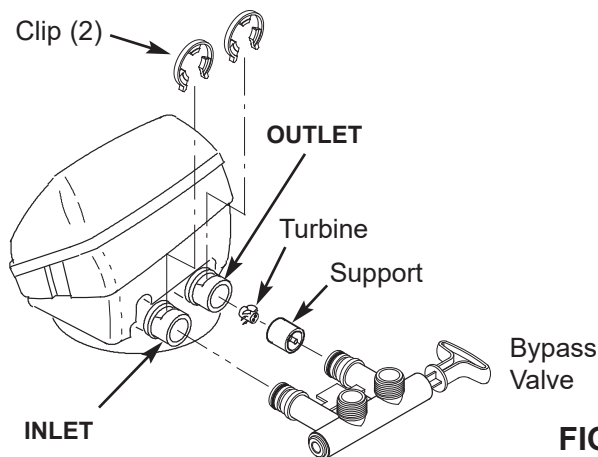
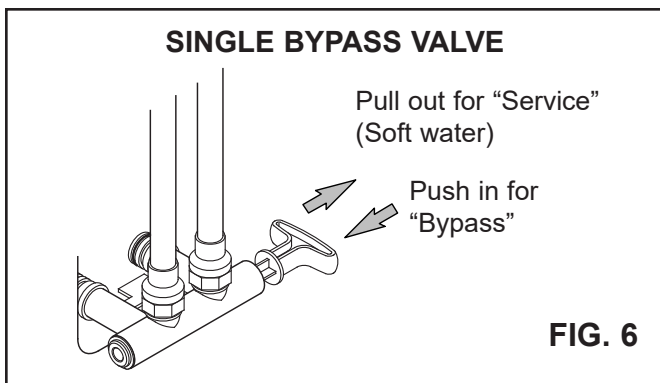

# Installation Instructions

## 4. COMPLETE INLET AND OUTLET PLUMBING

Pipe fittings must be 3/4" minimum.

Use:

- Copper pipe
- Threaded pipe
- PEX (Crosslinked Polyethylene) pipe
- CPVC plastic pipe
- Other pipe approved for use with potable water

**IMPORTANT:** Do not solder with plumbing attached to installation adaptors and single bypass valve. Soldering heat will damage the adaptors and valve. Measure, cut, and loosely assemble pipe and fittings from the main water pipe to the inlet and outlet ports of the water softener valve. Be sure to keep fittings fully together, and pipes squared and straight.

Be sure hard water supply pipe goes to the water softener valve inlet side.

**NOTE:** Inlet and outlet are marked on the water softener valve. Trace the water flow direction to be sure hard water is to inlet.

**IMPORTANT:** Be sure to fit, align and support all plumbing to prevent putting stress on the water softener valve inlet and outlet. Stress from misaligned or unsupported plumbing may cause damage to the valve.

Complete the inlet and outlet plumbing for the type of pipe you will be using.

## 5. COLD WATER PIPE GROUNDING

**CAUTION:** The house cold water pipe (metal only) is often used as a ground for the house electrical system. The 3-valve bypass type of installation, shown in Figure 5, will maintain ground continuity. If you use a plastic bypass valve at the unit, continuity is broken. To restore the ground, do the following:

a. Install a #4 copper wire across the removed section of main water pipe, securely clamping it at both ends (See Figure 11) - parts not included.

**NOTE:** Check local plumbing and electrical codes for proper installation of grounding. The installation must conform to them. In Massachusetts, plumbing codes of Massachusetts shall be conformed to. Consult with your licensed plumber.

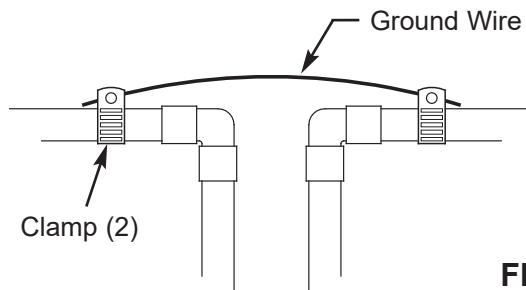

FIG. 11

## 6. INSTALL VALVE DRAIN HOSE

a. Measure, cut to needed length and connect the 3/8" inside diameter drain line (provided with some models) to the water softener valve drain fitting. Use a hose clamp to hold the hose in place.

**NOTE:** Avoid drain hose runs longer than 30 feet. Avoid elevating the hose more than 8 feet above the floor. Make the valve drain line as short and direct as possible.

**NOTE:** If codes require a rigid drain line see Figure 13.

b. Route the drain hose or copper tubing to the floor drain. Secure drain hose. This will prevent "whipping" during regenerations. See "Air Gap Requirements" section.

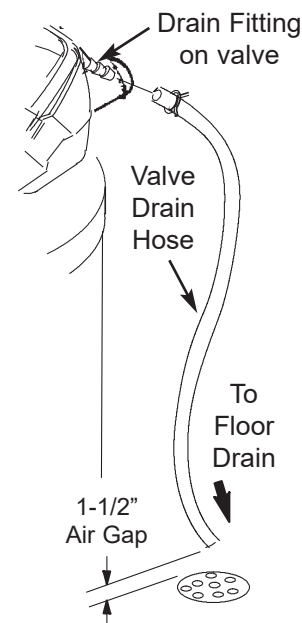

FIG. 12

### CONNECTING A RIGID VALVE DRAIN TUBE:

To adapt a copper drain tube to the softener, cut the barbed end from the drain fitting, as shown. Obtain a compression fitting (1/4" female pipe thread x 1/2" O.D. tube) and needed tubing from your local hardware store.

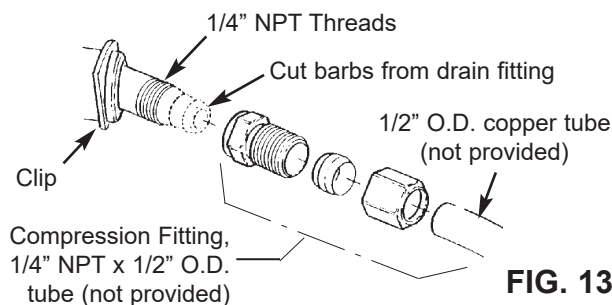

FIG. 13

# Installation Instructions

## 7. INSTALL SALT STORAGE TANK OVERFLOW FITTINGS AND HOSE

- a. Insert the rubber grommet into the 3/4" diameter hole in the salt storage tank sidewall (See Figure 14).
- b. Push the barbed end of the hose adaptor elbow into the grommet.
- c. Measure, cut to needed length and connect the 3/8" inside diameter drain line (provided with some models) to the salt storage tank overflow elbow and secure in place with a hose clamp.
- d. Route the hose to the floor drain, or other suitable drain point no higher than the drain fitting on the salt storage tank (This is a gravity drain). If the tank overfills with water, the excess water flows to the drain point. Cut the drain line to the desired length and route it neatly out of the way.

**IMPORTANT:** For proper operation of the water softener, do not connect the water softener valve drain tubing to the salt storage tank overflow hose.

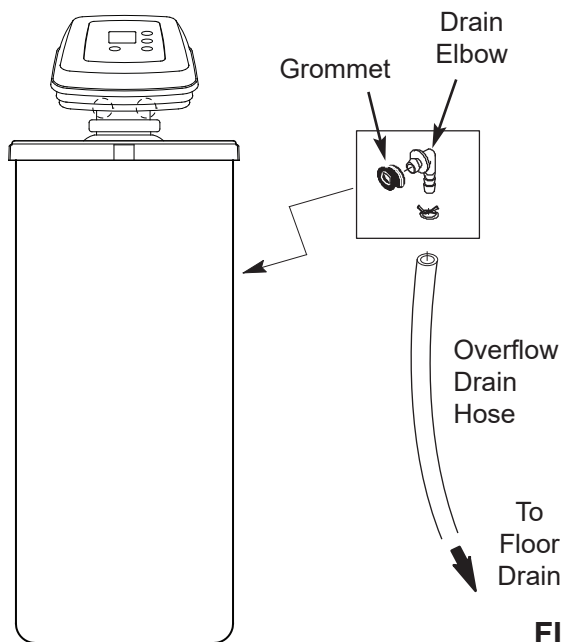

FIG. 14

## 8. TEST FOR LEAKS

To prevent air pressure in the water softener and plumbing system, complete the following steps in order:

- a. Fully open two or more softened cold water faucets close to the water softener, located downstream from the water softener.
- b. Place the bypass valve (single or 3 valve) into the "bypass" position. See Figures 5 & 6.
- c. Slowly open the main water supply valve. Run water until there is a steady flow from the opened faucets, with no air bubbles.
- d. Place bypass valve(s) in "service" or soft water position as follows:
  - Single bypass valve: Slowly move the valve stem toward "service," pausing several times to allow the water softener to fill with water.
  - 3 valve bypass: Fully close the bypass valve and open the outlet valve. Slowly open the inlet valve, pausing several times to allow the water softener to fill with water.
- e. After about three minutes, open a hot water faucet until there is a steady flow and there are no air bubbles, then close this faucet.
- f. Close all cold water faucets and check for leaks at the plumbing connections that you made.
- g. Check for leaks around clips at softener's inlet and outlet. If a leak occurs at a clip, depressurize the plumbing (turn off the water supply and open faucets) before removing clip. When removing clips at the softener's inlet or outlet, push the single bypass valve body toward the softener (See Figure 15). Improper removal may damage clips. Do not reinstall damaged clips.

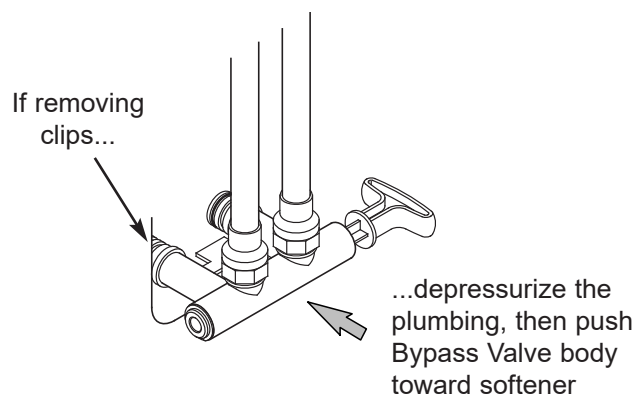

FIG. 15

---

# Installation Instructions

## 9. ADD WATER AND SALT TO THE SALT STORAGE TANK

1. Using a container, add about three gallons of clean water into the salt storage tank.
2. Add salt to the storage tank. Use nugget, pellet or coarse solar salts with less than 1% impurities.

## 10. PLUG IN THE WATER SOFTENER

During installation, the water softener wiring may be moved or jostled from place. Be sure all leadwire connectors are secure on the back of the electronic board and be sure all wiring is away from the valve gear and motor area, which rotates during regenerations.

- a. Plug the water softener into an electrical outlet that is not controlled by a switch.

**NOTE:** The water heater is filled with hard water and, as hot water is used, it will refill with conditioned water. In a few days, the hot water will be fully conditioned. To have fully conditioned hot water immediately, wait until the initial recharge is over. Then, drain the water heater (following instructions for water heater) until water runs cold.

## 11. PROGRAM THE CONTROLLER

- a. Complete the Programming Steps on the next two pages.

## 12. SANITIZE THE WATER SOFTENER / SANITIZE AFTER SERVICE

Care is taken at the factory to keep your unit clean and sanitary. Materials used to make the unit will not infect or contaminate your water supply, and will not cause bacteria to form or grow. However, during shipping, storage, installation and operation, bacteria could get into the unit. For this reason, sanitizing as follows is suggested\* when installing.

- a. Open the salt lid, remove the brinewell cover and pour about 3 oz. (6 tablespoons) of common 5.25% household bleach into the softener brinewell. Replace the brinewell cover.
- b. Make sure the bypass valve(s) is in the "service" (open) position.
- c **Start a recharge:** Press the RECHARGE button and hold for 3 seconds, until "Recharge Now" begins to flash in the display. This recharge draws the sanitizing bleach into and through the water softener. Any air remaining in the unit is purged to the drain.
- d. After the recharge has completed, fully open a cold water faucet, downstream from the softener, and allow 50 gallons of water to pass through the system. This should take at least 20 minutes. Close the faucet.

\*Recommended by the Water Quality Association. On some water supplies, the unit may need periodic disinfecting.

## 13. RESTART THE WATER HEATER

- a. Turn on the electricity or fuel supply to the water heater and relight the pilot, if applicable.

**NOTE:** The water heater is filled with hard water and, as hot water is used, it refills with conditioned water. In a few days, the hot water will be fully conditioned. To have fully conditioned hot water immediately, wait until the initial recharge (previous step) is over. Then, drain the water heater (following instructions for water heater) until water runs cold.

# Programming the Electronic Controller

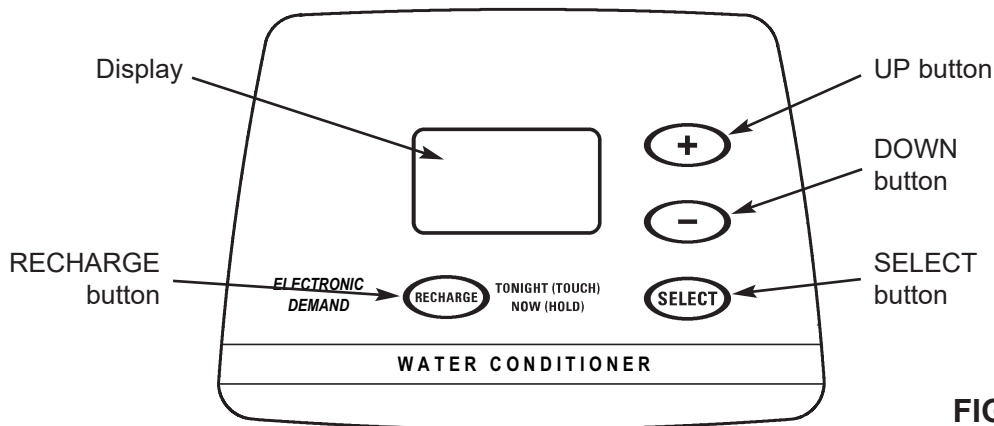

FIG. 16

## CONTROLLER SETTINGS REQUIRED

upon installation, and after an extended power outage.

When the power supply is plugged into the electrical outlet, a model code (E6130) and a test number (example: J2.0), are briefly shown in the display. Then the words "PRESENT TIME" appear and 12:00 PM begins to flash.

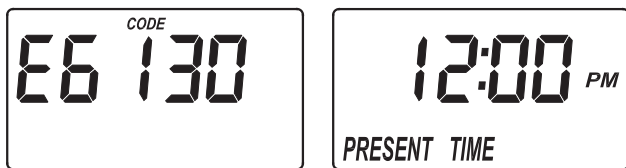

FIG. 17

## A. SET PRESENT TIME OF DAY

If the words "PRESENT TIME" do not show in the display, press the SELECT button several times until they do.

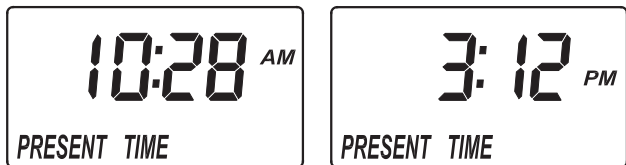

FIG. 18

1. Press the UP (+) or DOWN (-) buttons to set the present time. Up moves the display ahead; down sets the time back. Be sure AM or PM is correct.

**NOTE:** Press buttons and quickly release to slowly advance the display. Hold the buttons down for fast advance.

2. When the correct time is displayed, press the SELECT button, and the display will change to show the "Hardness" screen.

## B. SET WATER HARDNESS NUMBER

**NOTE:** If "HARDNESS" and a number do not show in the display, press the SELECT button a few times until they do.



FIG. 19

1. Press the UP (+) or DOWN (-) buttons to set the value of your water's hardness in grains per gallon (gpg).

**NOTE:** If your water supply contains iron, compensate for it by adding to the water hardness number. For example, assume your water is 20 gpg hard and contains 2 ppm iron. Add 5 to the hardness number for each 1 ppm of iron. In this example, you would use 30 for your hardness number.

$$\begin{array}{r}
 20 \text{ gpg hardness} \\
 2 \text{ ppm iron} \times 5 = 10 \text{ } +10 \\
 \text{(times)} \qquad \qquad \qquad 30 \text{ HARDNESS NUMBER}
 \end{array}$$

2. When finished setting your water's hardness number, press the SELECT button, and the display will change to show the "Recharge Time" screen.

continued on next page

# Programming the Electronic Controller

continued from previous page

## C. SET REGENERATION STARTING TIME

**NOTE:** If "RECHARGE TIME" and a flashing time (2:00 AM is the factory default) are not showing in the display, press the SELECT button a few times until they do.

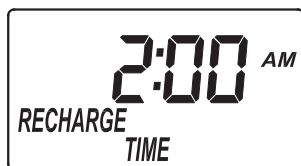

FIG. 20

1. Press the UP (+) or DOWN (-) buttons to set the desired regeneration start time in 1 hour increments. The factory default is 2:00 AM. In most households this is a good time for regeneration to start (takes about 2 hours) because water is not being used. During regeneration hard water is bypassed to house faucets.
2. When finished setting the desired regeneration start time, press the SELECT button. The display then shows the present time of day.

## NORMAL OPERATION

During normal operation, the present time of day shows in the display.

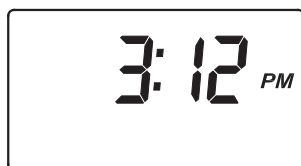

FIG. 21

## PROGRAM MEMORY

If electrical power to the softener is interrupted, the time display is blank, but the electronic controller keeps correct time for several hours. When power is restored, you must reset the present time only if the display is flashing. All other settings are maintained and never require resetting unless a change is desired. If the time is flashing after a long power outage, the softener continues to work as it should to provide you with soft water. However, regenerations may occur at the wrong time of day until you reset the clock to the correct time of day.

## OPTIONAL RECHARGE CONTROLS

Sometimes a manually initiated regeneration (recharge) may be desired or needed. Two examples:

- You have used more water than usual (guests, extra washing, etc.) and you may run out of soft water before the next scheduled regeneration.
- You did not refill the storage tank with salt before it had run completely out.

Use one of the following two features to begin a regeneration either immediately or at the next preset regeneration start time:

### RECHARGE NOW

To manually start a regeneration cycle, press and hold the RECHARGE button for a few seconds, until "RECHARGE NOW" flashes in the display.



FIG. 22

The softener begins an immediate regeneration. When completed (in about two hours), you will have a new supply of soft water. Once started, you cannot cancel this regeneration.

### RECHARGE TONIGHT

To set a regeneration cycle to begin at the next preset regeneration time, touch (press, but do not hold) the RECHARGE button. "RECHARGE TONIGHT" flashes in the display.

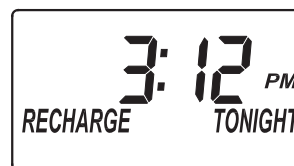

FIG. 23

A regeneration will begin at the next preset regeneration start time (2:00 AM or as set). If you decide to cancel this regeneration before it starts, touch the same button once more.

## VACATION NOTE

Demand controlled water softeners regenerate only while water is being used and softening capacity must be restored. For this reason, the unit will not regenerate when you are away from home for extended periods, unless you program the "Maximum Days Between Regenerations" feature (see next page)..

# Controller Features / Options

## OPTIONAL SETTINGS:

- SALT EFFICIENCY
- MAXIMUM DAYS BETWEEN REGENERATIONS
- 12 / 24 HOUR CLOCK

1. To set any of these options, press and hold SELECT for 3 seconds until "000 - -" shows in the display.



FIG. 24

Then press (do not hold) SELECT again to display one of the "Salt Efficiency" screens shown below.

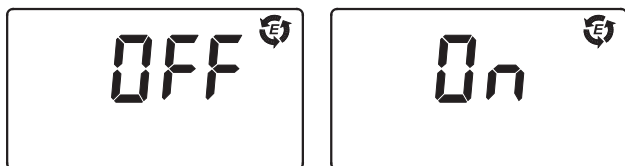

FIG. 25

**SALT EFFICIENCY:** When this feature is ON, the water softener will operate at salt efficiencies of 4000 grains of hardness per pound of salt or higher. The softener may recharge more often using smaller salt dosage and less water. This softener is shipped with the efficiency feature set OFF. Use the UP (+) or DOWN (-) buttons to change between OFF and ON. An efficiency icon will be displayed when this feature is ON.

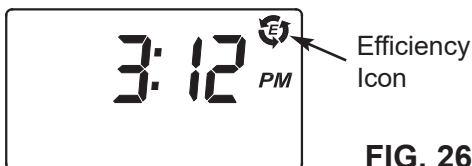

FIG. 26

2. Press SELECT again to display the "Recharge Days" screen.



FIG. 27

## MAXIMUM DAYS BETWEEN REGENERATIONS:

The electronic controller automatically determines regeneration frequency. This provides the greatest operating efficiency and, under most conditions this feature will be left in its default mode. However, you can set this feature to force a regeneration every set number of days. You may want to do this if, for example, your water supply contains iron and you want the softener to regenerate at least once every few days to keep the resin bed clean. Use the UP (+) or DOWN (-) to change the number of days (up to 15). If no change is desired, continue to next step.

3. Press SELECT again to display the "12 or 24 hr" screen.

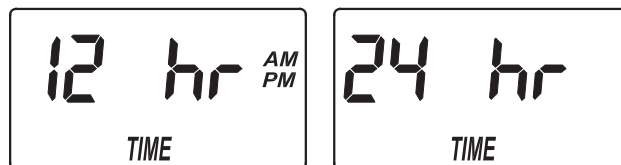



FIG. 28

**12 OR 24 HOUR CLOCK:** All time displays are shown in 12 hour (AM/PM) format at the default setting. If 24 hour time format is desired, set to "24 hr" by pressing the UP (+) button.

4. Press SELECT to return to the normal run (time of day) screen.

## CALIFORNIA EFFICIENCY REQUIREMENT

Your water softener has a "High Efficiency" feature with an ON or OFF setting. This softener setting is shipped in the OFF position, which utilizes the maximum rated capacity while most often achieving maximum salt efficiencies. When installing this unit in the State of California, you **MUST** turn this setting to the ON position, which may initiate more frequent recharges. However it will operate at 4000 grains per pound of salt or higher.

If you wish to turn the Salt Efficiency feature ON (  icon will show in the display), follow the instructions on this page.

# Water Softener Maintenance

## ADDING SALT

Brine (salt dissolved in water) is needed for every regeneration. The water for making brine is metered into the salt storage area by the softener valve and timer. If the water softener uses all the salt before more is added, hard water will result. Lift the brine tank lid and check the salt level every week. Be sure that the brinewell cover is on when adding salt.

**NOTE:** In humid areas it is best to keep the salt level less than half full and refill more often.

**RECOMMENDED SALT:** Cube, pellet, coarse solar, etc., water softener salt is recommended. This type of salt is high purity evaporated crystals, sometimes formed and pressed into briquets. It has less than 1% insoluble (not dissolvable in water) impurities. Clean, high grade rock salts are acceptable, but may require frequent brine tank cleaning to remove the "sludge" residue (insolubles) collecting at the bottom of the tank.

**SALT NOT RECOMMENDED:** Rock salt high in impurities, block, granulated, table, ice melting, or ice cream making salts, etc., are not recommended.

**SALT WITH IRON REMOVING ADDITIVE:** Some salts have an additive to help a water softener handle iron in the water supply. Although this may help keep the resin bed clean, it may also release corrosive fumes that will weaken and shorten the life of some water softener electronic parts.

## BREAKING A SALT BRIDGE

Sometimes a hard crust or salt "bridge" forms in the brine tank. This is usually caused by high humidity or the wrong kind of salt. When the salt bridges, an empty space forms between the water and the salt. Then salt will not dissolve in the water to make brine. Without brine, the resin bed is not recharged and hard water will result.

If the storage tank is full of salt, it is difficult to tell whether there is a salt bridge. A bridge may be underneath loose salt. The following is the best way to check for a salt bridge:

Salt should be loose all the way to the bottom of the tank. Hold a broom handle, or like tool, up to the softener, as shown in Figure 29. Make a pencil mark on the handle 1-2" below the top of the rim. Then, carefully push it straight down into the salt. If a hard object is felt before the pencil mark is even with the top, it is most likely a salt bridge. Carefully push into the bridge in several places to break it. **Do not try to break the salt bridge by pounding on the outside of the salt tank. You may damage the tank.**

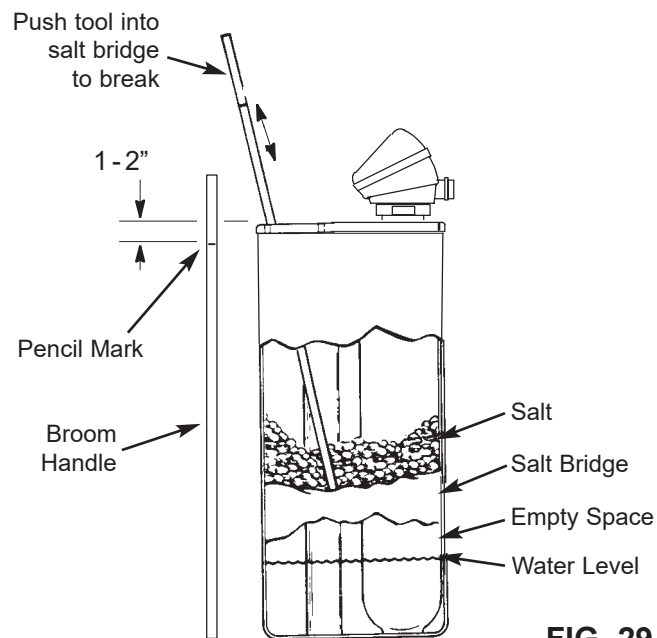

FIG. 29

# Water Softener Maintenance

## CLEANING THE NOZZLE & VENTURI

A clean nozzle & venturi (See Figure 30) is necessary for the water softener to work properly. This small unit creates the suction to move brine from the brine tank into the resin tank. If it should become plugged with dirt, silt, sand, etc., the water softener will not work and hard water will result.

To get access to the nozzle & venturi, remove the softener's top cover. Put the bypass valve(s) into the bypass position. Be sure the softener is in the service cycle (no water pressure at the nozzle & venturi). Then, holding the nozzle & venturi housing with one hand, turn the cap to remove it. Do not lose the o-ring seal. Lift out the screen support and screen. Then, remove the nozzle & venturi. Wash the parts in warm, soapy water and rinse in fresh water. If needed, use a small brush to remove iron or dirt. Be careful not to scratch, misshape, etc., surfaces of the nozzle & venturi. Also, check and clean the gasket and flow plug(s) if dirty.

Carefully replace all parts in the correct order. Lubricate the o-ring seal with silicone grease and put in place. Install and tighten the cap, by hand only. Do not overtighten, which could break the cap or housing. Put the bypass valve(s) into service (soft water) position.

## RESIN BED CLEANING

If the water supply contains clear water iron, regular resin bed cleaning is needed to keep the bed from coating with iron. Use resin bed cleaner, following directions on the container. Clean the resin every six months, or more often if iron appears in the conditioned water supply.

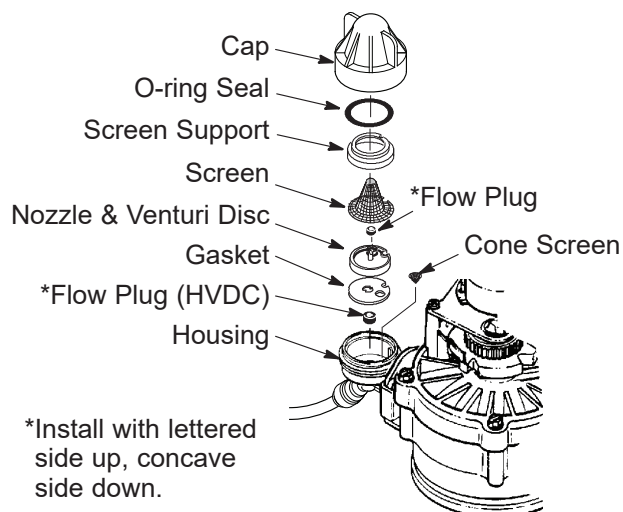

**IMPORTANT:** Be sure small hole in the gasket is centered directly over the small hole in the nozzle & venturi housing. Be sure the numbers are facing up

**FIG. 30**

# Troubleshooting Guide

PROBLEM	CAUSE	CORRECTION
<b>No soft water</b>	No salt in the storage tank.	Add salt and then initiate a "Recharge Now".
	Salt is "bridged" (a layer of salt in the salt storage tank has hardened).	Break salt bridge, as described on the previous page, and then initiate a "Recharge Now".
	If display is blank, power supply may be unplugged at wall outlet, power cable leads may be disconnected from the electronic control board, fuse may be blown, circuit breaker may be popped, or power supply may be plugged into a switched outlet which is "off."	Check for power loss due to any of these and correct. When power is restored, if the display shows the "Present Time" setting screen, it means time was lost during the outage. Set the present time. Other settings such as hardness are retained in memory during a power loss.
	Manual bypass valve(s) in bypass position.	Place bypass valve(s) in service position.
	Dirty, plugged or damaged nozzle & venturi.	Take apart, clean and inspect the nozzle & venturi assembly.
	Valve drain hose plugged or restricted.	Drain hose must not have any kinks, sharp bends, or be raised too high above the softener.
<b>Water hard sometimes</b>	Bypassed hard water being used during recharge, due to present time or recharge time settings being incorrect.	Check the time displayed. If not correct, refer to "Set Present Time of Day". Check the regeneration starting time.
	Hardness number setting is too low.	Referring to "Set Water Hardness Number", check the current hardness setting and increase if needed.
	Hot water being used when softener is recharging.	Avoid using hot water during recharges, because water heater refills with hard water.
	Increase in actual hardness of water supply.	Have unsoftened water sample tested. Check the current "Hardness" setting and increase if needed.
	Turbine is not turning freely.	Check turbine, as described on the next page.
<b>Motor stalled or clicking</b>	Motor malfunction or internal valve fault causing high torque on motor.	Contact your dealer for service.
<b>Error code Err01, Err02, Err03 or Err04 displayed.</b>	Fault in wiring harness, connections to position switch, switch, valve or motor.	Contact your dealer for service.
<b>Error code Err05 displayed.</b>	Electronic timer (PWA) malfunction.	Contact your dealer for service.

## TROUBLESHOOTING - INITIAL CHECKS

### Always make these initial checks first:

1. Is display blank? Check power source.
2. Is Error code displayed? If so, go to "Automatic Electronic Diagnostics."
3. Is correct time displayed? If not, recharges occur at the wrong time. Set present time.
4. Is there salt in the brine tank? If not, refill.
5. Is salt "bridged"?
6. Are plumbing bypass valve(s) in service position?
7. Are inlet and outlet pipes connected to the water softener inlet and outlet respectively?
8. Is valve drain hose free of kinks and sharp bends, and not elevated over 8 feet above the floor.
9. Is the brine tube connected?
10. Check the hardness setting (See "Set Water Hardness Number"). Be sure it is correct for the household's water supply. Perform a hardness test on a raw water sample to compare with the setting.
11. Perform a hardness test on a conditioned water sample to determine whether a problem exists.

If no problem is found after making the initial checks, proceed to "Troubleshooting - Manual Diagnostics" and "Manual Advance Recharge Check" on the next three pages.

# Troubleshooting

## AUTOMATIC ELECTRONIC DIAGNOSTICS

The electronic controller has a self-diagnostic function for the electrical system (except input power and water meter). The computer monitors the electronic components and circuits for correct operation. If a malfunction occurs, an error code appears in the display.

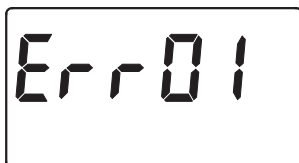

FIG. 31

The chart on the previous page shows the error codes that could appear, and possible problems indicated by the codes. While an error code is displayed, all timer buttons are inoperable, except for the SELECT button. SELECT remains operational so the service person can make use of the Manually Initiated Electronic Diagnostics to further isolate the defect, and check the water meter.

### TO REMOVE AN ERROR CODE:

1. Unplug the power supply.
2. Correct the problem.
3. Plug the power supply back in.
4. Wait for at least 8 minutes while the electronic controller operates the valve through an entire cycle. The error code will return if the problem was not corrected.

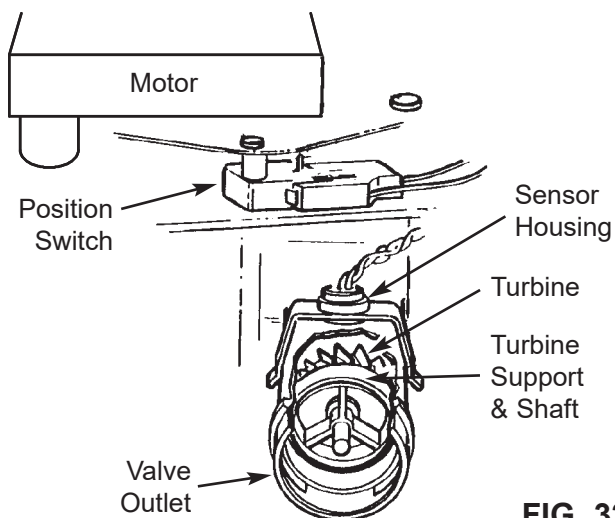

FIG. 32

## MANUALLY INITIATED ELECTRONIC DIAGNOSTICS

1. To enter diagnostics, press and hold the SELECT button until "000 - -" appears in the display.



FIG. 33

2. The first 3 digits indicate water meter operation as follows:

000 (steady) = Soft water not in use, and no flow through the meter.

OPEN A NEARBY SOFT WATER FAUCET.

000 to 199 (continual) = Repeats for each gallon of water passing through the meter.

- NOTE:** If you don't get a reading in the display with faucet open, pull the sensor from the valve outlet port. Pass a small magnet back and forth in front of the sensor. If you get a reading in the display with the magnet, unhook the in and out plumbing and check the turbine for binding (See Figure 32).

3. The last 2 digits in the display indicate position switch operation as follows:

Correct Switch Displays	Valve Cycle Status
- -	Valve in service, fill, brining, backwash or fast rinse position.
- P	Valve rotating from one position to another.

4. Use the RECHARGE button to manually advance the valve into each cycle and check correct switch operation.
5. While in this diagnostic screen, the following information is available and may be beneficial for various reasons. This information is retained by the computer from the first time electrical power is applied to the electronic controller.
  - a. Press the UP (+) button to display the number of days this electronic control has had electrical power applied.
  - b. Press the DOWN (-) button to display the number of regenerations initiated by this electronic control since the model code number was entered.

continued on next page

# Troubleshooting

continued from previous page

6. Press the SELECT button and hold in for 3 seconds until the model code (E6130) shows in the display. This code identifies the softener model. If the wrong number shows, the softener will operate on incorrect configuration data.
7. To change the code number - Press UP (+) or DOWN (-) button until the correct code shows.
8. To return to the present time display, press the SELECT button. **If the model code was changed, make all electronic controller settings.**

**NOTE:** If the electronic control is left in a diagnostic display (or a flashing display when setting times or hardness), present time automatically returns if a button is not pressed within 4 minutes.

## RESETTING TO FACTORY DEFAULTS

To reset the electronic controller to its factory default for all settings (time, hardness, etc.):

1. Press the SELECT button and hold it until the display changes twice to show "CODE" and the flashing model code.
2. Press the UP (+) button (a few times, if necessary) to display a flashing "SoS".

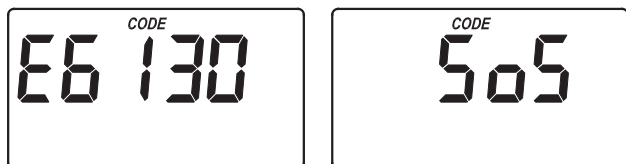

FIG. 34

3. Press the SELECT button, and the electronic controller will restart.
4. Set the present time, hardness, etc., as described on pages 11 & 12.

## MANUAL ADVANCE REGENERATION CHECK

This check verifies proper operation of the valve motor, brine tank fill, brine draw, regeneration flow rates, and other controller functions. Always make the initial checks, and the manual initiated diagnostics.

**NOTE:** The electronic control display must show a steady time (not flashing).

1. Press the RECHARGE button and hold in for 3 seconds. "RECHARGE NOW" begins to flash as the softener enters the fill cycle of regeneration. Remove the brinewell cover and, using a flashlight, observe fill water entering the tank.

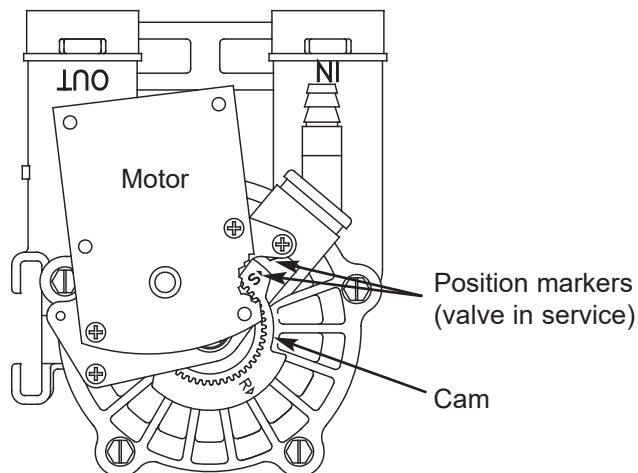

FIG. 35

If water does not enter the tank, look for an obstructed nozzle, venturi, fill flow plug, brine tubing, or brine valve riser pipe.

2. After observing fill, press the RECHARGE button to move the softener into brining. A slow flow of water to the drain will begin. Verify brine draw from the brine tank by shining a flashlight into the brinewell and observing a noticeable drop in the liquid level.

**NOTE:** Be sure water is in contact with the salt, and not separated by a salt bridge.

If the water softener does not draw brine, check for (most likely to least likely):

- Dirty or plugged nozzle and venturi.
- Nozzle and venturi not seated on the gasket, or gasket deformed.
- Restriction in valve drain, causing a back-pressure (bends, kinks, elevated too high, etc.).
- Obstruction in brine valve or brine tubing
- Inner valve failure (obstructed outlet disc, wave washer deformed, etc.)

**NOTE:** If water system pressure is low, an elevated drain hose may cause back pressure, stopping brine draw.

3. Again, press the RECHARGE button to move the softener into backwash. Look for a fast flow of water from the drain hose.  
An obstructed flow indicates a plugged top distributor, backwash flow plug, or drain hose.
4. Press the RECHARGE button to move the softener into fast rinse. Again look for a fast drain flow. Allow the softener to rinse for a few minutes to flush out any brine that may remain in the resin tank from the brining cycle test.
5. To return the softener to service, press the RECHARGE button.

# Wiring Schematic

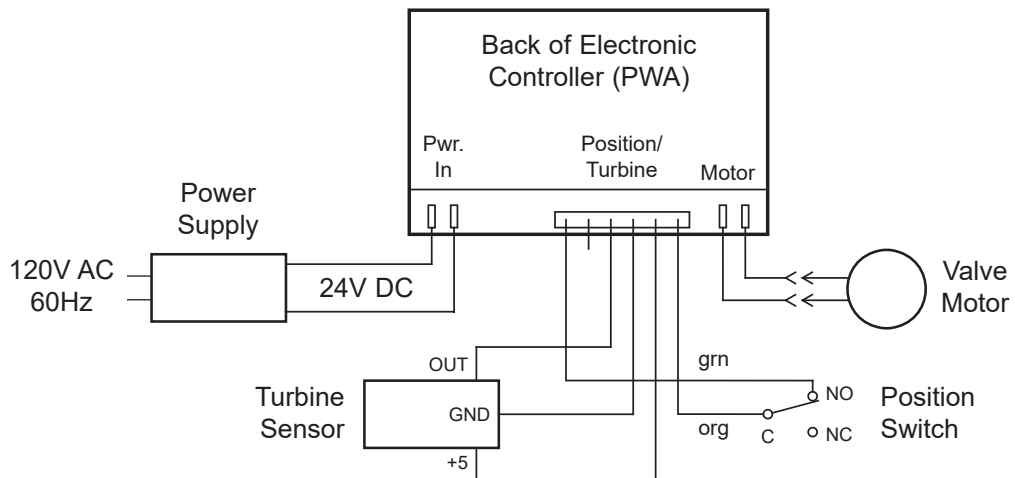
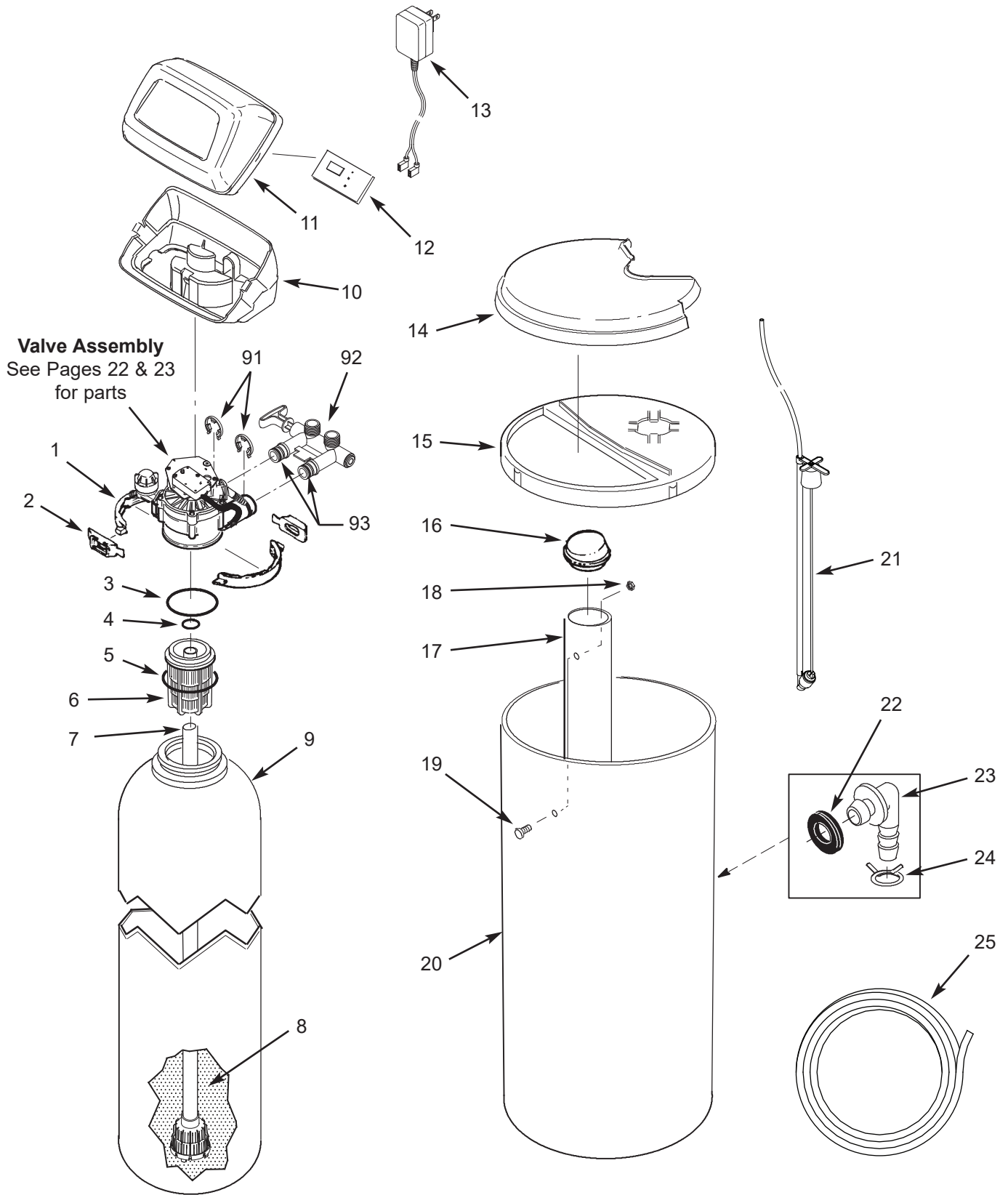

FIG. 36

# Water Softener Exploded View



# Water Softener Parts List

Key No.	Part No.	Description
–	7331177	Tank Neck Clamp Kit (includes Key Nos. 1 & 2)
1	↑	Clamp Section (2 req.)
2	↑	Retainer Clip (2 req.)
–	7112963	Distributor O-Ring Kit (includes Key Nos. 3-5)
3	↑	O-Ring, 2-7/8" x 3-1/4"
4	↑	O-Ring, 13/16" x 1-1/16"
5	↑	O-Ring, 2-3/4" x 3"
6	7077870	Top Distributor
7	7105047	Repl. Bottom Distributor
8	0502272	Resin, 1 cu. ft.
9	7113058	Repl. Resin Tank, 8" x 40"
10	7180314	Bottom Cover
11	7180291	Faceplate Cover (also order following decal)
■	7328661	Faceplate Decal
12	7303213	Repl. Electronic Control Board (PWA)

Key No.	Part No.	Description
13	7351054	Power Supply, 24V DC
14	7192785	Salt Cover
15	7178626	Rim
16	7155115	Cover, Brinewell
17	7109871	Brinewell
–	7331648	Brinewell Mounting Hardware Kit (includes Key Nos. 18 & 19)
18	↑	Wing Nut, 1/4-20
19	↑	Screw, 1/4-20 x 5/8"
20	7161831	Repl. Brine Tank
21	7381172	Brine Valve Assembly
–	7331258	Overflow Hose Adaptor Kit (includes Key Nos. 22-24)
22	↑	Grommet
23	↑	Adaptor Elbow
24	↑	Hose Clamp
25	7139999	Drain Hose

■ Not illustrated.

Manufactured and warranted by  
Water Channel Partners  
2805 Dodd Road, Suite 300  
Eagan, MN 55121

# Valve Exploded View

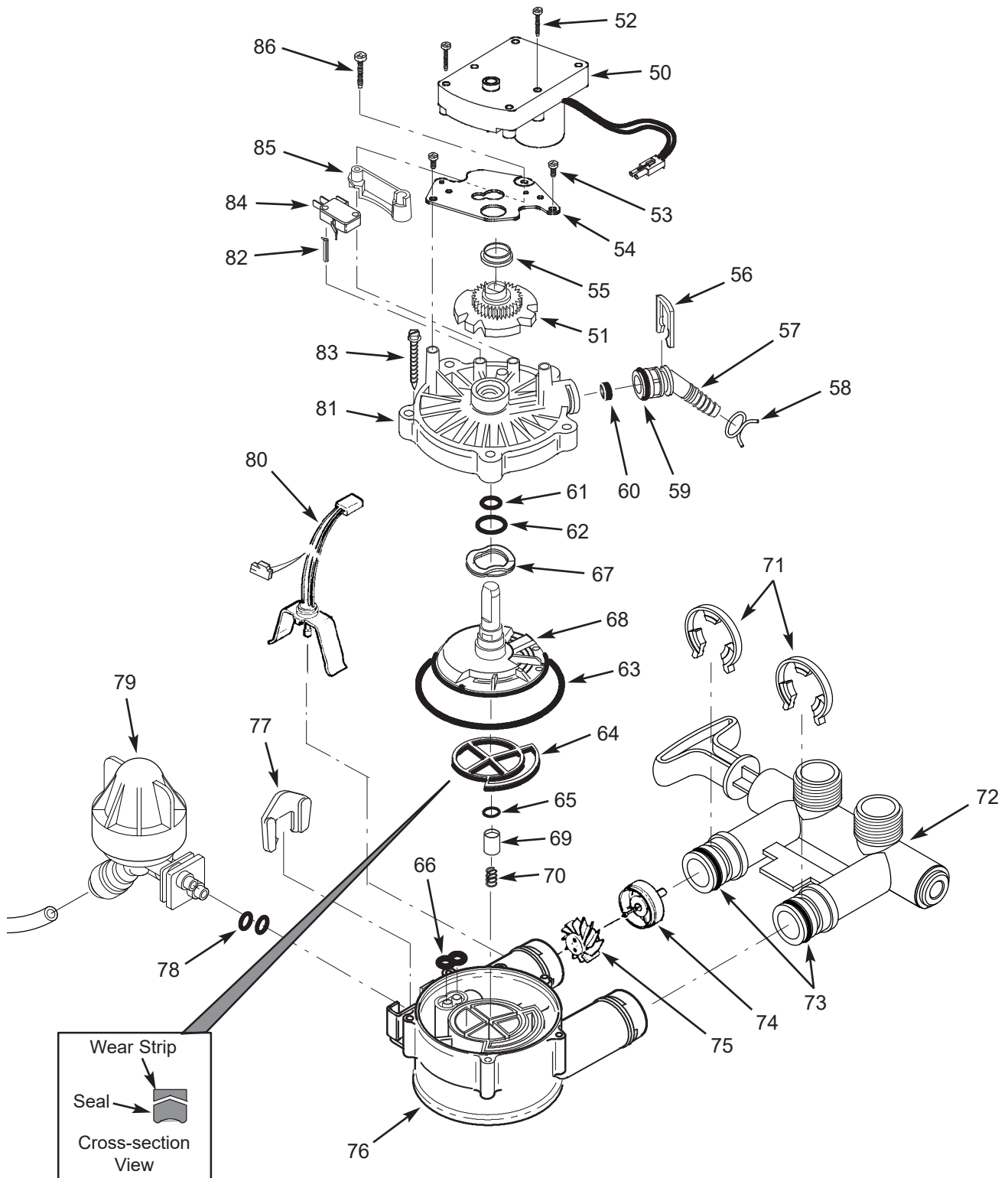

# Valve Parts List

Key No.	Part No.	Description
-	7397864	Motor, Cam & Gear Kit, 3/4" (includes Key Nos. 50-52)
50	↑	Motor
51	↑	Cam & Gear
52	7224087	Screw, #8-32 x 1" (2 req.)
53	0900857	Screw, #6-20 x 3/8" (2 req.)
54	7308085	Motor Plate
55	0503288	Bearing
-	7331185	Drain Hose Adaptor Kit (includes Key Nos. 56-60)
56	↑	Clip, Drain
57	↑	Drain Hose Adaptor
58	↑	Hose Clamp
59	↑	O-Ring, 5/8" x 13/16"
60	↑	Flow Plug, 2.0 gpm
-	7129716	Seal Kit (includes Key Nos. 61-66)
61	↑	O-Ring, 7/16" x 5/8"
62	↑	O-Ring, 3/4" x 15/16"
63	↑	O-Ring, 3-3/8" x 3-5/8"
64	↑	Rotor Seal
65	↑	O-Ring, 3/8" x 9/16"
66	↑	Seal, Nozzle & Venturi
67	7082087	Wave Washer
68	7199232	Rotor & Disc

Key No.	Part No.	Description
-	7342665	Drain Plug Kit, 3/4" (includes Key Nos. 65, 69 & 70)
69	↑	Plug, Drain Seal
70	↑	Spring
71	7116713	Clip, 3/4", single (4 req.)
	7336397	Clip, 3/4", pack of 20
72	7370286	Bypass Valve Assembly, 3/4", in- cluding 2 O-Rings (See Key No. 73)
73	7170288	O-Ring, 15/16" x 1-3/16", single (2 req.)
	7336402	O-Ring, 15/16" x 1-3/16", pack of 20
-	7113040	Turbine & Support Assembly, including 2 O-Rings (See Key No. 73) & 1 ea. of Key Nos. 74 & 75
74	↑	Turbine Support & Shaft
75	↑	Turbine
76	7082053	Valve Body
77	7081201	Retainer, Nozzle & Venturi
78	7342649	O-Ring, 1/4" x 3/8", pack of 2
79	7398674	Nozzle & Venturi Kit (includes Key Nos. 77 & 78)
80	7309803	Wire Harness, Sensor
-	7331266	Valve Cover Assembly (includes Key Nos. 81 & 82)
81	↑	Valve Cover
82	↑	Expansion Pin
83	7342657	Screw, #10-14 x 2", pack of 5
84	7030713	Switch
85	7325702	Spacer, Motor Mount
86	7070412	Screw, #4-24 x 1-1/8", flat head

Manufactured and warranted by  
Water Channel Partners  
2805 Dodd Road, Suite 300  
Eagan, MN 55121