

# OWNER'S MANUAL

How to install, operate  
and maintain your

## Model **IDP12F** Multipurpose Water Filter

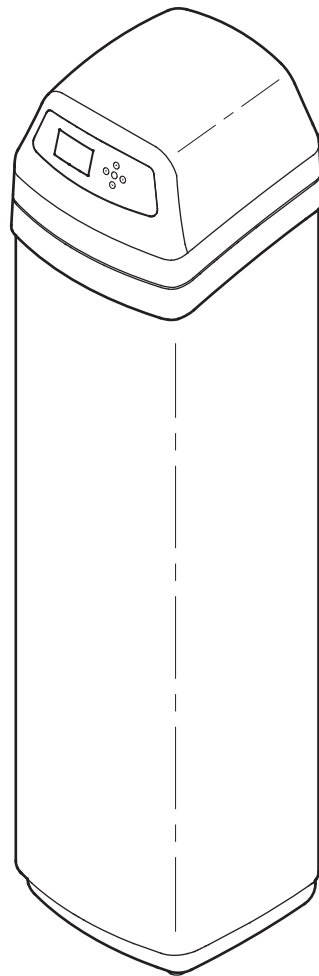

System tested and certified by the  
Water Quality Association against CSA B483.1,  
NSF/ANSI/CAN Standard 61, and NSF/ANSI/CAN  
Standard 372 for low lead content.



Designed, Engineered &  
Assembled in the U.S.A.

Manufactured by  
Water Channel Partners  
2805 Dodd Road, Suite 300  
Eagan, MN 55121

7371054 (Rev. M 1/7/26)

---

# Table of Contents & Safety Guides

## TABLE OF CONTENTS

	<u>Page</u>
Specifications & Dimensions .....	3
Before Starting Installation .....	4
Media Loading .....	5
Typical Installation Illustrations .....	6
Installation .....	7-8
General Information .....	9
Sanitizing Procedure .....	9
Setup Procedure .....	10
Programming the Water Filter .....	11-22
Service Information .....	23-24
Troubleshooting .....	25-28
Troubleshooting Guide .....	25
Wiring Schematic .....	25
Repair Parts .....	29-31
Warranty .....	32

## SAFETY GUIDES

Follow the installation instructions carefully. Failure to install the water filtration system properly **voids the warranty**.

Before you begin installation, read this entire manual. Then, obtain all the materials and tools you will need to make the installation.

**Check local plumbing and electrical codes.** The installation must conform to them.

**Use only lead-free solder and flux** for all sweat-solder connections, as required by state and federal codes.

Use care when handling the water filtration system. Do not turn upside down, drop, or set on sharp protrusions.

Do not locate the water filtration system where freezing temperatures occur. Do not attempt to treat water over 120°F. **Freezing, or hot water damage voids the warranty.**

Avoid installing in direct sunlight. Excessive sun heat may cause distortion or other damage to non-metallic parts.

The water filtration system requires a minimum water pressure of 30 psi at the inlet. **Maximum allowable inlet water pressure is 100 psi.** If daytime pressure is over 80 psi, nighttime pressure may exceed the maximum. Use a pressure reducing valve if necessary (Adding a pressure reducing valve may reduce the flow).

The water filtration system works on **24V DC** electrical power, supplied by a direct plug-in power supply (included). Be sure to use the included power supply, and plug it into a nominal **120V, 60 Hz** household outlet that is in a **dry location only**, grounded and properly protected by an overcurrent device such as circuit breaker or fuse.

This system is not intended to be used for treating water that is microbiologically unsafe or of unknown quality without adequate disinfection before or after the system.



European Directive 2002/96/EC requires all electrical and electronic equipment to be disposed of according to Waste Electrical and Electronic Equipment (WEEE) requirements. This directive or similar laws are in place nationally and can vary from region to region. Please refer to your state and local laws for proper disposal of the equipment.

# Specifications & Dimensions

SPECIFICATIONS		
<b>Model</b>		<b>IDP12F</b>
Model Code		ID12F
Nominal Resin Tank Size		12" Dia. x 54"
Sediment Removal (Filter Aggregate)	limits:	factory recommendation based on water analysis
Acid Neutralizer (Neutralite)	water supply limits:	pH 6.0 - 6.8
Taste & Odor Removal (Activated Carbon)	limits:	factory recommendation based on water analysis
Recommended Amount of Mineral *		2 cu. ft.
Recommended Amount of Filter Sand *		14 - 15 lb.
Amount of Gravel		29 lb.
Min. - Max. Water Supply Pressure		20 - 100 psi
Min. - Max. Water Supply Temperature		40 - 120 °F (4 - 49 °C)
Minimum Inlet Water Flow, Backwash & Fast Rinse Flow to Drain		3 - 10 gal. / min. depending on media used
Default Backwash Time		25 minutes
Default Fast Rinse Time		5 minutes

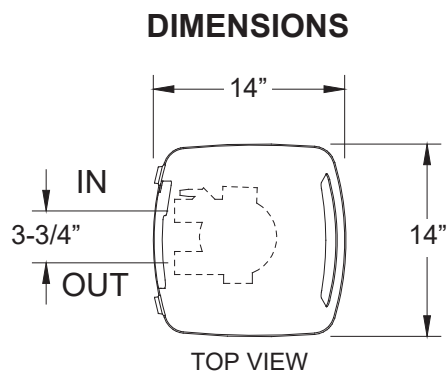

\* Not included with the filter.

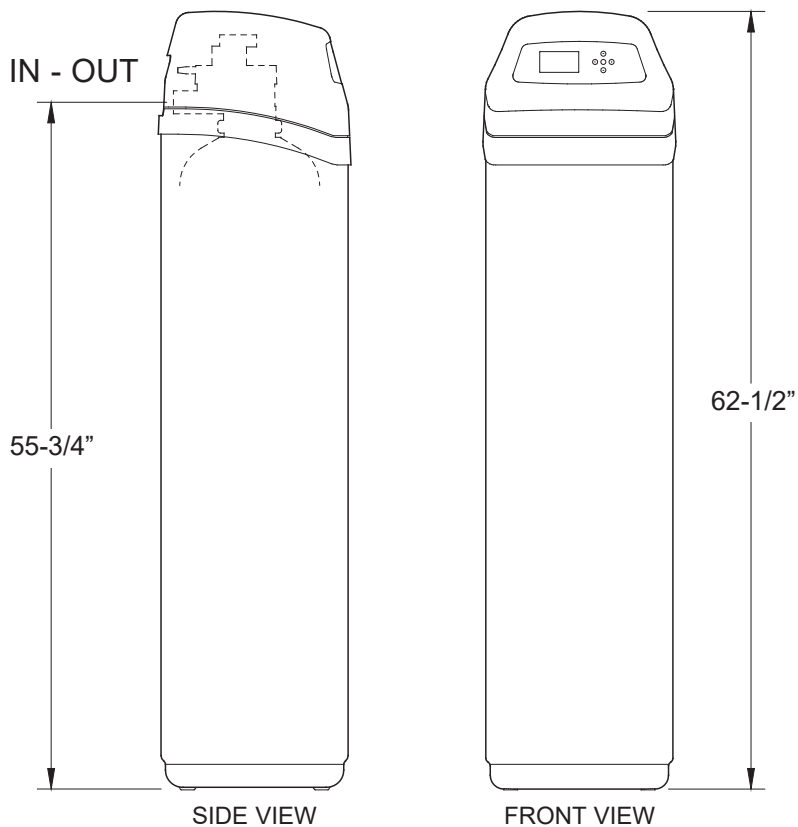

**FIG. 1**

# Before Starting Installation

## UNPACKING

Model IDP12F Multipurpose Water Filter is shipped from the factory in one master carton. The carton also includes a bag of small parts needed to assemble and install the unit, plus this manual.

**NOTE: Filtering mineral is not included.** See Page 33 for ordering information.

Thoroughly check the filter for possible shipping damage and parts loss. Also inspect and note any damage to the shipping carton. Notify the transportation company if damage is present. Manufacturer is not responsible for in-transit damages.

Remove and discard (or recycle) all packing materials. We suggest you keep the small parts in the bag(s) until you are ready to use them.

## WHERE TO INSTALL THE FILTER

- Place the filter as close as possible to the pressure tank (well system) or water meter (city water).
- Place the filter as close as possible to a floor drain, or other acceptable drain point (laundry tub, sump, standpipe, etc.). **CAUTION:** Drain water exits the hose at a fast flow rate, and at water system pressure. Be sure the hose is fastened in some manner to prevent "whipping" and splashing to prevent water damage to surrounding area.
- Connect the filter to the main water supply pipe **UPSTREAM** OF the water heater. **DO NOT RUN HOT WATER THROUGH THE FILTER.** The temperature of water passing through the filter must be less than 120°F.
- Keep outside faucets on unfiltered water to conserve filtering capacity.
- Do not install the filter in a place where it could freeze. Damage caused by freezing is not covered by the warranty.
- Put the filter in a place water damage is least likely to occur if a leak develops. The manufacturer will not repair or pay for water damage.
- A 120V, 60 Hz electrical outlet, to plug the included power supply into, is needed near the filter. Be

sure the electrical outlet and power supply are in an inside location, to protect from wet weather.

- If installing in an outside location, you must take the steps necessary to assure the filter, installation plumbing, wiring, etc., are as well protected from the elements, contamination, vandalism, etc., as when installed indoors.
- Keep the filter out of direct sunlight. The sun's heat may soften and distort plastic parts.

## TOOLS, PIPE & FITTINGS, OTHER MATERIALS YOU WILL NEED

- Plastic inlet and outlet fittings included with the filter allow water flow equivalent to 1 inch nominal pipe. To maintain full valve flow, 1" pipes to and from the filter fittings are recommended. Do not reduce the pipes to less than 3/4" size.
- Use copper, brass or PEX plastic pipe and fittings.
- **ALWAYS** install a single bypass valve, or 3-valve bypass system. Bypass valves let you turn off water to the filter for repairs if needed, but still have water available to the house pipes.
- Drain hose 5/8" inside diameter minimum, with a garden hose connection on one end, is needed for the valve drain. See step 5 on page 8.
- If a rigid valve drain is needed, to comply with plumbing codes, you can buy the parts needed (see page 6) to connect a 5/8" minimum copper tubing drain.

## PLAN HOW YOU WILL INSTALL THE FILTER

You must first decide how to run in and out pipes to the filter. Look at the house main water pipe at the point where you will connect the filter. Is the pipe soldered copper, glued plastic, or threaded brass/galvanized? What is the pipe size?

Now look at the typical installation illustration on page 6. Use it as a guide when planning your particular installation. Be sure to direct incoming, unfiltered water to the filter valve inlet fitting. The valve ports are marked IN and OUT.

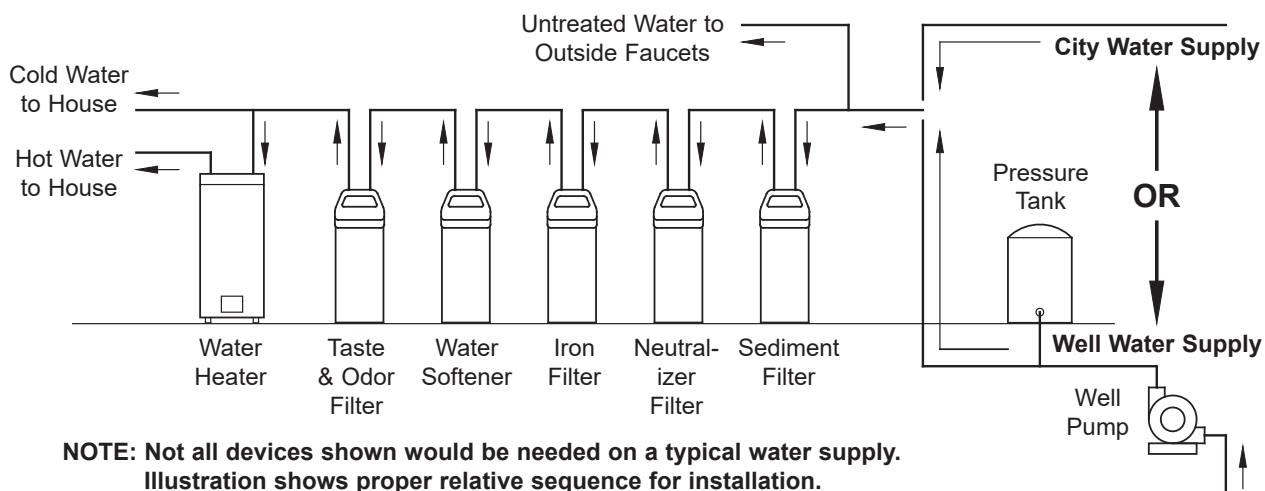

FIG. 2

# Media Loading

## MEDIA LOADING

Model IDP12F Multipurpose Water Filter, as manufactured, has no media other than 29 pounds of quartz gravel at the bottom of the tank. Before plumbing the unit, load filter sand and mineral (See table on Page 3 for amounts):

1. Move the filter into installation location and set it on a flat, level surface.
2. Take off the unit's top cover and unplug the wiring connections between the valve and the control board (PWA).
3. Remove retainer clips and clamp sections from the tank neck and carefully lift the valve off the tank.
4. Check the height of the riser pipe as shown in Figure 3. If riser pipe is more than 1/2" above the top distributor, make sure that bottom distributor is below gravel at the bottom of the tank. It may be necessary to lay the filter on its side to move gravel to one side, hold the bottom distributor at the bottom center of the tank and stand the unit back up. Level gravel after checking.
5. After confirming the riser pipe height, remove the top distributor from the tank neck, leaving the bottom distributor (including riser pipe) in place, centered in the tank.
6. Cover the top end of the riser pipe with a clean rag, to keep media out (See Fig. 4).
7. Using a larger neck funnel, add the recommended amounts of filter sand and mineral in that order (See Page 3). Use water sparingly to speed flow through the funnel (It may become necessary to siphon water from the bottom of distributor if tank becomes full of water).
8. Flush the tank opening with water to clean media particles from the top of the tank. Uncover the bottom distributor stand tube.
9. Finish filling the tank with water, up to the top of the tank.

**IMPORTANT:** Be sure to fill with water. This will eliminate air space, wet the media and prevent excessive air-head pressure when filter is pressurized.

10. Install the o-ring seals and top distributor exactly as shown in Figure 5. Place the small o-ring at the top of the riser pipe, where shown in Figure 3. If the o-rings need lubrication, use a high quality silicone grease.
11. Lower the valve assembly onto the tank, centering over the riser tube. Push downward, against the o-ring, and install the clamp sections, securing with the retainer clips.
12. Reconnect the wiring between the valve and the control board (PWA).
13. Verify that the drain flow plug (See Key No. 59 on Page 31) is appropriately sized for the media used. If necessary, install a different flow plug.

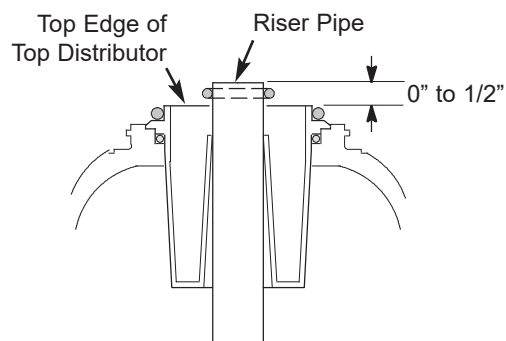

**Note:** Resin tank height can vary somewhat within manufacturing tolerance. So that the bottom distributor riser pipe has proper clearance with inside valve porting, check for the correct length, as shown above. Cut the riser pipe if needed to adjust the length. Be sure to remove burrs and sharp edges.

FIG. 3

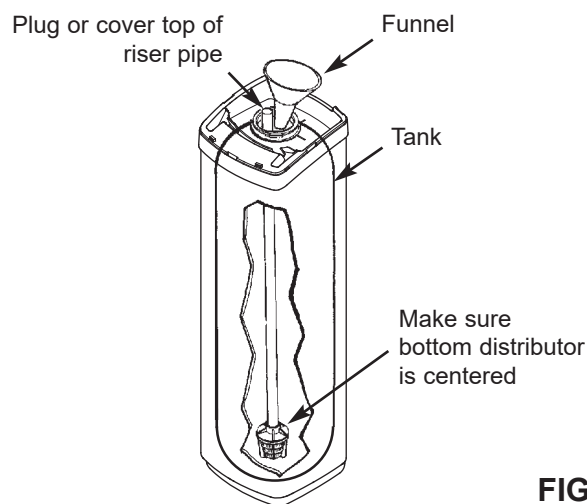

FIG. 4

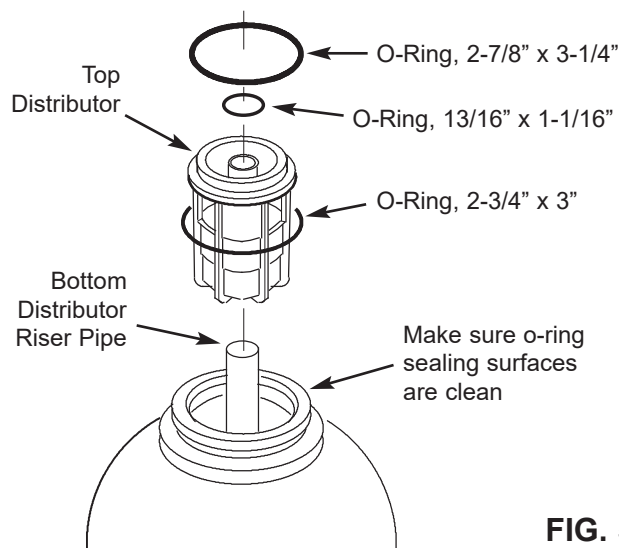

FIG. 5

# Typical Installation Illustrations

## INSTALLATION USING SINGLE BYPASS VALVE

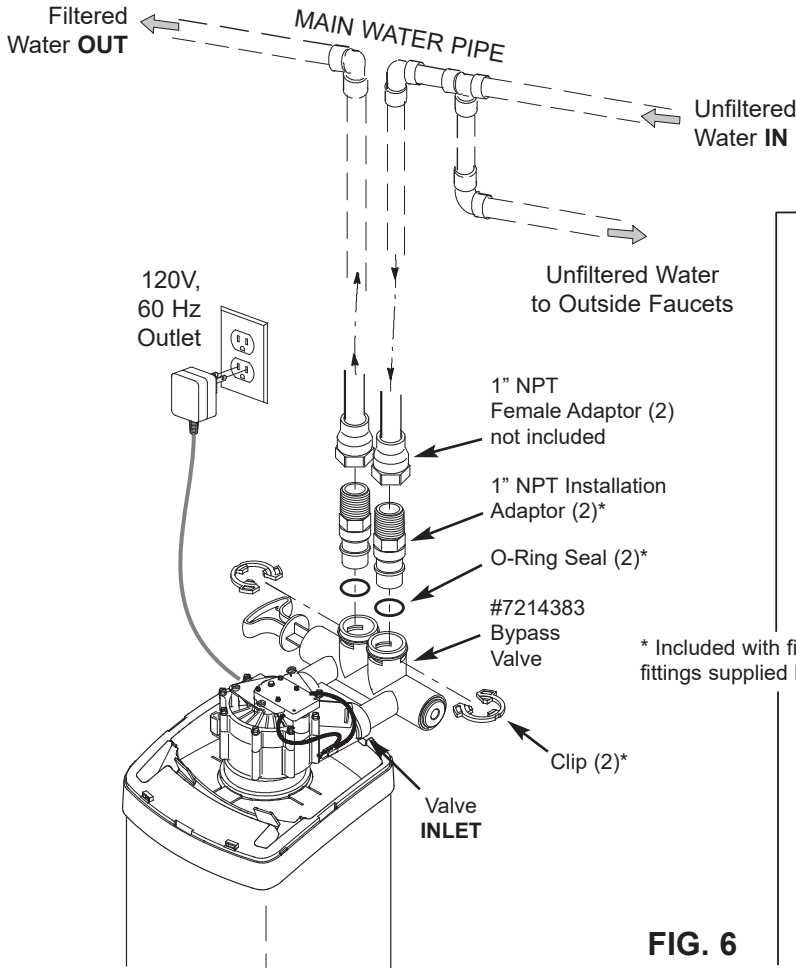
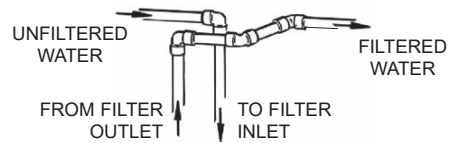

FIG. 6

## CROSS-OVER

Use if water supply flows from the left. Include single or 3-valve bypass.



## INSTALLATION USING 3-VALVE BYPASS

For filtered water SERVICE:

- Open the inlet and outlet valves

For unfiltered BYPASS:

- Close the inlet and outlet valves
- Open the bypass valve

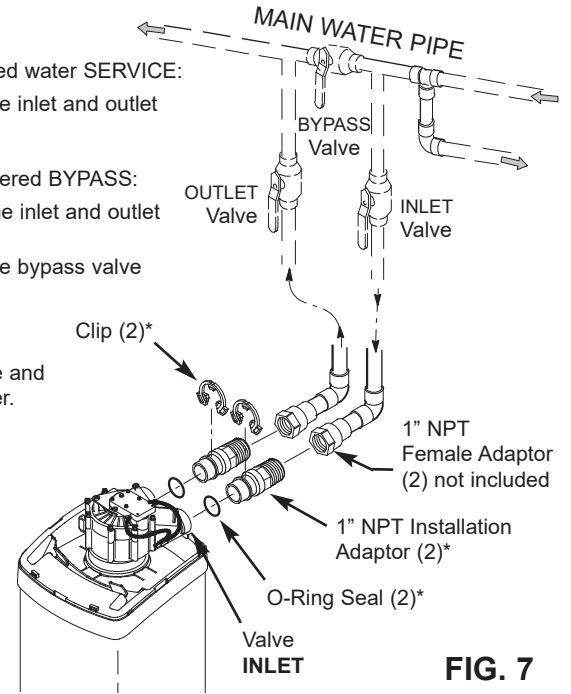
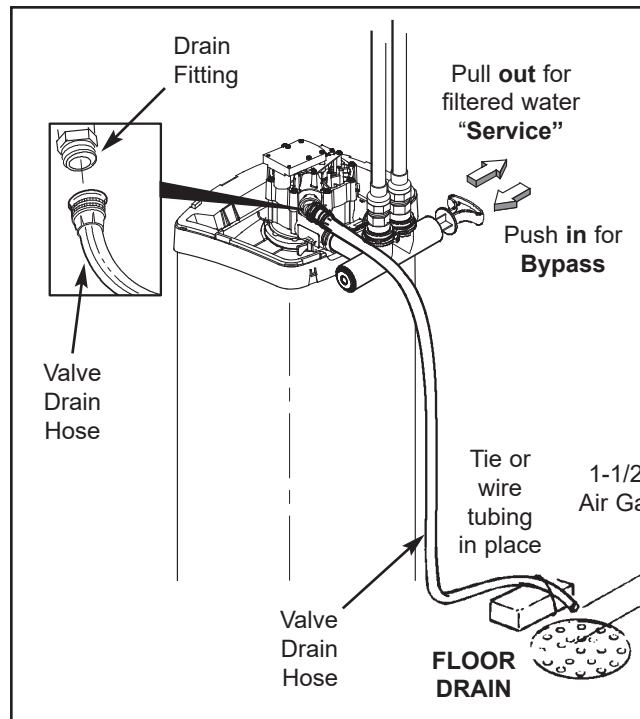
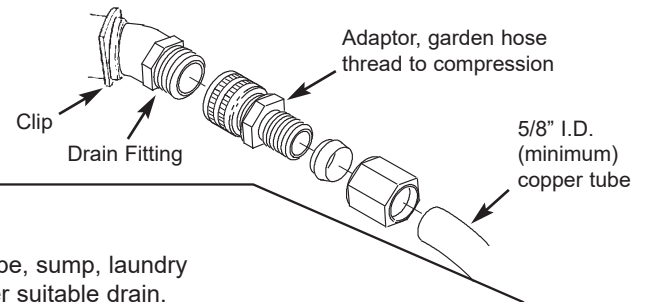

FIG. 7



## CONNECTING A RIGID VALVE DRAIN TUBE

To adapt a copper tube to the filter, buy a compression fitting (garden hose thread to 5/8" I.D. minimum tube and necessary tubing from your local hardware store.



To standpipe, sump, laundry tub or other suitable drain.

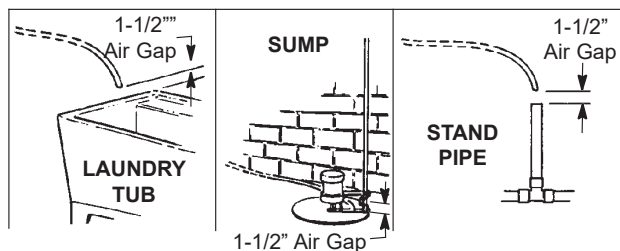

FIG. 8

# Installation

## 1. TURN OFF WATER SUPPLY

- Close the main water supply valve near the well pump or water meter.
- Shut off the electric or fuel supply to the water heater.
- Open high and low faucets to drain all water from the house pipes.

## 2. INSTALL BYPASS VALVE AND/OR PLASTIC ADAPTORS:

- If installing a single bypass valve, push the bypass valve, with lubricated o-ring seals in place, into the valve inlet and outlet ports (See Figures 6 & 9).
- OR -
- If installing a 3-valve bypass system, slide plastic installation adaptors, with lubricated o-ring seals in place, into the valve inlet and outlet ports (See Figure 7 & 9).
- Be sure the turbine support is in place in the valve outlet, as shown in Figure 10.
- Snap the two large plastic clips in place on the inlet and outlet ports, from the top, down (See Figure 11). Be sure they snap into place. Pull on the bypass valve or plastic adaptors, to make sure they are held securely in place.

## 3. COMPLETE PLUMBING TO AND FROM THE FILTER

Using the "Typical Installation Illustration" on page 6 as a guide, observe all of the following cautions while you connect inlet and outlet plumbing:

- Be sure incoming, **hard water** is directed to the valve **INLET** port.
- Be sure to install bypass valve(s).
- If making a soldered copper installation, do all sweat soldering before connecting pipes to the filter fittings. Torch heat will damage plastic parts.
- Use pipe joint compound on all external pipe threads.
- When turning threaded pipe fittings onto plastic fittings, use care not to cross-thread.
- Support inlet and outlet plumbing in some manner (use pipe hangers) to keep the weight off of the valve fittings.

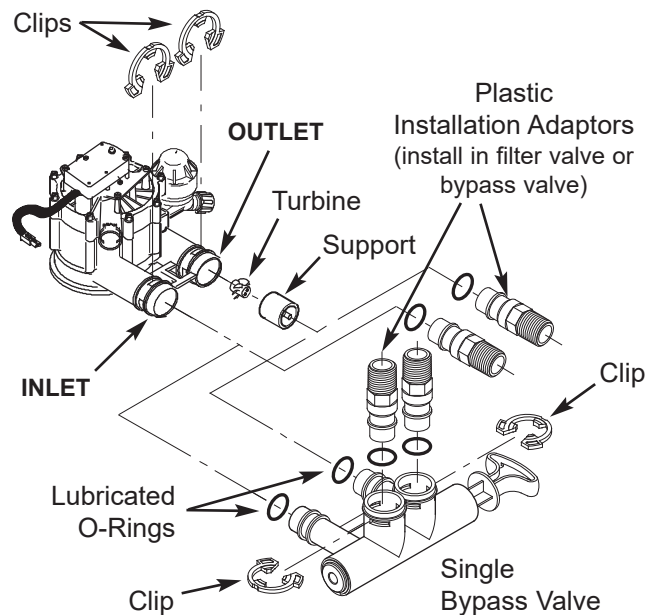

FIG. 9

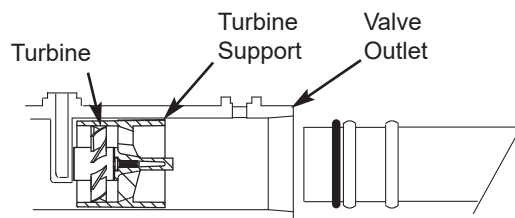

FIG. 10

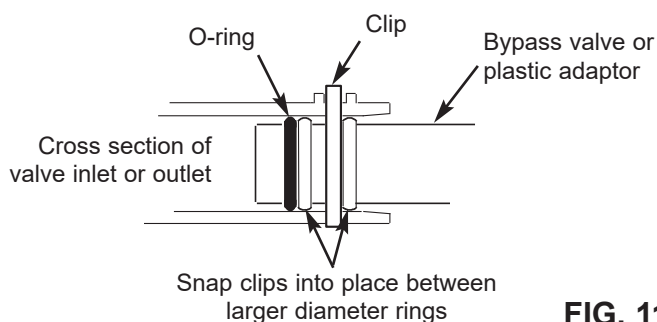
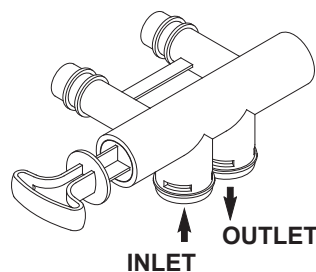

FIG. 11



Turn the bypass valve downward if connecting to floor level plumbing

FIG. 12

# Installation

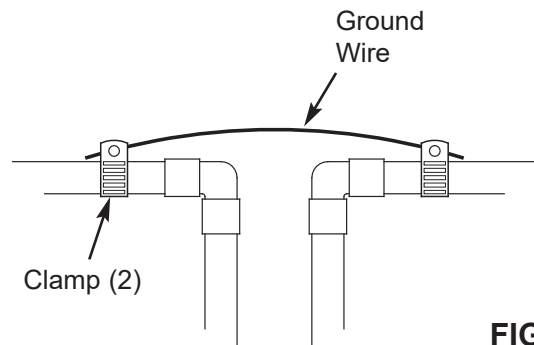

FIG. 13

## 4. COLD WATER PIPE GROUNDING

The house cold water pipe (metal only) is often used as a ground for the house electrical system. The 3-valve bypass type of installation, shown in Figure 7, will maintain ground continuity. If you use the plastic bypass, continuity is broken. To restore the ground, do the following:

- Install a #4 copper wire across the removed section of main water pipe, securely clamping at both ends (See Figure 13). Parts not included.

## 5. INSTALL VALVE DRAIN HOSE

- Take a length of 5/8" inside diameter garden hose and attach to the valve drain fitting (See Figure 8 on page 6).
- Locate the other end of the hose at a suitable drain point (floor drain, sump, laundry tub, etc.). Check and comply with local codes. Refer to Figure 8 on page 6 if codes require a rigid pipe drain run.

**IMPORTANT:** Use high quality, thick wall hose that will not easily kink or collapse. The filter will not backwash properly if water cannot exit this hose during recharges.

- Tie or wire the hose in place at the drain point. Water pressure will cause it to whip during the backwash portion of the recharge cycle. Also provide an air gap of at least 1-1/2" between the end of the hose and the drain point. An air gap prevents possible siphoning of sewer water, into the filter, if the sewer should back up.
- If raising the drain hose overhead is required to get to the drain point, do not raise higher than 8 feet above the floor. Elevating the hose may cause a back pressure that could reduce backwash flow and proper mineral bed cleaning.

## 6. FLUSH PIPES AND TEST FOR LEAKS

**CAUTION:** To avoid water or air pressure damage to filter inner parts, be sure to do the following steps exactly as listed:

- Fully open two filtered water faucets, one cold and one hot, nearby the filter.
- Place bypass valve(s) into "bypass" position. On a single valve, slide the stem inward to BYPASS (See Fig. 8 on page 6). On a 3 valve system, close the inlet and outlet valves, and open the bypass valve (See Fig. 7 on page 6).
- Fully open the house main water pipe shutoff valve. Observe a steady flow from both opened faucets.
- Close both faucets.
- Check your plumbing work for leaks and, if any are found, fix right away. Be sure to observe previous caution notes.
- Turn on the gas or electric supply to the water heater. Light the pilot, if applicable.

## 7. CONNECT TO ELECTRICAL POWER:

The filter controller works on 24V DC electrical power. The included power supply converts 120V AC household power to 24V DC. Plug the power supply into a 120V, 60 Hz electrical outlet. Be sure the outlet is always "live" so it can not be switched off by mistake.

## 8. PROGRAM THE CONTROLLER

See page 11 for instructions to program the electronic controller.

## 9. START UP PROCEDURE

- Confirm that the filter's main valve is in the "service" position ("S" on the cam).
- Place bypass valve(s) into "service", EXACTLY as follows:
  - Single Bypass Valve:** SLOWLY, pull the valve stem outward to "service" position, pausing several times to allow the filter to pressurize slowly.
  - 3 Valve Bypass:** Fully close the bypass valve and open the outlet valve. SLOWLY, open the inlet valve, pausing several times to allow the filter to pressurize slowly.
- Check all connections for leaks.
- Start a recharge:** From the rolling status screens, press the SELECT (O) button to display the **Main menu**. Make sure **Recharge** is highlighted, then press SELECT (O). Press DOWN (▼) to scroll to **Recharge now**, then press SELECT (O) twice. You should hear the valve motor run as the filter begins recharging. Verify that the valve advances to "backwash" (BW) position.
- Allow the unit to complete the backwash and fast rinse cycles (takes about 30 minutes). When the recharge ends, the filter valve automatically returns to "service". Start up is complete.

---

# General Information

## SEDIMENT FILTERS

A sediment filter removes, sand, clay, silt, or fine organic matter from water. You can see sediment in water by holding a sample, in a clear glass, up to a light. The particles are either suspended or settled to the bottom of the glass.

“Filter Aggregate” mineral mechanically filters the sediment particles as water passes through the bed. This mineral lasts indefinitely when properly maintained.

## ACID NEUTRALIZERS

Acidic water (6.0 to 6.8 pH) is corrected with an acid neutralizer filter. Acidic water, although sometimes clear in appearance, shortens the life of iron pipe, and corrodes copper or brass pipe and fittings. It causes green or blue stains on plumbing fixtures and may etch porcelain enamel over a period of time.

Acidic water, as it passes through the filter’s Neutralite mineral bed, dissolves some of the mineral. This raises the pH above 6.8, to neutralize the acid. Because the mineral does dissolve, the filter eventually needs refilling. The time between refills varies with the degree of acidity and how much water is used. The average life of the bed is about one year.

## TASTE & ODOR FILTERS

A taste and odor filter removes most tastes, odors and certain organic colors from water. Bad tastes and odors are due to a variety of causes (chlorine, petroleum, tannins, etc.). The activated carbon mineral of a taste and odor filter has a high capacity for absorbing these impurities.

The activated carbon bed usually lasts for about one year. However, high amounts of tastes and odors and/or excessive water usage may shorten this time. Activated carbon is nonregenerative and needs replacing when exhausted.

# Sanitizing Procedure

Care is taken at the factory to keep your water filter clean and sanitary. Materials used to make the filter will not infect or contaminate your water supply, and will not cause bacteria to form or grow. However, during shipping, storage, installing and operating, bacteria could get into the filter or media. For this reason, sanitizing as follows is suggested\* when installing.

Pour about 2 oz. of the following disinfectant into the filter:

1. Calcium hypochlorite, available in granular or tablet form, under trade names such as Perchloron or HTH.
2. Common 5.25% household bleach, such as Clorox.

**NOTE: ACTIVATED CARBON FILTERS** - Activated carbon will absorb the sanitizing agent, expending some capacity.

**Start a recharge:** From the rolling status screens, press the SELECT (O) button to display the **Main menu**. Make sure **Recharge** is highlighted, then press SELECT (O). Press DOWN (▼) to scroll to **Recharge now**, then press SELECT (O) twice. You should hear the valve motor run as the filter begins recharging. This recharge flushes “fines” from the new mineral. The sanitizing bleach and any air remaining in the unit are purged to the drain.

The filter returns to service in about 30 minutes. After the recharge has completed, fully open a cold water faucet downstream from the filter and allow 50 gallons of water to pass through the filter. This should take 20 minutes. Close the faucet. Sanitizing process is complete.

**\*NOTE:** Sanitizing is recommended by the Water Quality Association for disinfecting. On some water supplies, they suggest periodic sanitizing.

# Setup Procedure

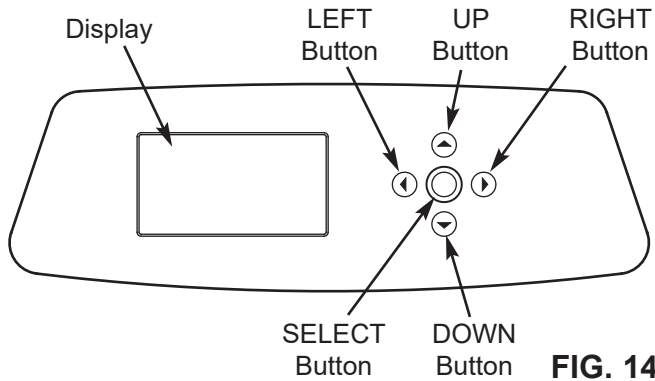

FIG. 14

## SETUP PROCEDURE

When the filter system is plugged in for the first time, a beep sounds and the display briefly shows model information. Next, a series of “wizard” screens prompts you to enter basic operating information:



FIG. 15

- 1. LANGUAGE** If the desired language already has a black dot next to it (See Figure 15), go to Step 2. Otherwise, press the filter’s DOWN (▼) or UP (▲) buttons to scroll to the desired language, then press the SELECT (○) button to choose it.
- Press the SELECT (○) button to advance to the next “wizard” screen.

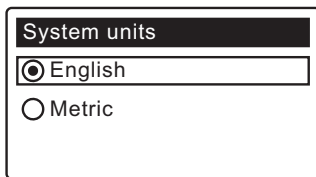

FIG. 16

- 3. SYSTEM UNITS** If the desired system already has a black dot next to it (See Figure 16), go to Step 4. Otherwise, press the DOWN (▼) or UP (▲) buttons to scroll to the desired system, then press the SELECT (○) button to choose it.
- Press the SELECT (○) button.



FIG. 17

- 5. CURRENT TIME** Press the DOWN (▼) or UP (▲) buttons to set the current time (See Figure 17). Hold the button down to rapidly advance. Be sure that AM or PM is correct. If the system units were set to metric in Step 3, the clock will be in 24-hour format.

- Press the SELECT (○) button.

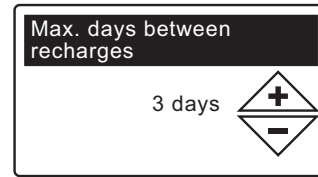

FIG. 18

- 7. MAX. DAYS BETWEEN RECHARGES** Press the UP (▲) or DOWN (▼) buttons to set the number of days between automatic recharges (See Figure 18) The feature can be set from 1 to 99 days.

No. of People	Iron (parts per million)			
	1 - 2	3 - 4	5 - 7	8 - 20
1 - 2	4 days	3 days	2 days	1 day
3	4 days	3 days	1 day	1 day
4 - 5	3 days	2 days	1 day	1 day
6 - 7	2 days	1 day	1 day	1 day

Use the table above to determine the number of days between recharges, based on the number of people in the household and the iron ppm (parts per million) in the water supply.

**NOTE:** If the water supply has high turbidity (sand, silt, sediments, etc.) set to recharge more often than the table shows.

- Press the SELECT (○) button. The screen will show “Setup complete!” (See Figure 19).

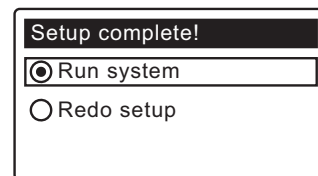

FIG. 19

- If, at this point, you want to go back and make changes, press the DOWN (▼) button to scroll to **Redo setup**, then press the SELECT (○) button twice to repeat the “wizard” screens.
- If no changes are desired, make sure **Run system** has a black dot next to it (See Figure 19) and press the SELECT (○) button. The unit begins normal operation, described on the next page.

# Programming the Water Filter

## NORMAL OPERATION

### FILTER STATUS SCREENS

During normal operation, the water filter's display shows up to three status screens. Page 16 explains how individual screens can be turned on or off. Each is shown for six seconds, in a rolling sequence (See Figure 20).

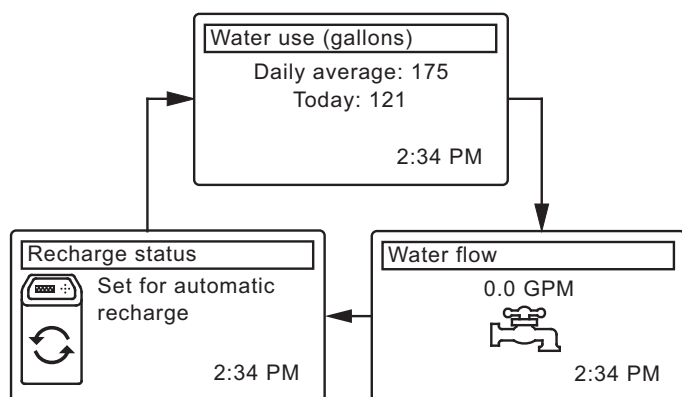

FIG. 20

Pressing the filter's RIGHT (▶) button manually advances to the next screen in the sequence. Pressing the LEFT (◀) button manually returns to the previous status screen. If no buttons are pressed for 30 seconds, the automatic rolling sequence resumes.

If **Recharge off** has been selected, as described on page 14, the rolling sequence will stop at the "Recharge status" screen.

## OTHER MESSAGES, ALERTS & REMINDERS

The filter status screens described in the previous section will not be displayed in a rolling sequence when one of the following items is displayed:

- **Recharge status** (Displayed during recharges, showing valve position and time remaining)
- **Recharge status: Off - no automatic recharges** instead of rolling screens indicates that automatic recharges have been turned off (See Page 14).
- **Current time** setting screen instead of status screens indicates time has been lost, perhaps after a long power loss. Set the time (See next page).
- **Service reminder** (See Page 19)
- **Error detected** (Contact your dealer for service)

## FLASHING DISPLAY

The filter's display will flash on and off when one or more of the following conditions occurs:

- Time needs to be set (Time has been lost)
- Service is overdue (Service reminder)
- Error condition

The flashing will stop after any key is pressed. However, it will start again at Midnight if the underlying condition (e.g. time not set) has not been addressed.

## LONG DISPLAY SCREEN MESSAGES

Most messages in the filter's display screens are short enough to be shown as a single line. Longer messages will be truncated (See Figure 21 for an example) until you highlight them.

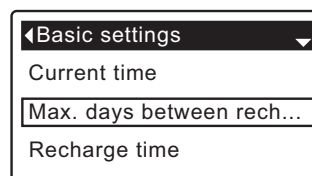

FIG. 21

One second after being highlighted, the viewing box expands (See Figure 22) to show the entire message. After three seconds the view resets (Figure 21).

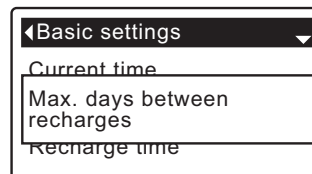

FIG. 22

# Programming the Water Filter

## MAIN MENU

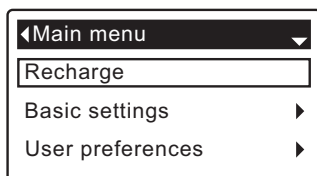

FIG. 23

During normal operation (status screens rolling), press the filter's SELECT (O) button to display the Main menu (See Figure 23). This menu and its subsidiary screens are used to control these operations:

- **Recharge** (See Page 14)
- **Basic settings**
  - **Current time** (See next column)
  - **Max. days between recharges** (See Page 15)
  - **Recharge time** (See Page 16)
  - **Rolling screens** (See Page 16)
- **User preferences**
  - **Language** (See Page 17)
  - **Time format** (See Page 17)
  - **Volume units** (See Page 17)
- **System information**
  - **Model information** (See Page 20)
  - **Daily avg. water used** (See Page 20)
  - **Water used today** (See Page 20)
  - **Total water used** (See Page 20)
  - **Current water flow** (See Page 20)
  - **Days powered up** (See Page 20)
  - **Last recharge** (See Page 20)
  - **Total recharges** (See Page 20)
- **Advanced settings**
  - **Cycle times**
    - **Fill time** (See Page 19)
    - **Draw time** (See Page 19)
    - **Backwash time** (See Page 18)
    - **Second backwash (On/Off)** (See Page 18)
    - **Second backwash time** (See Page 18)
    - **Fast rinse time** (See Page 18)
  - **Special features**
    - **Auxiliary control** (See Page 21)
    - **Chemical feed volume\*** (See Page 21)
    - **Chemical feed timer\*** (See Page 21)
    - **Service reminder** (See Page 19)
  - **Troubleshooting**
    - **Diagnostics** (See Page 22)
    - **Setup changes** (See Page 22)

\* Only displayed if Auxiliary control is set to Chemical feed.

## SETTING THE CURRENT TIME

When the filter's electronic control is first powered up, a "wizard" screen prompts you to set the current time (See Page 10). To change the time at a later date, such as after a long power loss:

1. From any of the rolling status screens, press the SELECT (O) button to display the **Main menu**.
2. Press the DOWN (▼) button to scroll through the menu options until **Basic settings** is highlighted (See Figure 24).

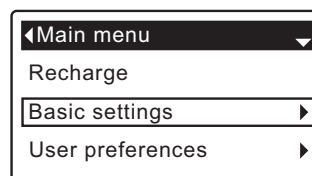

FIG. 24

3. Press the SELECT (O) button to display the Basic settings menu (See Figure 25).

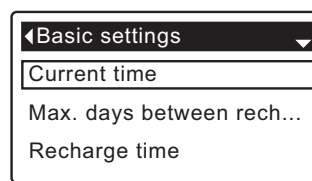

FIG. 25

4. Make sure **Current time** is highlighted.
5. Press the SELECT (O) button to display the Current time screen (See Figure 26).

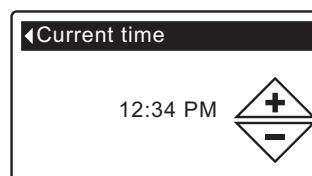

FIG. 26

6. Press the UP (▲) or DOWN (▼) buttons to change the time. Hold the button down to rapidly advance. Be sure that AM or PM is correct (unless filter is set for a 24-hour clock).
7. Press the SELECT (O) button. The display will go back to the Basic settings menu (Figure 25).
8. Press the LEFT (◀) button twice to return to the rolling status screens.

# Programming the Water Filter

## LOCKOUT FEATURE

A “lockout” feature is available to prevent user modification of parameters that affect filter performance. The unit is shipped from the factory with the lockout feature off. After programming is complete, the lockout feature can be turned on to prevent changes to the following:

- Max days between recharges
- Fill time
- Draw time
- Backwash time
- Second backwash (On/Off)
- Second backwash time
- Fast rinse time
- Auxiliary control
- Chemical feed volume
- Chemical feed timer
- Service reminder
- Setup changes

### To turn on the lockout feature:

1. From any of the rolling status screens, press the SELECT (O) button to display the **Main menu**.
2. Press the DOWN (▼) button to scroll through the menu options until **Advanced settings** is highlighted.
3. Press the SELECT (O) button to display the Advanced settings menu.
4. Press the DOWN (▼) button to scroll through the menu options until **Troubleshooting** is highlighted.
5. Press the SELECT (O) button to display the Troubleshooting menu.
6. Press the DOWN (▼) button to scroll through the menu options until **Setup changes** is highlighted.
7. Press the SELECT (O) button to display the Setup changes menu (See Figure 27).

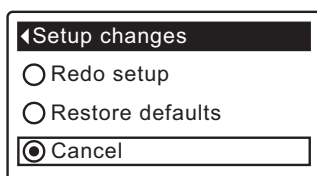

FIG. 27

8. Press the RIGHT (▶) button. A flashing padlock icon will appear, as shown in Figure 28.

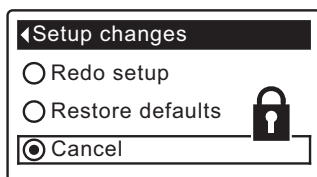

FIG. 28

9. Press the SELECT (O) button.
10. Press the LEFT (◀) button three times to return to the rolling status screens.

When the lockout feature is on, the flashing padlock icon will appear in any screen that would normally be used to change a parameter in the list to the left. For example, the **Max. days between recharges** screen will look like Figure 30, instead of Figure 29.

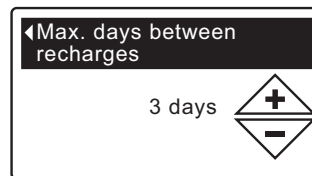

FIG. 29

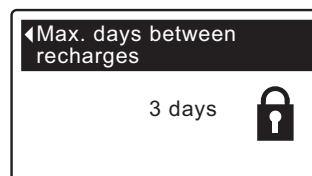

FIG. 30

Another indicator that the lockout feature is on is the **Model Information** screen. This screen appears on power-up, and can also be displayed from the System Information menu (See Page 20). If the lockout feature is on, there will be a non-flashing padlock icon in the upper right corner (See Figure 31).

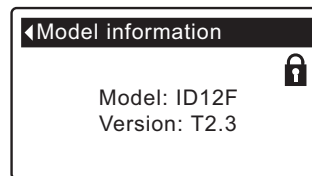

FIG. 31

### To turn off the lockout feature:

- 1-7. Go to the **Setup changes** screen (Figure 28) by following Steps 1-7 at left.
8. Press the RIGHT (▶) button. The flashing padlock icon will disappear, as shown in Figure 27.
9. Press the SELECT (O) button.
10. Press the LEFT (◀) button three times to return to the rolling status screens.

# Programming the Water Filter

## RECHARGING THE FILTER

This feature may be used to assure an adequate supply of conditioned water at times of unusually high water use. For example, if you have guests you could deplete conditioned water capacity before the next automatic recharge. Initiating a manual recharge will restore 100% conditioned water capacity after complete.

1. From any of the rolling status screens, press the SELECT (O) button to display the **Main menu**.

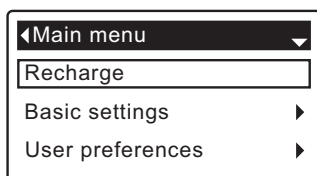

FIG. 32

2. Make sure **Recharge** is highlighted (See Figure 42).
3. Press the SELECT (O) button to display the Recharge menu (See Figure 33).

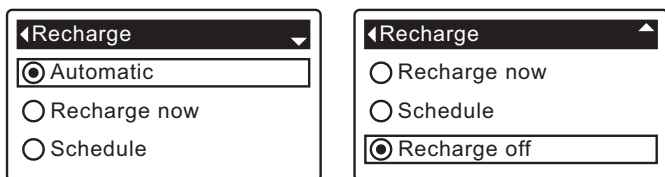

FIG. 33

4. If the desired option already has a black dot next to it (See Figure 33), go to Step 5. Otherwise, press the DOWN (▼) or UP (▲) buttons to scroll to the desired option, then press SELECT (O) to choose it.

- **Automatic** cancels a manually scheduled recharge (if it has not already begun) and lets the electronic control determine when to recharge next.

- **Recharge now** begins a recharge immediately after the SELECT (O) button is pushed again in Step 5.

- **Schedule** sets a recharge to begin at the preset recharge time (set according to the instructions on Page 16).

- **Recharge off** puts the system into a "vacation mode" where there will be no automatic recharges. This can be used during any long absence when you do not want the system using water. The recharge status screen will display "No automatic recharges". When you return, be sure to cancel **Recharge off** by setting recharge to **Automatic** or **Schedule**. Initiating **Recharge now** does not cancel **Recharge off**.

5. Press the SELECT (O) button. If **Recharge now** is selected, the display immediately goes to the Recharge status screen (See Figure 34).

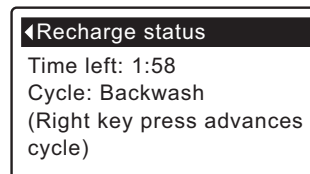

FIG. 34

6. Press the LEFT (◀) button (twice from the Recharge status screen) to return to the rolling status screens. If **Recharge off** was selected, the normal sequence of rolling screens will stop at the screen shown in Figure 35.

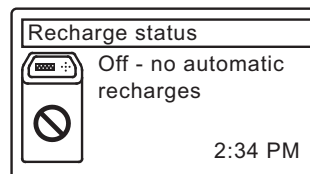

FIG. 35

# Programming the Water Filter

## SETTING MAXIMUM DAYS BETWEEN RECHARGES

When the filter's electronic control is first powered up, a "wizard" screen prompts you to set the number of days between automatic recharges (See Page 10). To change it:

1. From any of the rolling status screens, press the SELECT (O) button to display the **Main menu**.
2. Press the DOWN (▼) button to scroll through the menu options until **Basic settings** is highlighted (See Figure 36).

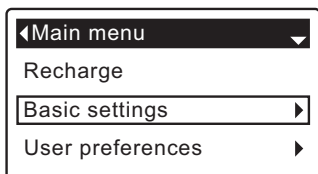

FIG. 36

3. Press the SELECT (O) button to display the Basic settings menu (See Figure 37).

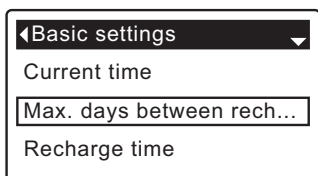

FIG. 37

4. Press the DOWN (▼) button to scroll through the menu options until **Max. days between rech...** is highlighted.
5. Press the SELECT (O) button to display the Max. days between recharges screen (See Figure 38).

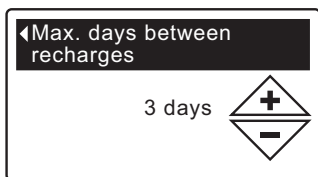

FIG. 38

6. Press the UP (▲) or DOWN (▼) buttons to change the number of days between automatic recharges. The feature can be set from 1 to 99 days.

No. of People	Iron (parts per million)			
	1 - 2	3 - 4	5 - 7	8 - 20
1 - 2	4 days	3 days	2 days	1 day
3	4 days	3 days	1 day	1 day
4 - 5	3 days	2 days	1 day	1 day
6 - 7	2 days	1 day	1 day	1 day

Use the table above to determine the number of days between recharges, based on the number of people in the household and the iron ppm (parts per million) in the water supply.

**NOTE:** If the water supply has high turbidity (sand, silt, sediments, etc.) set to recharge more often than the table shows.

7. Press the SELECT (O) button. The display will go back to the Basic settings menu (Figure 37).
8. Press the LEFT (◀) button twice to return to the rolling status screens

# Programming the Water Filter

## SETTING RECHARGE TIME

When the filter's electronic control is first powered up, the default time for starting an automatic recharge is 12:00 a.m. This is a good time in most households because water is not being used. To change this time:

1. From any of the rolling status screens, press the SELECT (O) button to display the **Main menu**.
2. Press the DOWN (▼) button to scroll through the menu options until **Basic settings** is highlighted (See Figure 39).

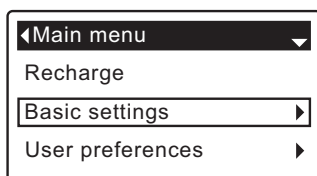

FIG. 39

3. Press the SELECT (O) button to display the Basic settings menu (See Figure 40).

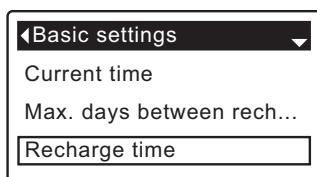

FIG. 40

4. Press the DOWN (▼) button to scroll through the menu options until **Recharge time** is highlighted.
5. Press the SELECT (O) button to display the Recharge time screen (See Figure 41).

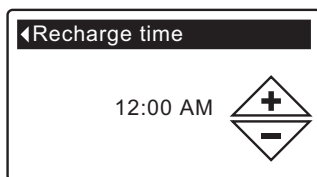

FIG. 41

6. Press the UP (▲) or DOWN (▼) buttons to change the recharge time in 1 hour increments. Hold the button down to rapidly advance. Be sure that AM or PM is correct (unless filter is set for a 24-hour clock).
7. Press the SELECT (O) button. The display will go back to the Basic settings menu (Figure 40).
8. Press the LEFT (◀) button twice to return to the rolling status screens.

## MODIFYING ROLLING SCREENS

During normal filter operation, up to four status screens are shown in sequence (See "Filter Status Screens" on Page 11). When the filter's electronic control is first powered up, the default is to show all four. You can turn on/off individual screens\*:

1. From any of the rolling status screens, press the SELECT (O) button to display the **Main menu**.
2. Press the DOWN (▼) button to scroll through the menu options until **Basic settings** is highlighted (See Figure 42).

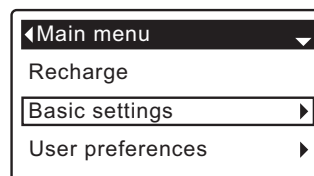

FIG. 42

3. Press the SELECT (O) button to display the Basic settings menu (See Figure 43).

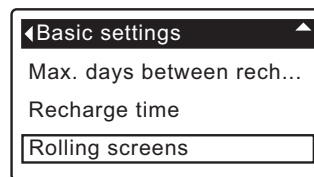

FIG. 43

4. Press the DOWN (▼) button to scroll through the menu options until **Rolling screens** is highlighted.
5. Press the SELECT (O) button to display the Rolling screens menu (See Figure 44).

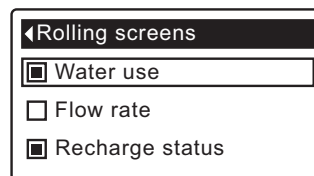

FIG. 44

6. Press the DOWN (▼) or UP (▲) buttons to scroll through the list. Items with a black square next to them will be displayed during normal operation.
7. To un-select a screen, make sure its name is highlighted in a box. Then press the SELECT (O) button. The black square will disappear. Pressing SELECT (O) again makes the black square reappear and re-selects the highlighted item. At least one screen must be selected/highlighted.
8. When selections are complete, exit this menu by pressing the LEFT (◀) button. The display will go back to the Basic settings menu (Figure 43).
9. Press the LEFT (◀) button twice to return to the rolling status screens.

\*This does not include service reminders, errors, alerts or Recharge status screens.

# Programming the Water Filter

## SETTING THE LANGUAGE

When the filter's electronic control is first powered up, a "wizard" screen prompts you to set the language (See Page 10). To change the language:

1. From any of the rolling status screens, press the SELECT (O) button to display the **Main menu**.
2. Press the DOWN (▼) button to scroll through the menu options until **User preferences** is highlighted (See Figure 45).

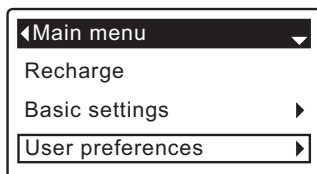

FIG. 45

3. Press the SELECT (O) button to display the User preferences menu (See Figure 46).

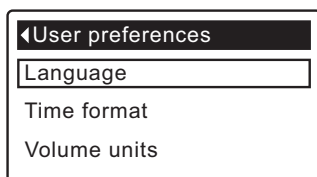

FIG. 46

4. Make sure **Language** is highlighted.
5. Press the SELECT (O) button to display the Language menu (See Figure 47).

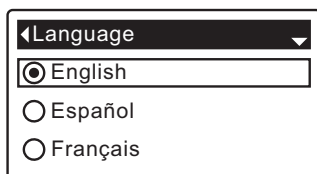

FIG. 47

6. If the desired language already has a black dot next to it (See Figure 57), go to Step 7. Otherwise, press the DOWN (▼) or UP (▲) buttons to scroll to the desired language, then press SELECT (O) to choose it. The choices are: English, Spanish, French, Italian, German, Dutch, Polish, Russian, Hungarian, Turkish, Lithuanian, Greek, Romanian, Czech, Slovak, Bulgarian, Serbian or Croatian.
7. Press the SELECT (O) button. The display will go back to the User preferences menu (Figure 46).
8. Press the LEFT (◀) button twice to return to the rolling status screens.

### TO SET THE FILTER TO ENGLISH IF ANOTHER LANGUAGE IS DISPLAYED:

From the rolling status screens, press SELECT (O). Press DOWN (▼) twice, then press SELECT (O) twice. Press UP (▲) to scroll to **English** at the top of the list, then press SELECT (O) twice. Press LEFT (◀) twice to exit all menus.

## SETTING TIME FORMAT

Use this feature to select a 12-hour (AM/PM) or 24-hour clock.

1. From any of the rolling status screens, press the SELECT (O) button to display the **Main menu**.
2. Press the DOWN (▼) button to scroll through the menu options until **User preferences** is highlighted.
3. Press the SELECT (O) button to display the User preferences menu.
4. Press the DOWN (▼) button to scroll through the menu options until **Time format** is highlighted.
5. Press the SELECT (O) button to display the Time format menu (See Figure 48).

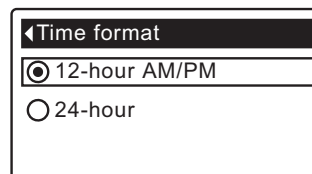

FIG. 48

6. If the desired time format already has a black dot next to it (See Figure 48), go to Step 7. Otherwise, press the DOWN (▼) or UP (▲) buttons to scroll to the other time format, then press SELECT (O) to choose it.
7. Press the SELECT (O) button. The display will go back to the User preferences menu.
8. Press the LEFT (◀) button twice to return to the rolling status screens.

## SETTING VOLUME UNITS

Use this feature to select gallons or liters as volume units.

- 1-3. Go to the **User preferences** menu by following Steps 1-3 in "Setting Time Format" above.
4. Press the DOWN (▼) button to scroll through the menu options until **Volume units** is highlighted.
5. Press the SELECT (O) button to display the Volume units menu (See Figure 49).

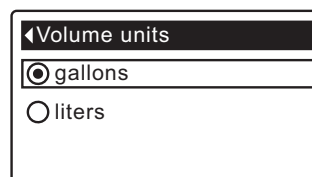

FIG. 49

6. If the desired volume unit already has a black dot next to it (See Figure 49), go to Step 7. Otherwise, press the DOWN (▼) or UP (▲) buttons to scroll to the other volume unit, then press SELECT (O) to choose it.
7. Press the SELECT (O) button. The display will go back to the User preferences menu.
8. Press the LEFT (◀) button twice to return to the rolling status screens.

# Programming the Water Filter

## CYCLE TIMES

Use these features to change the following filter operations:

- **Fill time** (described on the next page)
- **Draw time** (described on the next page)
- **Backwash time**
- **Second backwash (On/Off)**
- **Second backwash time**
- **Fast rinse time**

To display these screens:

1. From any of the rolling status screens, press the SELECT (O) button to display the **Main menu**.
2. Press the DOWN (▼) button to scroll through the menu options until **Advanced settings** is highlighted (See Figure 50).

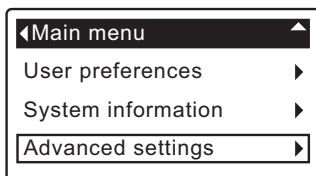

FIG. 50

3. Press the SELECT (O) button to display the Advanced settings menu (See Figure 51).

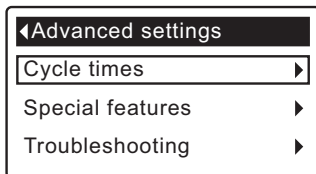

FIG. 51

4. Make sure **Cycle times** is highlighted.
5. Press the SELECT (O) button to display the Cycle times menu (See Figure 52).

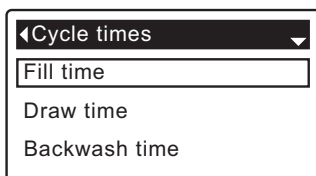

FIG. 52

6. Press the DOWN (▼) button to scroll through the menu options until the desired option is highlighted (See list at the top of this column).
7. Press the SELECT (O) button to display the desired cycle time screen (See Figures 53-58).
8. **See the next two columns for specific instructions on each cycle time screen.**
9. Press the SELECT (O) button. The display will go back to the Cycle times menu (Figure 52).
10. Press the LEFT (◀) button three times to return to the rolling status screens.

- 8c. **Backwash time:** Press the UP (▲) or DOWN (▼) buttons to change the backwash time. Hold the button down to rapidly advance. The backwash time can be set from 1 to 99 minutes\* (See Figure 53).



FIG. 53

- 8d. **Second backwash (On/Off):** If the desired option already has a black dot next to it (See Figure 54), go to Step 9. Otherwise, press the DOWN (▼) or UP (▲) buttons to scroll to the other option, then press SELECT (O) to choose it. Setting this feature On adds a second backwash and rinse at the beginning of the recharge cycle. Default is Off. Set this feature On if your water supply contains a lot of sediment or iron.

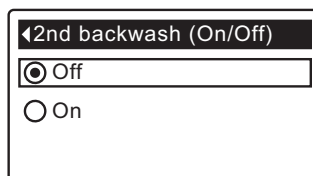

FIG. 54

- 8e. **Second backwash time:** Press the UP (▲) or DOWN (▼) buttons to change the second backwash time. Hold the button down to rapidly advance. The time can be set from 0 to 15 minutes (See Figure 55).



FIG. 55

- 8f. **Fast rinse time:** Press the UP (▲) or DOWN (▼) buttons to change the fast rinse time. Hold the button down to rapidly advance. The fast rinse time can be set from 1 to 99 minutes\* (See Figure 56).

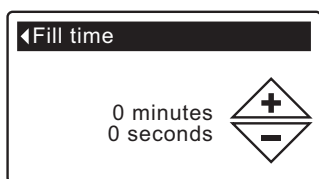

FIG. 56

\*Reducing the backwash and fast rinse times below a filter model's default settings is not recommended.

# Programming the Water Filter

- 8a. Fill time:** Press the UP (▲) or DOWN (▼) buttons to change the fill time. Hold the button down to rapidly advance. The fill time can be set from 0:00 to 99:59 minutes (See Figure 57).



**FIG. 57**

- 8b. Draw time:** Press the UP (▲) or DOWN (▼) buttons to change the draw time. Hold the button down to rapidly advance. The draw time can be set from 0 to 255 minutes (See Figure 58).

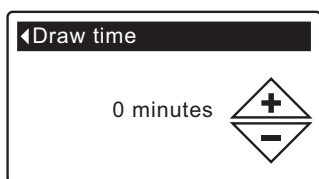

**FIG. 58**

## SPECIAL FEATURES

Use these features to change the following operations:

- **Auxiliary control** (described on Page 21)
- **Chemical feed volume\*\*** (described on Page 21)
- **Chemical feed timer\*\*** (described on Page 21)
- **Service reminder** (described below)

## SERVICE REMINDER (set / reset)

Use this feature to program the number of months (up to 24) before a "Service overdue" message will appear instead of the rolling status screens (See Figure 59).

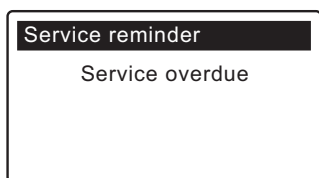

**FIG. 59**

This will be a reminder to call your dealer for service. Once programmed, this feature displays the number of months and days left until the service reminder.

Once the "Service overdue" message has appeared, dealers performing service clear it by setting the num-

ber of months until the next service reminder. Set or reset the service reminder as follows:

1. From any of the rolling status screens, press the SELECT (O) button to display the **Main menu**.
2. Press the DOWN (▼) button to scroll through the menu options until **Advanced settings** is highlighted.

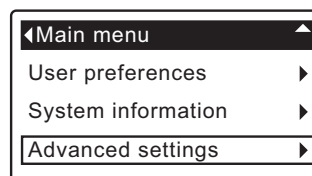

**FIG. 60**

3. Press the SELECT (O) button to display the Advanced settings menu (See Figure 61).

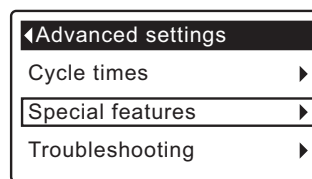

**FIG. 61**

4. Press the DOWN (▼) button to scroll through the menu options until **Special features** is highlighted.
5. Press the SELECT (O) button to display the Special features menu (See Figure 62).

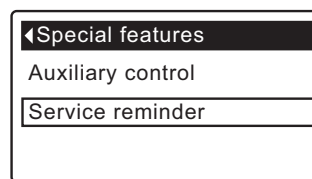

**FIG. 62**

6. Press the DOWN (▼) button to scroll through the menu options until **Service reminder** is highlighted.
7. Press the SELECT (O) button to display the Service reminder screen (See Figure 63).

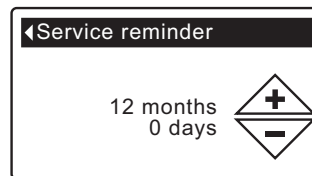

**FIG. 63**

8. Press the UP (▲) or DOWN (▼) buttons to set the number of months until the service reminder appears. Repeatedly pressing the DOWN (▼) button until the display reads "Off" turns this feature off and zeros the number of months and days.
9. Press the SELECT (O) button. The display will go back to the Special features menu (Figure 62).
10. Press the LEFT (◀) button three times to return to the rolling status screens.

\*\*Only displayed if Auxiliary control is set to Chemical feed.

# Programming the Water Filter

## SYSTEM INFORMATION

Use these features to look up the following information about the filter and its operations:

- **Model information** (model number and software version)
- **Daily average water used**
- **Water used today**
- **Total water used** (explained in Step 6, below)
- **Current water flow**
- **Days powered up**
- **Last recharge**
- **Total recharges**

To display one of these screens:

1. From any of the rolling status screens, press the SELECT (O) button to display the **Main menu**.
2. Press the DOWN (▼) button to scroll through the menu options until **System information** is highlighted (See Figure 64).

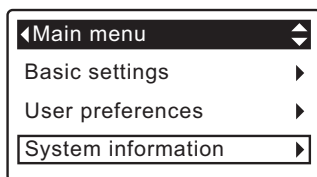

FIG. 64

3. Press the SELECT (O) button to display the System information menu (See Figure 65).

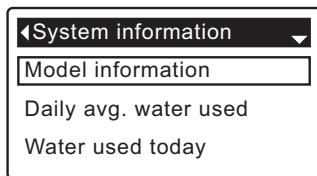

FIG. 65

4. Press the DOWN (▼) button to scroll through the menu options until the desired option is highlighted (See list at the top of this column).
5. Press the SELECT (O) button to display the desired information screen (See Figures 65-73).
6. The **Total water used** screen (See Figure 69) shows the volume of water used since it was last reset (it works like the trip odometer in a car). To reset the value to 0, press the RIGHT (▶) button while this screen is displayed.
7. When finished viewing an information screen, press the SELECT (O) button. The display will go back to the System information menu (Figure 65). It will also exit automatically if no buttons are pressed for four minutes.
8. Press the LEFT (◀) button twice to return to the rolling status screens.

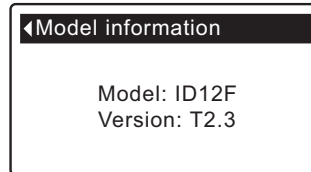

FIG. 66

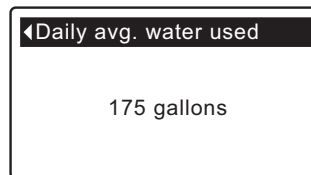

FIG. 67

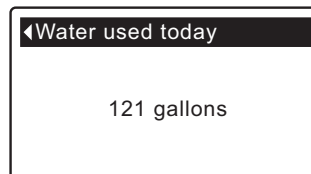

FIG. 68

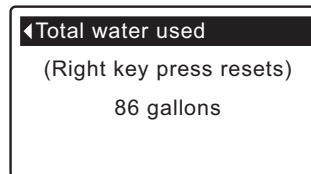

FIG. 69

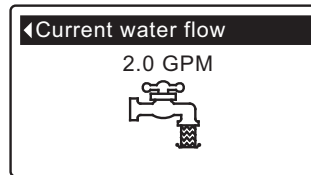

FIG. 70

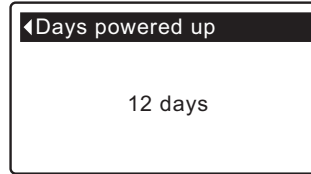

FIG. 71

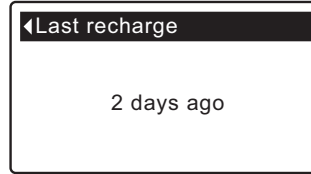

FIG. 72

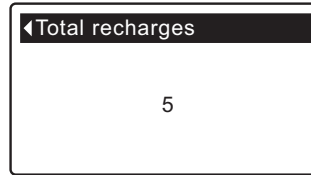

FIG. 73

# Programming the Water Filter

## AUXILIARY CONTROL

The electronic control has an auxiliary output which can control external devices in a water treatment system. The signal is 24V DC, current draw 500 mA maximum. The Auxiliary Output terminals are located on the electronic control board (See Schematic on Page 25).

To select an auxiliary control mode:

1. From any of the rolling status screens, press the SELECT (O) button to display the **Main menu**.
2. Press the DOWN (▼) button to scroll through the menu options until **Advanced settings** is highlighted.
3. Press the SELECT (O) button to display the Advanced settings menu.
4. Press the DOWN (▼) button to scroll through the menu options until **Special features** is highlighted.
5. Press the SELECT (O) button to display the Special features menu (See Figure 74).

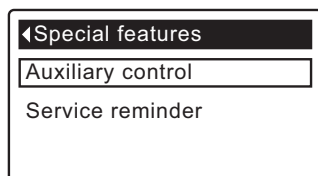

FIG. 74

6. Make sure **Auxiliary control** is highlighted.
7. Press the SELECT (O) button to display the Auxiliary control menu (See Figure 75).
8. If the desired option already has a black dot next to it (See Figure 75), go to Step 9. Otherwise, press the DOWN (▼) or UP (▲) buttons to scroll to the desired option, then press SELECT (O) to choose it.
  - **Off** is the default. The 24V DC output is always off.
  - **On**: The 24V DC output is always on.
  - **Chlorine** can be used to drive a chlorine generator, which produces chlorine, as water passes through it, to sanitize the media during recharges.
  - **Bypass**: Turns 24V DC on during the entire regeneration cycle (when the filter's valve is in bypass and unfiltered is going to the house).
  - **Chemical feed**: Can be used to run a chemical feed pump. If chosen, the chemical feed volume and timer must be set, as detailed at right.
  - **Water use**: Turns 24V DC on when the filter's turbine indicates water flow. Could drive an air pump for iron or sulfur oxidation.
  - **Fast Rinse**: Turns 24V DC on during the fast rinse portion of the regeneration cycle.
9. Press the SELECT (O) button. The display will go back to the Special features menu (Figure 74).
10. Press the LEFT (◀) button three times to return to the rolling status screens.

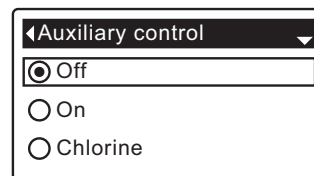

FIG. 75

## CHEMICAL FEED

If the auxiliary control mode has been set to **Chemical feed**, as described in the previous section, two additional lines (**Chemical feed volume** and **Chemical feed timer**) will appear on the Special features menu.

To set these values:

1. From any of the rolling status screens, press the SELECT (O) button to display the **Main menu**.
2. Press the DOWN (▼) button to scroll through the menu options until **Advanced settings** is highlighted.
3. Press the SELECT (O) button to display the Advanced settings menu.
4. Press the DOWN (▼) button to scroll through the menu options until **Special features** is highlighted.
5. Press the SELECT (O) button to display the Special features menu (See Figure 74).
6. Press the DOWN (▼) button to scroll through the menu options until **Chemical feed volume** or **Chemical feed timer** is highlighted.
7. Press the SELECT (O) button to display the Chemical feed volume or Chemical feed timer menu (See Figures 76 & 77).

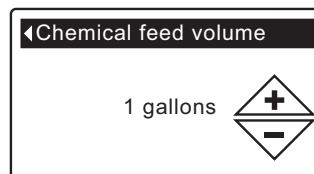

FIG. 76

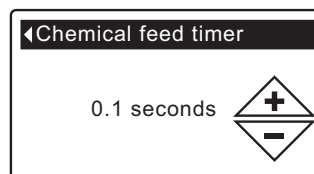

FIG. 77

8. Press the UP (▲) or DOWN (▼) buttons to change the value. Hold the button down to rapidly advance.
  - **Chemical feed volume** is the amount of water which will pass through the filter between each activation of the chemical feed equipment.
  - **Chemical feed timer** is how long the output to the chemical feed equipment is energized each time it is activated.
9. Press the SELECT (O) button. The display will go back to the Special features menu (Figure 74).
10. Press the LEFT (◀) button three times to return to the rolling status screens.

# Programming the Water Filter

## DIAGNOSTICS

This feature allows a service technician to check the operating state of individual components in the filter (e.g. valve position) to troubleshoot problems. **If an error code is displayed in place of the rolling status screens, call your dealer for service.**

To view the Diagnostics screen:

1. If an error code is displayed, skip Steps 2-7 and go directly to Step 8.
2. To display the Diagnostics screen from any of the rolling status screens (when an error code is not displayed), press the SELECT (O) button to display the **Main menu**.
3. Press the DOWN (▼) button to scroll through the menu options until **Advanced settings** is highlighted.
4. Press the SELECT (O) button to display the Advanced settings menu.
5. Press the DOWN (▼) button to scroll through the menu options until **Troubleshooting** is highlighted.
6. Press the SELECT (O) button to display the Troubleshooting menu (See Figure 78).

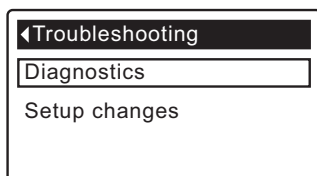

FIG. 78

7. Make sure **Diagnostics** is highlighted.
8. Press the SELECT (O) button to display the Diagnostics screen (See Figure 79).

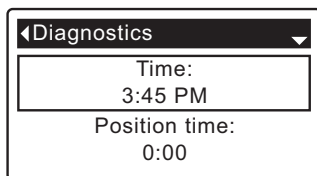

FIG. 79

9. Press the DOWN (▼) or UP (▲) buttons to scroll through the list. The following items are displayed:
  - **Time** (current)
  - **Position time** (counts down the time remaining in the current valve position)
  - **Current position** (of the valve: service, fill, brine, backwash, fast rinse or moving)
  - **Requested position** (of the valve)
  - **Motor state** (on or off)
  - **Valve position switch** (open or closed)
  - **Turbine count** (if changing, indicates water flow).
  - **Tank light switch** (open or closed)
  - **Error code** (call for service if a number is displayed)

continued

10. When finished viewing the Diagnostics screen, press the SELECT (O) button. The display will go back to the Troubleshooting menu.
11. Press the LEFT (◀) button three times to return to the rolling status screens (or error code screen if an error condition exists).

## SETUP CHANGES

This feature allows a service technician to repeat the setup procedure (See Page 10) or restore the filter's default operating values.

1. From any of the rolling status screens, press the SELECT (O) button to display the **Main menu**.
2. Press the DOWN (▼) button to scroll through the menu options until **Advanced settings** is highlighted.
3. Press the SELECT (O) button to display the Advanced settings menu.
4. Press the DOWN (▼) button to scroll through the menu options until **Troubleshooting** is highlighted.
5. Press the SELECT (O) button to display the Troubleshooting menu (See Figure 78).
6. Press the DOWN (▼) button to scroll through the menu options until **Setup changes** is highlighted.
7. Press the SELECT (O) button to display the Setup changes menu (See Figure 80).

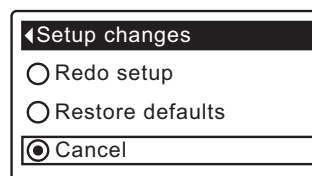

FIG. 80

8. If the desired option already has a black dot next to it (See Figure 80), go to Step 9. Otherwise, press the DOWN (▼) or UP (▲) buttons to scroll to the desired option, then press SELECT (O) to choose it.
  - **Redo setup** allows you to select a different model code (intended to be used for upgrades or retrofits of existing filters). Model codes are listed on Page 3.
  - **Restore defaults** will reset all customizable settings to their default values and take you through the "wizard" screen setup procedure (See Page 10).
  - **Cancel** will return to the Troubleshooting menu (Figure 78).
9. Press the SELECT (O) button.

# Service Information

## NEUTRALIZING FILTER - CHECKING THE MINERAL LEVEL IN THE TANK

As explained on Page 9, the mineral dissolves in the water to neutralize the acid. How fast it dissolves depends on how much water your household uses and the pH of the water.

Every few months you should measure the mineral bed level in the tank. Always add new mineral before the tank is empty. To measure, do the following:

1. Referring to Page 14, initiate a "Recharge Now".
2. When water starts to run from the drain hose, put the plumbing bypass valve(s) into bypass position (See Figures 7 & 8 on page 6), TO DEPRESSURIZE THE FILTER.
3. Unplug the power supply at the wall outlet.
4. Remove the controller cover.
5. Disconnect the bypass valve or copper tubes from the inlet and outlet (See Page 7).
6. Remove retainer clips and clamp sections from the tank neck and carefully lift the valve off the tank.
7. Remove the top distributor and o-ring seals (See Page 5).
8. Use a yard stick or steel tape measure to find the distance down to the top of the mineral bed (See Figure 81). If it is lower than the suggested freeboard, shown in the table below, add more neutralite material.

Model	Suggested Freeboard
IDP12F	16"

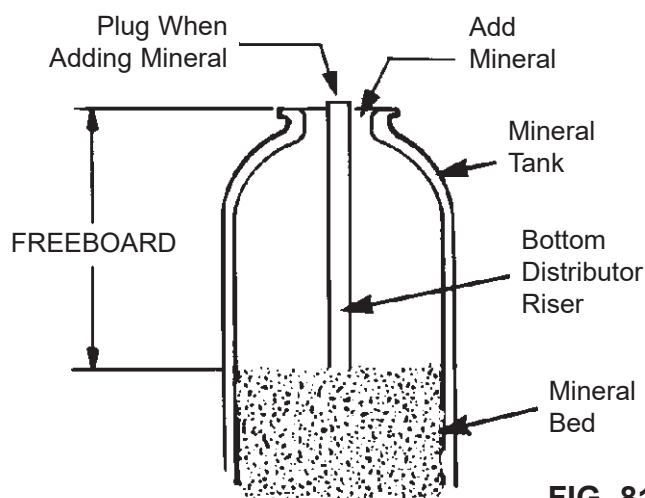

FIG. 81

9. When adding more mineral, use a funnel to add.
  10. Flush all mineral from the tank top opening. Then replace the distributor and four o-ring seals (See Figure 5 on Page 5).
  11. Do the following steps to return the filter to service:
    - Steps 10 and 11 on Page 5
    - Step 2 on Page 7
    - Step 5 on Page 8, if hose was disconnected
    - Steps 6, 7 and 9 on Page 8
- NOTE:** After electrical power is applied, if the time display is flashing, reset the clock (See Page 12).
- Initiate a "Recharge Now" (See Page 14).

## TASTE & ODOR FILTER - REPLACING THE ACTIVATED CARBON MINERAL BED

When the filter no longer removes tastes and/or odors from the water (See Page 9), the activated carbon bed must be replaced. To replace the bed:

1. Do Steps 1 through 7, at left.
2. Carefully lay the filter tank over. Pull the standpipe and bottom distributor from the mineral bed.
3. Dump the contents of the tank into a suitable container.
4. Stand the tank upright and put the bottom distributor and standpipe back in place.
5. Add the recommended amounts of gravel, filter sand, and activated carbon mineral. See "Specifications" on Page 3.
6. Do Steps 10 & 11, above.

# Service Information

## RELIEVING WATER PRESSURE WITH THE BYPASS VALVE(S)

**CAUTION:** Always relieve water pressure in the filter, as described below, before removing parts from the valve or media tank.

### DE-PRESSURIZE

1. Put bypass valve(s) into **Bypass** position.
2. Place filter valve in **Fill** position by performing Steps 1 & 5 of Manual Advance Recharge procedure on Page 27.

### PRESSURIZE

1. Put bypass valve(s) into **Service** position.
2. Return filter valve to **Service** position by performing Steps 6-11 of Manual Advance Recharge procedure on Page 27.

## ALTERNATE METHODS:

### 3-VALVE BYPASS (See Figure 82)

#### DE-PRESSURIZE

1. Close the INLET valve.
2. Open HOT and COLD conditioned water house faucets.
3. Close the OUTLET valve and open the BYPASS valve.
4. Close all house faucets.

#### PRESSURIZE

1. Open HOT and COLD house faucets.
2. Close the BYPASS valve and open the OUTLET valve.
3. **Slowly**, open the INLET valve.
4. Close all house faucets.

### SINGLE BYPASS VALVE

(See Figure 83)

#### DE-PRESSURIZE

1. Close the house main water supply valve.
2. Open HOT and COLD conditioned water house faucets.
3. Push the bypass valve handle to **Bypass** position.
4. Optional: For unfiltered water bypass to house faucets, reopen the main water supply valve.

#### PRESSURIZE

1. Open main water supply valve if it is closed.
2. Open HOT and COLD house faucets.
3. Pull the bypass valve handle to **Service** position.
4. Close all house faucets.

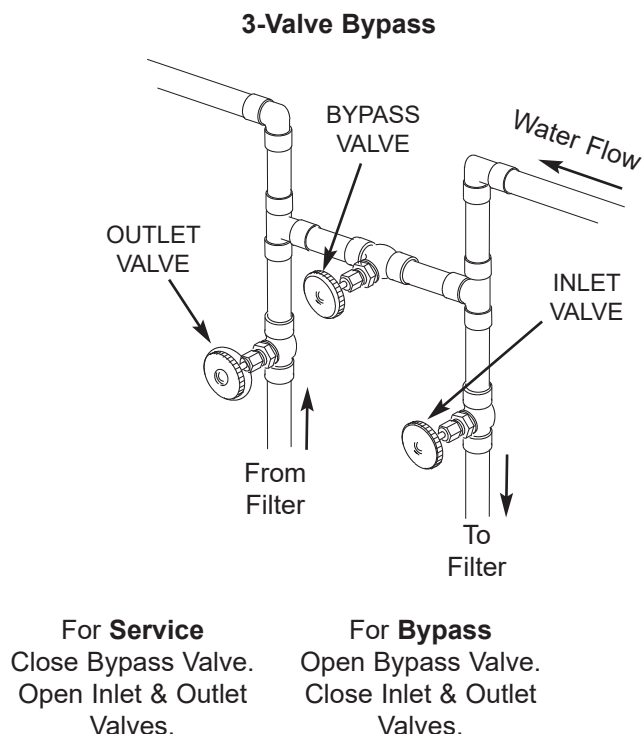

FIG. 82

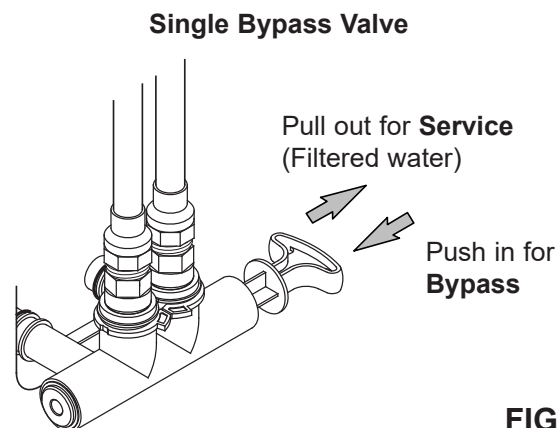



FIG. 83

# Troubleshooting

TROUBLESHOOTING GUIDE		
PROBLEM	CAUSE	CORRECTION
<b>Cannot set some filter parameters and display shows a padlock icon:</b> 	Lockout feature is on.	Turn off lockout feature (See Page 13).
<b>Status screen shows "No automatic recharges"</b>	Recharge is set to "Off" (vacation mode).	If you want automatic recharges, set recharge to either "Schedule" or "Automatic" (See Page 14).
<b>Air in house lines</b>	Riser tube o-ring.	Reseat or replace riser o-ring.
<b>Water to drain</b>	Defective rotor disc and seals.	Replace rotor disc and seals.
<b>Motor stalled or clicking</b>	Motor malfunction or internal valve fault causing high torque on motor.	Contact your dealer for service.
<b>Error code E1, E3 or E4 displayed.</b>	Fault in wiring harness, connections to position switch, switch, valve or motor.	Contact your dealer for service.
<b>Error code E5 displayed.</b>	Electronic control malfunction.	Contact your dealer for service.

## TROUBLESHOOTING - INITIAL CHECKS

**Always make these initial checks first:**

1. Is display blank? Check power source.
2. Is Error code displayed? If so, go to "Automatic Electronic Diagnostics" on the next page.
3. Is correct time displayed? If not, recharges occur at the wrong time. Set current time (See Page 12.)
4. Are plumbing bypass valve(s) in service position (See Figures 82 & 83 on Page 24)?

5. Are inlet and outlet pipes connected to the water filter inlet and outlet respectively?

6. Is valve drain hose free of kinks and sharp bends, and not elevated over 8 feet above the floor.

If no problem is found after making the initial checks, proceed to "Troubleshooting - Manual Diagnostics" and "Manual Advance Recharge Check" on the next two pages.

## WIRING SCHEMATIC

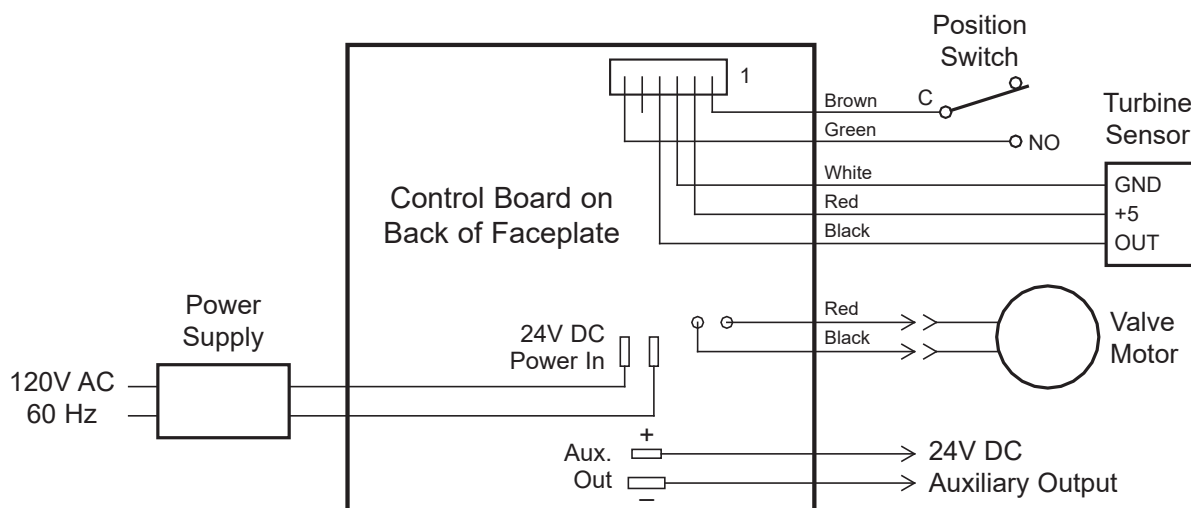

FIG. 84

# Troubleshooting

## AUTOMATIC ELECTRONIC DIAGNOSTICS

This filter has a self-diagnostic function for the electrical system (except for input power and/or water meter). The controller monitors electronic components and circuits for correct operation. If a malfunction occurs, an **Error code** is displayed (See Figure 85).

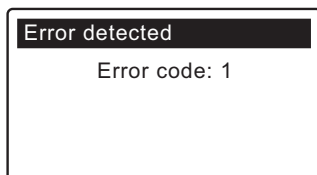

FIG. 85

The troubleshooting chart on the previous page shows the error codes that could appear, and the possible malfunctions for these codes.

When an error code appears in the display, pressing SELECT (O) will display the **Diagnostics** screen (See Page 22), so a service technician can further isolate the problem.

## REMOVING ERROR CODE

1. Unplug power supply from electrical outlet.
2. Correct problem.
3. Plug power supply back in.
4. Wait for 8 minutes while controller operates valve through an entire cycle. The error code will return if the problem was not corrected.

## TROUBLESHOOTING - MANUAL DIAGNOSTICS

1. Display the **Diagnostics** screen, following the procedure on Page 22.
2. Press the DOWN (▼) or UP (▲) buttons to scroll through the list. The following items are displayed:
  - **Time** (current)
  - **Position time** (counts down the time remaining in the current valve position)
  - **Current position** (of the valve: service, fill, brine, backwash, fast rinse or moving) See "Manual Advance Recharge Check" on the next page for position verification.
  - **Requested position** (of the valve)
  - **Motor state** (on or off)
  - **Valve position switch** (open or closed)
  - **Turbine count** (if changing, indicates water flow).
  - **Tank light switch** (open or closed)
  - **Error code**

## CHECKING THE TURBINE

1. Display the **Diagnostics** screen, following the procedure on Page 22.
2. Press the DOWN (▼) button to scroll through the list until **Turbine Count** is displayed (See Figure 86).

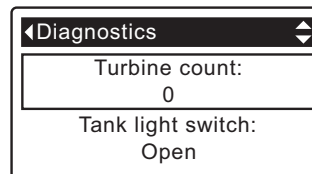

FIG. 86

3. A steady display of "0" (zero) indicates no water flow through the meter (i.e. no conditioned water being used).
4. Open a nearby conditioned water faucet.
5. The number in the display should count upward from 0 and reset at 140 for each gallon of flow.
6. If the display reading does not change with the faucet open, pull the wire harness from the valve outlet port (See Figure 87).

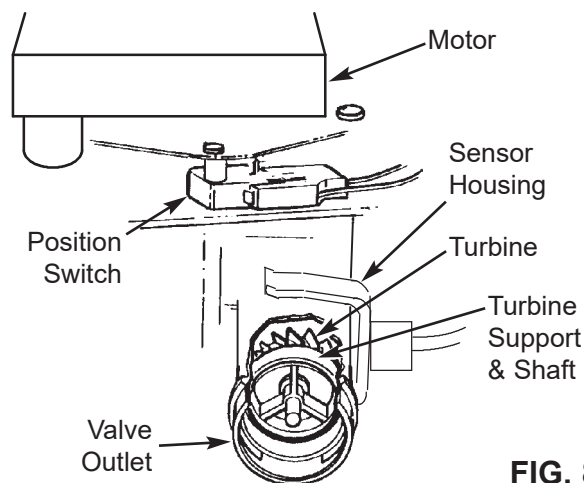

FIG. 87

7. Pass a small magnet back and forth in front of the sensor.
  - 8a. If the displayed **Turbine Count** does count upward with each pass of the magnet, disconnect the outlet plumbing and check the turbine for binding.
  - 8b. If the displayed **Turbine Count** does not count upward with each pass of the magnet, the sensor is probably faulty.

# Troubleshooting

## TROUBLESHOOTING - MANUAL ADVANCE RECHARGE CHECK

Use the following procedures to advance the filter through the recharge cycles to check operation. Always make the Initial Checks (See Page 25) and the Manual Diagnostics (See Page 26) first.

Remove the top cover by unlocking the tabs and lifting, to observe cam and switch operation during valve rotation (See Figure 90).

1. Display the **Diagnostics** screen, following the procedure on Page 22.
2. Press the DOWN (▼) button to scroll through the list until **Valve position switch** is displayed (See Figure 88).

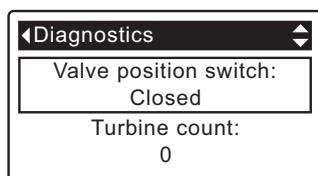

FIG. 88

3. Verify that when the switch plunger is down (into one of the detents on the valve motor cam), this screen reads **Open**. When the valve cam is rotating (for example, after Step 5, below), the switch plunger will be up and this screen should read **Closed**.
4. Press the UP (▲) button to scroll through the list until **Current position** is displayed (See Figure 89).

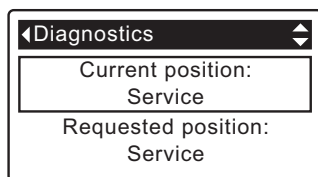

FIG. 89

5. With the Diagnostics screen displayed, press the RIGHT (▶) button once to advance the valve from **Service** to the next position.
6. Default fill time is zero, so the valve will not remain at the fill position unless fill time has been otherwise set. If stopped at **Fill**, press the RIGHT (▶) button again to advance to the next position.
7. Default draw time is zero, so the valve will not remain at the brine position unless draw time has been otherwise set. If stopped at **Brine\***, press the RIGHT (▶) button again to advance to the next position.
8. Verify that the valve position indicator on the motor cam agrees with the position displayed on the screen
9. Once in **Backwash**, look for a fast flow of water from the drain hose. If flow is slow, check for a plugged top distributor, backwash flow plug or drain hose

\* If the 2nd Backwash option is set (See Page 18), the valve will enter backwash and fast rinse before brine.

10. With the Diagnostics screen displayed, once again press the RIGHT (▶) button to advance the valve to **Fast Rinse**. Again, look for a drain flow rate about the same as backwash.
11. With the Diagnostics screen displayed, once again press the RIGHT (▶) button to return the valve to the **Service** position.

**IMPORTANT:** Always return the valve to the **Service** position before exiting this procedure.

## OTHER SERVICE

**Unfiltered Water Bypass** (Unfiltered water “bleeds” into filtered water supply):

1. Faulty rotor disc, seal or wave washer (See Pages 30 and 31).
2. Missing or faulty o-ring(s) at valve connection to riser pipe.

**Water Leaks from Drain Hose** during service:

1. Faulty rotor disc, seal or wave washer.
2. Faulty o-ring on inlet disc shaft.

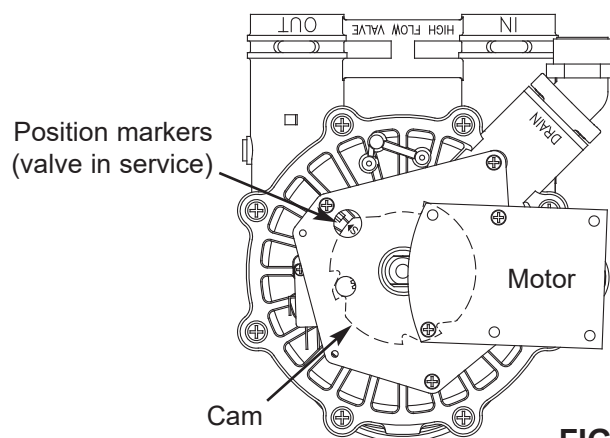
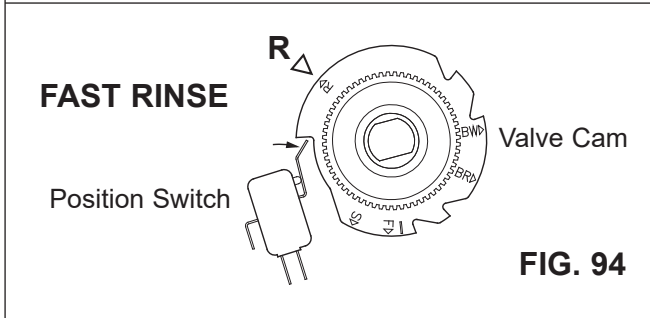
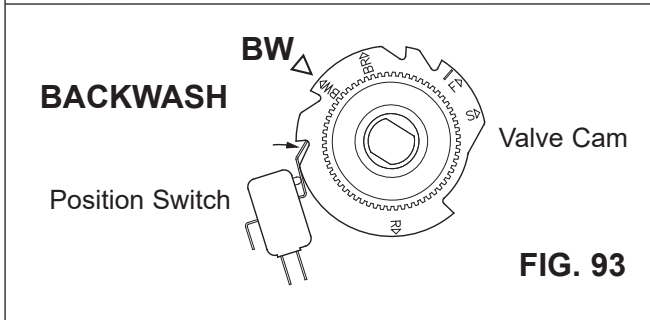
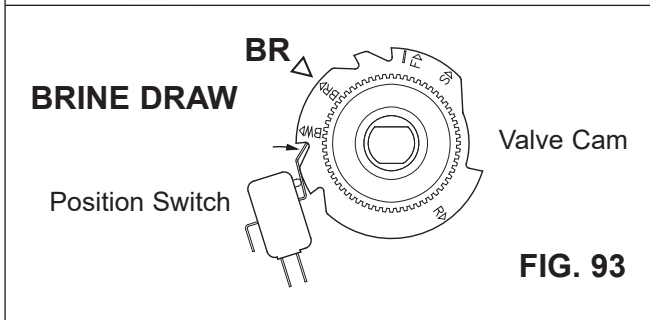
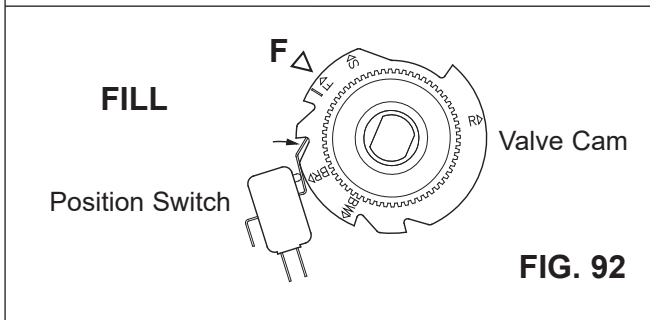
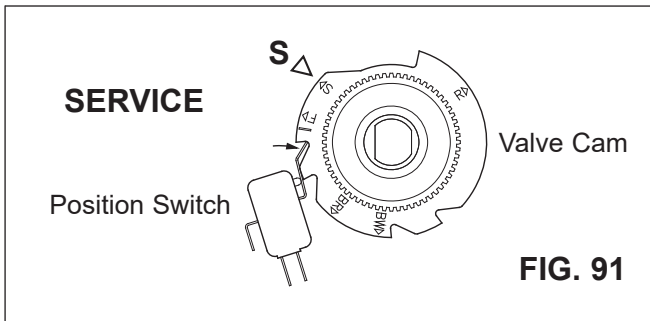
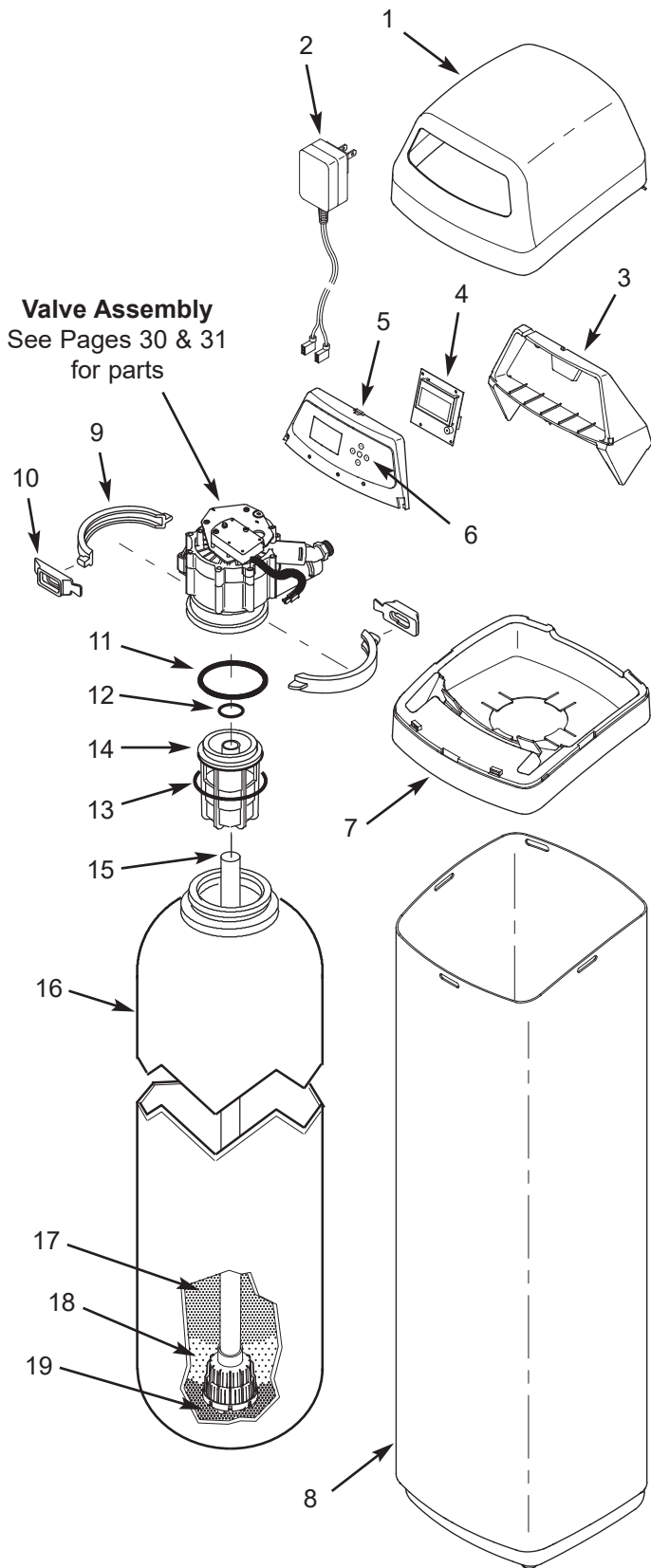

FIG. 90

# Troubleshooting



# Filter Assembly Parts



Key No.	Part No.	Description
1	7371884	Top Cover
2	7351054	Power Supply, 24V DC
3	7291212	Support, Faceplate
-	7371680	Repl. Faceplate Assembly (includes Key Nos. 4-6)
4	↑	Electronic Controller (PWA)
5	↑	Faceplate
6	↑	Keypad/Decal
7	7371876	Rim
8	7371630	Shroud
-	7331177	Tank Neck Clamp Kit (includes 2 ea. of Key Nos. 9 & 10)
9	↑	Clamp Section (2 req.)
10	↑	Retainer, Clamp (2 req.)
-	7112963	Distributor O-Ring Kit (includes Key Nos. 11-13)
11	↑	O-Ring, 2-7/8" x 3-1/4"
12	↑	O-Ring, 13/16" x 1-1/16"
13	↑	O-Ring, 2-3/4" x 3"
14	7088855	Top Distributor
15	7105047	Repl. Bottom Distributor
16	7113074	Repl. Mineral Tank, 12" x 54"
17	0505647	Filter Aggregate, 1 cu. ft. *
	3423699	Neutralite, 1/2 cu. ft. *
	7336834	Activated Carbon, 1 cu. ft. *
18	0501783	Filter Sand, 10 lbs. *
19	7124415	Gravel, 17 lbs. (unit includes 29 lbs.)

\* Not included with the system.

# Valve Exploded View

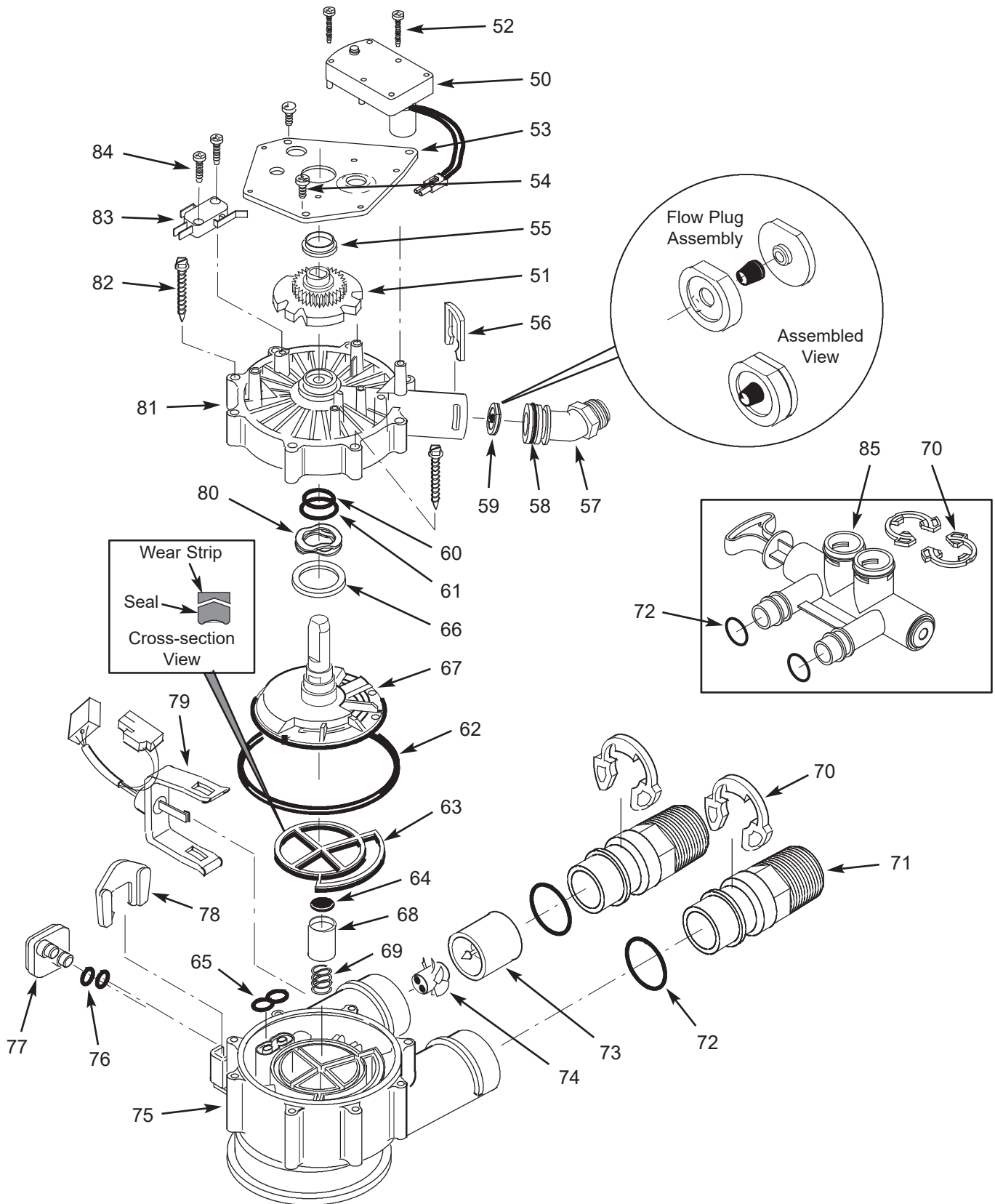

# Valve Parts List

Key No.	Part No.	Description
–	7384691	Motor, Cam & Gear Kit, 1" (includes Key Nos. 50-52)
50	↑	Motor
51	↑	Cam & Gear
52	7224087	Screw, #8-32 x 1" (2 req.)
53	7231393	Motor Plate
54	0900857	Screw, #6-20 x 3/8" (3 req.)
55	7171250	Bearing
56	7169180	Clip, Drain
57	7172793	Drain Hose Adaptor
58	7170288	O-Ring, 15/16" x 1-3/16", single
	7336402	O-Ring, 15/16" x 1-3/16", pack of 20
59	7178202	Flow Plug, 7 gpm (included)
	7178210	Flow Plug, 10 gpm *
	7178189	Flow Plug, 5 gpm *
	7177808	Flow Plug, 3 gpm *
–	7185487	Seal Kit (includes Key Nos. 60-65)
60	↑	O-Ring, 5/8" x 13/16"
61	↑	O-Ring, 1-1/8" x 1-1/2"
62	↑	O-Ring, 4-1/2" x 4-7/8"
63	↑	Rotor Seal
64	↑	Seal
65	↑	Seal, Nozzle & Venturi
66	7174313	Bearing, Wave Washer
67	7185500	Rotor & Disc

Key No.	Part No.	Description
68	7171187	Plug, Drain Seal
69	7129889	Spring
70	7089306	Clip, 1", single (2 req.)
	7336428	Clip, 1", pack of 20
71	7271204	Installation Adaptor, 1", single
	7336614	Installation Adaptor, 1", pack of 10
72	7311127	O-Ring, 1-1/16" x 1-5/16", single (2 req.)
	7336410	O-Ring, 1-1/16" x 1-5/16", pack of 20
–	7290931	Turbine & Support Assembly (includes 1 ea. of Key Nos. 73, 74 & 2 ea. of Key No. 72)
73	↑	Turbine Support & Shaft
74	↑	Turbine
75	7171145	Valve Body
76	7342649	O-Ring, 1/4" x 3/8", pack of 2
77	7100940	Plug
78	7081201	Retainer
79	7309811	Wire Harness, Position Switch
80	7175199	Wave Washer
81	7171161	Valve Cover
82	7342681	Screw, #10 x 2-5/8", pack of 8
83	7305150	Switch
84	7140738	Screw, #4-24 x 3/4" (2 req.)
85	7214383	Bypass Valve, 1" * (includes 2 ea. of Key Nos. 70 & 72)

\* Not included with the system.

# LIMITED WARRANTY

## Model IDP12F Multipurpose Water Filter

**Warrantor: Water Channel Partners, 2805 Dodd Road, Suite 300, Eagan, MN 55121**

Warrantor guarantees to the original purchaser when the product is purchased from an authorized dealer, and when installed and maintained in accordance with the instructions, that:

for the LIFETIME of the original purchaser when the product is purchased from an authorized dealer, the MINERAL TANK will not rust, corrode, leak, burst, or in any other manner fail to perform in accordance with its written specifications, and that,

for a period of THREE (3) YEARS from the date the product is delivered, the VALVE BODY, ELECTRONIC FACEPLATE and ALL OTHER PARTS will be free of defects in materials and workmanship and will perform in accordance with their written specifications.

If, during the respective warranty period, a part proves, after inspection by Warrantor, to be defective, Warrantor will, at its sole option repair or replace that part at no charge, other than normal shipping, installation or service charges.

### General Provisions

The above warranties are effective provided the water filter is operated at water pressures not exceeding 100 psi, and at water temperatures not exceeding 120°F; provided further that the water filter is not subject to abuse, misuse, alteration, neglect, freezing, accident or negligence; and provided further that the water filter is not damaged as the result of any force of nature such as, but not limited to, flood, hurricane, tornado or earthquake.

The limited warranty does not cover damage due to: (a) transportation, (b) storage, (c) improper use, (d) failure to follow the product instructions or to perform any preventive maintenance, (e) modifications, (f) unauthorized repair, (g) normal wear and tear, or (h) external causes such as accidents, abuse, or other actions or events beyond Warrantor's reasonable control. Use of aftermarket, used, or non-manufacturer provided parts will void all warranties. Warranty does not cover failures due to improper product installation. Warrantor is excused if failure to perform its warranty obligations is the result of strikes, government regulation, materials shortages, or other circumstances beyond its control.

To obtain warranty service, notice must be given, within thirty (30) days of the discovery of the defect, to your local dealer or representative.

THERE ARE NO WARRANTIES ON THE WATER FILTER BEYOND THOSE SPECIFICALLY DESCRIBED ABOVE. ALL IMPLIED WARRANTIES, INCLUDING ANY IMPLIED WARRANTY OF MERCHANTABILITY OR OF FITNESS FOR A PARTICULAR PURPOSE, ARE DISCLAIMED TO THE EXTENT THEY MIGHT EXTEND BEYOND THE ABOVE PERIODS. THE SOLE OBLIGATION OF WARRANTOR UNDER THESE WARRANTIES IS TO REPLACE OR REPAIR THE COMPONENT OR PART WHICH PROVES TO BE DEFECTIVE WITHIN THE SPECIFIED TIME PERIOD, AND WARRANTOR IS NOT LIABLE FOR CONSEQUENTIAL OR INCIDENTAL DAMAGES. NO DEALER, AGENT, REPRESENTATIVE, OR OTHER PERSON IS AUTHORIZED TO EXTEND OR EXPAND THE WARRANTIES EXPRESSLY DESCRIBED ABOVE.

Some states do not allow the exclusion or limitation of incidental or consequential damages, so the above limitation or exclusion may not apply to you. This warranty gives you specific legal rights, and you may have other rights which vary from state to state. This warranty applies to consumer-owned installations only.